

HYDRAULIC HOSE & FITTINGS



// INDEX



// HOSE.....	7
// FERRULE SELECTION CHART.....	34
// STANDARD FITTINGS.....	38
// NEW POWERTRAK FITTINGS.....	92
// WATERBLAST FITTINGS.....	107
// INTERLOCK FITTINGS.....	111
// BSP ADAPTERS.....	129
// JIC 37° ADAPTERS.....	152
// ORFS ADAPTERS.....	190
// DIN 24° ADAPTERS.....	216
// PRESSURE WASH ADAPTERS.....	287
// HYDRAULIC QUICK COUPLINGS.....	290
// CLAMPS.....	323
// PIPES.....	341
// ACCESSORIES.....	348
// MACHINES AND TOOLS.....	378
// APPENDIX.....	396
// INDEX.....	426

// ICONS



Det Norske Veritas
Germanischer Lloyd



Halogen free



High Temperature
resistance



Lloyd's Register
approved



U.S. Mine Safety and
Health Administration
approved





Low Temperature
resistance

THE SAFE SOLUTION FOR WATERBLASTING APPLICATION



WATERBLAST

MAIN APPLICATION

-  SURFACE PREPARATION AND CLEANING
-  HYDRODEMOLITION
-  WATER JET CUTTING

 **DUNLOP HIFLEX**



// HOSE

// TEXTILE BRAID.....	8	// LOW TEMPERATURE.....	19
// WIRE BRAID.....	9	// OIL RETURN LINES.....	20
// WIRE SPIRAL - POWERFLEXBIO.....	15	// PRESSURE WASH.....	22
// TUFLEX.....	17	// THERMOPLASTIC.....	25
// HIGH TEMPERATURE.....	18	// PTFE.....	32

// TEXTILE BRAID

// ARGUS 2TE

**EN 854 2TE****Tube:** oil resistant synthetic rubber.**Reinforcement:** one high tensile textile braid.**Cover:** abrasion, ozone and hydrocarbon resistant synthetic rubber.**Application:** medium pressure hydraulic lines, fuel oil, antifreeze solutions, air and water.**Temperature:** -40 °C +100 °C (-40 °F +212 °F)
air max T = +70 °C (+160 °F)**Length:** random**DH SCAN crimp short code:** 2TE

Item Code	ID (Dash)	ID (mm)	ID (in)	OD (mm)	OD (in)	WP (Mpa)	WP (psi)	BP (Mpa)	BP (psi)	BR (mm)	BR (in)	Weight (kg/m)	Weight (lb/ft)
1001398	4	6,0	1/4"	13,1	0,52	7,5	1100	30,0	4300	40	1,57	0,112	0,08
1001399	5	8,0	5/16"	14,9	0,59	6,8	986	27,0	3945	50	1,97	0,148	0,10
1001400	6	10,0	3/8"	16,5	0,65	6,3	920	25,2	3680	60	2,36	0,163	0,11
1001401	8	13,0	1/2"	19,7	0,78	5,8	840	23,2	3360	70	2,76	0,216	0,15
1001402	10	16,0	5/8"	23,9	0,94	5,0	730	20,0	2900	90	3,54	0,281	0,19
1001761	12	19,0	3/4"	27,0	1,06	4,5	650	18,0	2610	110	4,33	0,350	0,24
1001404	16	25,0	1"	34,4	1,35	4,0	600	16,0	2320	150	5,91	0,497	0,34

// 2TE RAILWAY

**EN 854 2TE - EN 45545-2****Tube:** oil resistant synthetic rubber.**Reinforcement:** one high tensile textile braid.**Cover:** abrasion, ozone and hydrocarbon resistant synthetic rubber.**Application:** medium pressure hydraulic lines, fuel oil, antifreeze solutions, air and water.

Specially designed for railway applications.

Temperature: -40 °C +100 °C (-40 °F +212 °F)
air max T = +70 °C (+160 °F)**Length:** random

Item Code	ID (Dash)	ID (mm)	ID (in)	OD (mm)	OD (in)	WP (Mpa)	WP (psi)	BP (Mpa)	BP (psi)	BR (mm)	BR (in)	Weight (kg/m)	Weight (lb/ft)
1002681	5	8,0	5/16"	14,9	0,59	6,8	986	27,0	3945	50	1,97	0,148	0,10
1002682	6	10,0	3/8"	16,5	0,65	6,3	920	25,2	3680	60	2,36	0,163	0,11
1002683	8	13,0	1/2"	19,7	0,78	5,8	840	23,2	3360	70	2,76	0,206	0,14
1002684	10	16,0	5/8"	23,9	0,94	5,0	730	20,0	2900	90	3,54	0,281	0,19
1002685	12	19,0	3/4"	27,0	1,06	4,5	650	18,0	2610	110	4,33	0,350	0,24
1002686	16	25,0	1"	34,4	1,35	4,0	600	16,0	2320	150	5,91	0,497	0,34

REV.2.1

// WIRE BRAID

// 121T SLIMLINE PLUS - 1SC

**EN 857 1SC - ISO 11237****Tube:** oil resistant synthetic rubber.**Reinforcement:** one high tensile steel braid.**Cover:** abrasion, ozone and hydrocarbon resistant synthetic rubber.**Application:** high pressure hydraulic lines, fuel oil, antifreeze solutions, air and water.**Temperature:** -40 °C +100 °C (-40 °F +212 °F)
air max T = +70 °C (+160 °F)**Length:** random**DH SCAN crimp short code:** 121B

Item Code	ID (Dash)	ID (mm)	ID (in)	OD (mm)	OD (in)	WP (Mpa)	WP (psi)	BP (Mpa)	BP (psi)	BR (mm)	BR (in)	Weight (kg/m)	Weight (lb/ft)
1000944	4	6,0	1/4"	12,1	0,48	22,5	3250	90,0	13000	50	1,97	0,170	0,12
1000948	6	10,0	3/8"	15,6	0,61	21,0	3000	84,0	12000	65	2,56	0,260	0,18
1000950	8	13,0	1/2"	19,5	0,77	16,0	2320	64,0	9280	90	3,54	0,410	0,28
1000952	10	16,0	5/8"	23,0	0,91	13,0	1900	52,0	7560	100	3,94	0,440	0,30
1000954	12	19,0	3/4"	26,7	1,05	10,5	1530	42,0	6000	125	4,92	0,570	0,39
1000956	16	25,0	1"	34,9	1,37	8,8	1280	35,2	5100	150	5,91	0,740	0,50

// 141T SUPERSLIMLINE

**Tube:** oil resistant synthetic rubber.**Reinforcement:** one high tensile steel braid.**Cover:** abrasion, ozone and hydrocarbon resistant synthetic rubber.**Application:** high pressure hydraulic lines, fuel oil, antifreeze solutions, air and water.**Temperature:** -40 °C +100 °C (-40 °F +212 °F)
air max T = +70 °C (+160 °F)**Length:** random**DH SCAN crimp short code:** 141T

Item Code	ID (Dash)	ID (mm)	ID (in)	OD (mm)	OD (in)	WP (Mpa)	WP (psi)	BP (Mpa)	BP (psi)	BR (mm)	BR (in)	Weight (kg/m)	Weight (lb/ft)
1001212	4	6,0	1/4"	12,0	0,47	28,0	4000	112,0	16000	80	3,15	0,170	0,12
1001112	6	10,0	3/8"	15,4	0,61	22,5	3250	90,0	13000	105	4,13	0,260	0,18
1001778	8	13,0	1/2"	19,2	0,76	21,0	3000	84,0	12000	120	4,72	0,360	0,25

// 122T GREENLINE PLUS - 1SN/R1AT



SAE 100 R1AT - ISO 1436-1 - UNI EN 853 1SN

Tube: oil resistant synthetic rubber.

Reinforcement: one high tensile steel braid.

Cover: smooth up to 1", wrapped over 1". Abrasion, ozone and hydrocarbon resistant synthetic rubber.

Application: high pressure hydraulic lines, fuel oil, antifreeze solutions, air and water.

Temperature: -40 °C +100 °C (-40 °F +212 °F)

air max T = +70 °C (+160 °F)

Length: random up to 1" - 61 m max over 1 1/4"

DH SCAN crimp short code: 122T

Item Code	ID (Dash)	ID (mm)	ID (in)	OD (mm)	OD (in)	WP (Mpa)	WP (psi)	BP (Mpa)	BP (psi)	BR (mm)	BR (in)	Weight (kg/m)	Weight (lb/ft)
1002584	3	5,0	3/16"	11,1	0,44	25,0	3630	100,0	14500	90	3,54	0,160	0,11
1002755	4	6,0	1/4"	13,0	0,51	22,5	3250	90,0	13000	100	3,94	0,198	0,14
1003033	5	8,0	5/16"	14,5	0,57	21,5	3120	86,0	12500	115	4,53	0,236	0,16
1002756	6	10,0	3/8"	17,2	0,68	18,0	2610	72,0	10500	130	5,12	0,313	0,22
1002758	8	13,0	1/2"	20,1	0,79	16,0	2320	64,0	9280	180	7,09	0,367	0,25
1002760	10	16,0	5/8"	23,1	0,91	13,0	1900	52,0	7560	200	7,87	0,466	0,32
1002761	12	19,0	3/4"	27,3	1,07	10,5	1530	42,0	6000	240	9,45	0,555	0,38
1002763	16	25,0	1"	35,2	1,39	8,8	1280	35,2	5100	300	11,81	0,950	0,64
1002765	20	32,0	1 1/4"	42,1	1,66	6,3	920	25,2	3680	420	16,54	1,095	0,74
1001371	24	38,0	1 1/2"	49,2	1,94	5,0	730	20,0	2900	500	19,69	1,411	0,95
1001372	32	51,0	2"	62,4	2,46	4,0	600	16,0	2320	630	24,80	1,864	1,26

// 221T SLIMLINE PLUS - 2SC



EN 857 2SC - ISO 11237

Tube: oil resistant synthetic rubber.

Reinforcement: two high tensile steel braids.

Cover: abrasion, ozone and hydrocarbon resistant synthetic rubber.

Application: high pressure hydraulic lines, fuel oil, antifreeze solutions, air and water.

Temperature: -40 °C +100 °C (-40 °F +212 °F)

air max T = +70 °C (+160 °F)

Length: random on Reel Pack.

DH SCAN crimp short code: 221T

Item Code	ID (Dash)	ID (mm)	ID (in)	OD (mm)	OD (in)	WP (Mpa)	WP (psi)	BP (Mpa)	BP (psi)	BR (mm)	BR (in)	Weight (kg/m)	Weight (lb/ft)
1001006	4	6,0	1/4"	13,2	0,52	40,0	5850	160,0	23200	50	1,97	0,255	0,18
1001011	6	10,0	3/8"	17,0	0,67	33,0	4800	132,0	19200	65	2,56	0,370	0,25
1001015	8	13,0	1/2"	20,3	0,80	27,5	4000	110,0	16000	90	3,54	0,470	0,32
1001017	10	16,0	5/8"	23,9	0,94	25,0	3630	100,0	14500	100	3,94	0,591	0,40
1001020	12	19,0	3/4"	27,9	1,10	21,5	3120	86,0	12500	120	4,72	0,760	0,52
1001022	16	25,0	1"	34,6	1,36	16,5	2400	66,0	9600	150	5,91	1,130	0,76

REV.2.1

// 241T SUPERSLIMLINE - HI-TUFF



MSHA

EN 857 2SC (up to 1") - ISO 11237 - SAE 100 R16

Tube: oil resistant synthetic rubber.**Reinforcement:** two high tensile steel braids.**Cover:** smooth up to 1", wrapped over 1". Abrasion, ozone and hydrocarbon resistant synthetic rubber.**Application:** high pressure hydraulic lines, fuel oil, antifreeze solutions, air and water.**Temperature:** -40 °C +100 °C (-40 °F +212 °F)

air max T = +70 °C (+160 °F)

Length: random up to 1" - 61 m max over 1"1/4**DH SCAN crimp short code:** 241T

Item Code	ID (Dash)	ID (mm)	ID (in)	OD (mm)	OD (in)	WP (Mpa)	WP (psi)	BP (Mpa)	BP (psi)	BR (mm)	BR (in)	Weight (kg/m)	Weight (lb/ft)
1001049	4	6,0	1/4"	13,2	0,52	42,0	6000	168,0	24000	50	1,97	0,259	0,18
1001053	5	8,0	5/16"	14,8	0,58	37,5	5500	150,0	22000	55	2,17	0,313	0,22
1001056	6	10,0	3/8"	17,4	0,69	35,0	5000	140,0	20000	65	2,56	0,382	0,26
1001060	8	13,0	1/2"	20,7	0,81	31,0	4500	124,0	18000	90	3,54	0,502	0,34
1001065	10	16,0	5/8"	23,7	0,93	28,0	4000	112,0	16000	100	3,94	0,598	0,41
1001068	12	19,0	3/4"	27,9	1,10	24,0	3500	96,0	14000	120	4,72	0,821	0,56
1001073	16	25,0	1"	35,6	1,40	21,0	3000	84,0	12000	150	5,91	1,266	0,86
1001791	20	32,0	1 1/4"	42,2	1,66	14,0	2000	58,0	8400	210	8,27	1,367	0,92
1001792	24	38,0	1 1/2"	49,9	1,96	12,5	1820	50,0	7280	430	16,93	1,864	1,26
1001612	32	51,0	2"	63,0	2,48	10,0	1500	40,0	5850	550	21,65	2,462	1,66
1002291	40	63,0	2 1/2"	76,4	3,01	7,5	1100	30,0	4300	720	28,35	3,300	2,22
1002292	48	76,0	3"	90,0	3,54	7,0	1000	28,0	4000	880	34,65	3,850	2,59

// 241T-R SUPERSLIMLINE - HI-TUFF



MSHA

EN 857 2SC (up to 1") - ISO 11237 - SAE 100 R16

Tube: oil resistant synthetic rubber.**Reinforcement:** two high tensile steel braids.**Cover:** smooth up to 1", wrapped over 1". Abrasion, ozone and hydrocarbon resistant synthetic rubber.**Application:** high pressure hydraulic lines, fuel oil, antifreeze solutions, air and water.**Temperature:** -40 °C +100 °C (-40 °F +212 °F)

air max T = +70 °C (+160 °F)

Length: random up to 1" - 61 m max over 1"1/4**DH SCAN crimp short code:** FXP2-R

Item Code	ID (Dash)	ID (mm)	ID (in)	OD (mm)	OD (in)	WP (Mpa)	WP (psi)	BP (Mpa)	BP (psi)	BR (mm)	BR (in)	Weight (kg/m)	Weight (lb/ft)
1003111	8	13,0	1/2"	21,0	0,83	35,0	5000	140,0	20000	120	4,72	0,534	0,36
1004915	10	16,0	5/8"	24,0	0,94	35,0	5000	140,0	20000	135	5,31	0,686	0,47
1001721	12	19,0	3/4"	50,0	1,97	28,0	4000	112,0	16000	150	5,91	0,831	0,56
1004362	16	25,0	1"	35,6	1,40	25,0	3630	100,0	14500	152	5,98	1,359	0,92

// 222T GREENLINE PLUS - 2SN/R2AT



SAE 100 R2AT - ISO 1436-1 - UNI EN 853 2SN

Tube: oil resistant synthetic rubber.

Reinforcement: two high tensile steel braids.

Cover: smooth up to 1", wrapped over 1". Abrasion, ozone and hydrocarbon resistant synthetic rubber.

Application: high pressure hydraulic lines, fuel oil, antifreeze solutions, air and water.

Temperature: -40 °C +100 °C (-40 °F +212 °F)
air max T = +70 °C (+160 °F)

Length: random up to 1" - 61 m max over 1 1/4"

DH SCAN crimp short code: 222T

Item Code	ID (Dash)	ID (mm)	ID (in)	OD (mm)	OD (in)	WP (Mpa)	WP (psi)	BP (Mpa)	BP (psi)	BR (mm)	BR (in)	Weight (kg/m)	Weight (lb/ft)
1002769	4	6,0	1/4"	14,5	0,57	40,0	5850	160,0	23200	100	3,94	0,330	0,23
1002770	5	8,0	5/16"	16,1	0,63	35,0	5000	140,0	20000	115	4,53	0,357	0,24
1002773	6	10,0	3/8"	18,5	0,73	33,0	4800	132,0	19200	125	4,92	0,463	0,32
1002776	8	13,0	1/2"	21,4	0,84	27,5	4000	110,0	16000	175	6,89	0,534	0,36
1002778	10	16,0	5/8"	24,6	0,97	25,0	3630	100,0	14500	200	7,87	0,665	0,45
1002780	12	19,0	3/4"	29,0	1,14	21,5	3120	86,0	12500	240	9,45	0,895	0,61
1002782	16	25,0	1"	36,8	1,45	16,5	2400	66,0	9600	300	11,81	1,253	0,85
1002783	20	32,0	1 1/4"	46,4	1,83	12,5	1820	50,0	7280	420	16,54	1,852	1,25
1001382	24	38,0	1 1/2"	52,8	2,08	9,0	1310	36,0	5240	500	19,69	2,086	1,41
1001383	32	51,0	2"	65,6	2,58	8,0	1200	32,0	4640	630	24,80	2,748	1,85

// SP33G SUPERFOREST



Tube: oil resistant synthetic rubber.

Reinforcement: three high tensile steel braids.

Cover: smooth up to 1", wrapped over 1". Abrasion, ozone and hydrocarbon resistant synthetic rubber.

Application: high pressure hydraulic lines, fuel oil, antifreeze solutions, air and water.

Temperature: -40 °C +100 °C (-40 °F +212 °F)
air max T = +70 °C (+160 °F)

Length: random

DH SCAN crimp short code: 33G

Item Code	ID (Dash)	ID (mm)	ID (in)	OD (mm)	OD (in)	WP (Mpa)	WP (psi)	BP (Mpa)	BP (psi)	BR (mm)	BR (in)	Weight (kg/m)	Weight (lb/ft)
1001037	6	10,0	3/8"	21,1	0,83	50,0	7280	196,0	28000	120	4,72	0,730	0,50
1001038	8	13,0	1/2"	24,1	0,95	46,9	6800	188,0	27200	160	6,30	0,863	0,58
1001039	10	16,0	5/8"	27,8	1,09	41,0	6000	164,0	23500	210	8,27	1,084	0,73
1001040	12	19,0	3/4"	32,2	1,27	37,5	5500	150,0	22000	260	10,24	1,380	0,93
1001041	16	25,0	1"	39,2	1,54	32,7	4750	130,8	19000	310	12,20	1,882	1,27
1001042	20	32,0	1 1/4"	45,9	1,81	24,0	3500	96,0	14000	410	16,14	2,310	1,56

HI-TUFF

HIGH ABRASION

RESISTANCE

HI-TUFF

- ▶ **Excellent abrasion resistance**
(10 times higher than EN-ISO 6945 requirement)
- ▶ **High ozone resistance**
(10 times more than the standard)
- ▶ **MSHA approved cover**
- ▶ **Alternative to protective sleeve in applications requiring abrasion resistance**

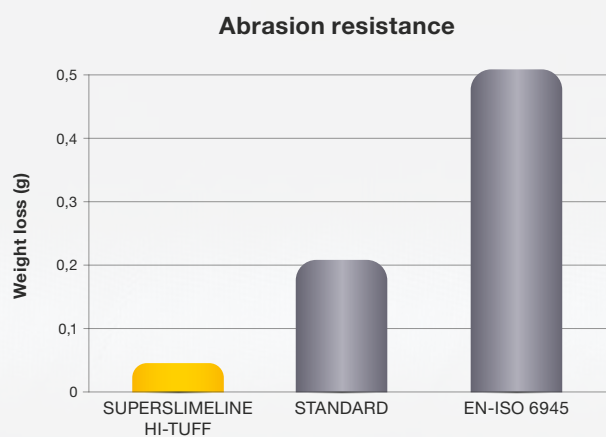

EXTRA FLEXIBLE
BIO OIL RESISTANT
HOSE RANGE



POWERFLEX^{Bio}

- **Specially designed for bio oil full compability**
- **Extreme flexibility:** up to 50% better bend radius compared to SAE 100R
- **Minetuff cover for top abrasion & ozone resistance**
- **MSHA-approved fire resistant cover**

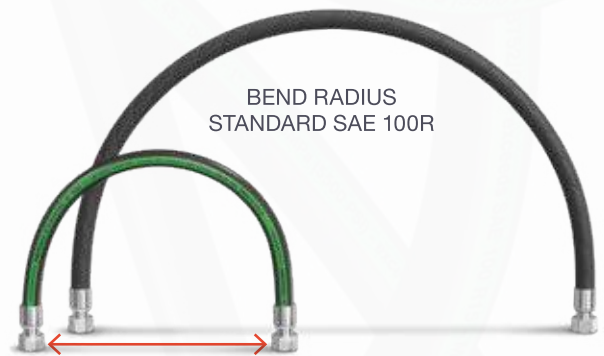

BEND RADIUS
STANDARD SAE 100R

BEND RADIUS: REDUCED UP TO 50%

// WIRE SPIRAL - POWERFLEXBIO

// POWERFLEXBIO 4000 - HI-TUFF



MSHA

ISO 18752

Tube: oil resistant synthetic rubber and biodegradable hydraulic fluids.

Reinforcement: four high tensile steel spirals.

Cover: smooth up to 1", wrapped over 1". Abrasion, ozone and hydrocarbon resistant synthetic rubber.

Application: developed to withstand very demanding conditions, very high performance in pressure, pulsing and flexing.

Temperature: -40 °C +121 °C (-40 °F +250 °F)

Length: random up to 1" - 61 m max over 1"1/4

DH SCAN crimp short code: PFB40

Item Code	Constr.	ID (Dash)	ID (in)	ID (mm)	OD (mm)	OD (in)	WP (Mpa)	WP (psi)	BP (Mpa)	BP (psi)	BR (mm)	BR (in)	Weight (kg/m)	Weight (lb/ft)
1001743	4WS	12	3/4"	19,0	29,5	1,16	28,0	4000	112,0	16000	120	4,72	1,019	0,69
1001744	4WS	16	1"	25,0	37,5	1,48	28,0	4000	112,0	16000	150	5,91	1,556	1,05
1002799	4WS	24	1 1/2"	38,0	51,8	2,04	29,0	4200	116,0	16800	420	16,54	2,907	1,96
1002491	4WS	32	2"	51,0	67,6	2,66	28,0	4000	112,0	16000	630	24,80	4,383	2,95

// POWERFLEXBIO 5000 - HI-TUFF

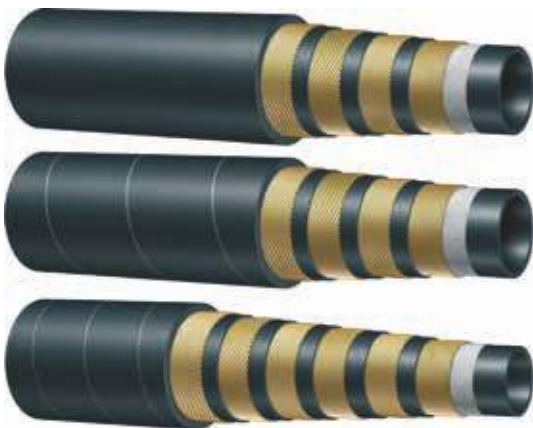

MSHA

ISO 18752

Tube: oil resistant synthetic rubber and biodegradable hydraulic fluids.

Reinforcement: four/six high tensile steel spirals.

Cover: smooth up to 1", wrapped over 1". Abrasion, ozone and hydrocarbon resistant synthetic rubber.

Application: developed to withstand very demanding conditions, very high performance in pressure, pulsing and flexing.

Temperature: -40 °C +121 °C (-40 °F +250 °F)

Length: random up to 1" - 61 m max over 1"1/4

DH SCAN crimp short code: 4WS: PFB50 / 6WS: PFB50-6S

Item Code	Constr.	ID (Dash)	ID (in)	ID (mm)	OD (mm)	OD (in)	WP (Mpa)	WP (psi)	BP (Mpa)	BP (psi)	BR (mm)	BR (in)	Weight (kg/m)	Weight (lb/ft)
1001745	4WS	10	5/8"	16,0	25,9	1,02	35,0	5000	140,0	20000	140	5,51	0,927	0,63
1001746	4WS	12	3/4"	19,0	31,0	1,22	35,0	5000	140,0	20000	150	5,91	1,228	0,83
1001747	4WS	16	1"	25,0	38,0	1,50	35,0	5000	140,0	20000	180	7,09	1,710	1,15
1001748	4WS	20	1 1/4"	32,0	45,8	1,80	35,0	5000	140,0	20000	280	11,02	2,463	1,66
1001946	6WS	24	1 1/2"	38,0	54,8	2,16	35,0	5000	140,0	20000	500	19,69	3,924	2,64
1001947	6WS	32	2"	51,0	70,2	2,76	35,0	5000	140,0	20000	550	21,65	6,174	4,15

// POWERFLEXBIO 5000 PLUS - HI-TUFF



ISO 18752

Tube: oil resistant synthetic rubber and biodegradable hydraulic fluids.

Reinforcement: four high tensile steel spirals.

Cover: abrasion, ozone and hydrocarbon resistant synthetic rubber.

Application: developed to withstand very demanding conditions, very high performance in pressure, pulsing and flexing.

Temperature: -40 °C +121 °C (-40 °F +250 °F)

Length: random

DH SCAN crimp short code: PFB55

Item Code	ID (Dash)	ID (mm)	ID (in)	OD (mm)	OD (in)	WP (Mpa)	WP (psi)	BP (Mpa)	BP (psi)	BR (mm)	BR (in)	Weight (kg/m)	Weight (lb/ft)
1001749	12	19,0	3/4"	31,4	1,24	38,0	5500	152,0	22040	180	7,09	1,266	0,86
1001734	16	25,0	1"	38,0	1,50	38,0	5500	152,0	22040	210	8,27	1,918	1,29

// POWERFLEXBIO 6000 - HI-TUFF

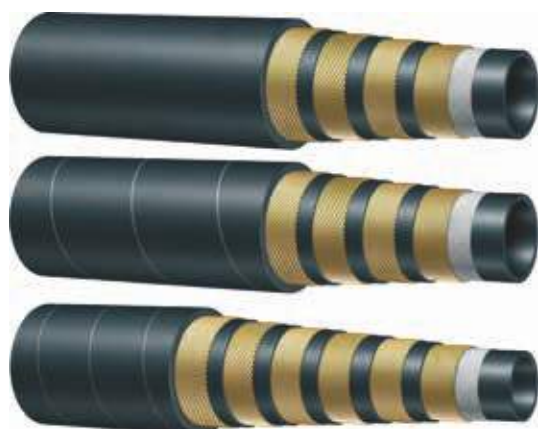

ISO 18752 - exceeds SAE 100 R15

Tube: oil resistant synthetic rubber and biodegradable hydraulic fluids.

Reinforcement: four/six high tensile steel spirals.

Cover: smooth up to 1", wrapped over 1". Abrasion, ozone and hydrocarbon resistant synthetic rubber.

Application: developed to withstand very demanding conditions, very high performance in pressure, pulsing and flexing.

Temperature: -40 °C +121 °C (-40 °F +250 °F)

Length: random up to 1" - 61 m max over 1"1/4

DH SCAN crimp short code: up to 1": PFB60 / 1 1/4" 4WS: PFB60-4S / 6WS: PFB60-6S

Item Code	Constr.	ID (Dash)	ID (in)	ID (mm)	OD (mm)	OD (in)	WP (Mpa)	WP (psi)	BP (Mpa)	BP (psi)	BR (mm)	BR (in)	Weight (kg/m)	Weight (lb/ft)
1001751	4WS	4	1/4"	6,0	17,3	0,68	45,0	6550	180,0	26200	60	2,36	0,518	0,35
1001752	4WS	6	3/8"	10,0	19,9	0,78	44,5	6450	178,0	25800	75	2,95	0,630	0,43
1001735	4WS	8	1/2"	13,0	23,0	0,91	42,0	6000	168,0	24000	90	3,54	0,745	0,51
1001736	4WS	10	5/8"	16,0	28,2	1,11	42,0	6000	168,0	24000	180	7,09	1,260	0,85
1001737	4WS	12	3/4"	19,0	31,4	1,24	42,0	6000	168,0	24000	210	8,27	1,417	0,96
1001738	4WS	16	1"	25,0	38,6	1,52	42,0	6000	168,0	24000	250	9,84	1,991	1,34
1002492	4WS	20	1 1/4"	32,0	46,1	1,81	42,0	6000	168,0	24000	445	17,52	2,859	1,93
1002493	6WS	20	1 1/4"	32,0	49,4	1,94	42,0	6000	168,0	24000	445	17,52	3,415	2,30
1002494	6WS	24	1 1/2"	38,0	56,5	2,22	42,0	6000	168,0	24000	530	20,87	4,476	3,01
1003506	6WS	32	2"	51,0	71,0	2,80	42,0	6000	168,0	24000	650	25,59	6,398	4,30

Item Code 1002492: to be assembled with Interlock fittings (H14...) only.

// TUFLEX

// 241X SUPERSLIMLINE - TUFLEX



MSHA

EN 857 2SC - ISO 11237 - SAE 100 R16

Tube: oil resistant synthetic rubber.**Reinforcement:** two high tensile steel braids.**Cover:** abrasion, ozone and hydrocarbon resistant synthetic rubber. Special "tuflex" cover for excellent abrasion resistance and long service life in heavy duty applications.**Application:** high pressure hydraulic lines, fuel oil, antifreeze solutions, air and water.**Temperature:** -40 °C +100 °C (-40 °F +212 °F)
air max T = +70 °C (+160 °F)**Length:** random**DH SCAN crimp short code:** 241X

Item Code	ID (Dash)	ID (mm)	ID (in)	OD (mm)	OD (in)	WP (Mpa)	WP (psi)	BP (Mpa)	BP (psi)	BR (mm)	BR (in)	Weight (kg/m)	Weight (lb/ft)
1001077	4	6,0	1/4"	13,2	0,52	45,0	6550	180,0	26200	50	1,97	0,275	0,19
1001079	6	10,0	3/8"	17,4	0,69	35,0	5000	140,0	20000	65	2,56	0,393	0,27
1001081	8	13,0	1/2"	20,6	0,81	31,0	4500	124,0	18000	90	3,54	0,528	0,36
1001082	10	16,0	5/8"	23,7	0,93	28,0	4000	112,0	16000	100	3,94	0,622	0,42
1001083	12	19,0	3/4"	27,7	1,09	28,0	4000	112,0	16000	120	4,72	0,830	0,56
1001084	16	25,0	1"	35,6	1,40	21,0	3000	84,0	12000	150	5,91	1,300	0,88

// POWERFLEXBIO 4000 - TUFLEX



MSHA

EN 18752

Tube: oil resistant synthetic rubber and biodegradable hydraulic fluids.**Reinforcement:** four high tensile steel spirals.**Cover:** abrasion, ozone and hydrocarbon resistant synthetic rubber. Special "tuflex" cover for excellent abrasion resistance and long service life in heavy duty applications.**Application:** developed to withstand very demanding conditions, very high performance in pressure, pulsing and flexing.**Temperature:** -40 °C +121 °C (-40 °F +250 °F)**Length:** 61m**DH SCAN crimp short code:** PFBT40

Item Code	ID (Dash)	ID (mm)	ID (in)	OD (mm)	OD (in)	WP (Mpa)	WP (psi)	BP (Mpa)	BP (psi)	BR (mm)	BR (in)	Weight (kg/m)	Weight (lb/ft)
1003701	24	38,0	1 1/2"	51,8	2,04	29,0	4200	116,0	16800	420	16,54	2,981	2,01
1003703	32	51,0	2"	67,6	2,66	28,0	4000	112,0	16000	630	24,80	4,540	3,06

// HIGH TEMPERATURE

// COMMANDER 150 1SN PLUS **NEW**



SAE 100 R1AT - ISO 1436-1 - UNI EN 853 1SN

Tube: oil resistant synthetic rubber.

Reinforcement: one high tensile steel braid.

Cover: smooth up to 1", wrapped over 1". Blue abrasion, ozone and hydrocarbon resistant synthetic rubber.

Application: high pressure hydraulic lines, fuel oil, antifreeze solutions, air and water.

Specially designed for high temperature applications.

Not recommended for steam service.

Temperature: -40 °C +150 °C (-40 °F +300 °F)

air max T up to 5/8" = +85 °C (+185 °F)

air max T over 3/4" = +110 °C (+230 °F)

Length: random up to 5/8" - 61 m max over 3/4"

DH SCAN crimp short code: 150PLUS-1SN

Item Code	ID (Dash)	ID (mm)	ID (in)	OD (mm)	OD (in)	WP (Mpa)	WP (psi)	BP (Mpa)	BP (psi)	BR (mm)	BR (in)	Weight (kg/m)	Weight (lb/ft)
1004656	4	6,0	1/4"	12,7	0,50	22,5	3250	90,0	13000	100	3,94	0,206	0,14
1004657	6	10,0	3/8"	16,6	0,65	18,0	2610	72,0	10500	130	5,12	0,307	0,21
1004658	8	13,0	1/2"	19,7	0,78	16,0	2320	64,0	9280	180	7,09	0,379	0,26
1004659	10	16,0	5/8"	22,7	0,89	13,0	1900	52,0	7560	200	7,87	0,436	0,30
1004660	12	19,0	3/4"	26,9	1,06	10,5	1530	42,0	6000	240	9,45	0,581	0,40
1004661	16	25,0	1"	34,8	1,37	8,8	1280	35,2	5100	300	11,81	0,915	0,62
1004662	20	32,0	1 1/4"	42,1	1,66	6,3	920	25,2	3680	420	16,54	1,121	0,76
1004663	24	38,0	1 1/2"	49,2	1,94	5,0	730	20,0	2900	500	19,69	1,443	0,97
1004664	32	51,0	2"	62,4	2,46	4,0	600	16,0	2320	630	24,80	1,911	1,29

REV.2.1

// LOW TEMPERATURE

// 261E HYPERCOLD SUPERSLIMLINE



Tube: oil resistant ultra low temperature synthetic rubber.

Reinforcement: two high tensile steel braids.

Cover: smooth up to 1", wrapped over 1". Oil, water, ozone and ultra low temperature resistant synthetic rubber.

Application: hydraulic system with petroleum or water/glycol based fluids, fuel, lubricating oils.

Specially designed for ultra low temperature applications.

Temperature: -55 °C +100 °C (-67 °F +212 °F)
air max T = +70 °C (+160 °F)

Length: random

DH SCAN crimp short code: 261E

Item Code	ID (Dash)	ID (mm)	ID (in)	OD (mm)	OD (in)	WP (Mpa)	WP (psi)	BP (Mpa)	BP (psi)	BR (mm)	BR (in)	Weight (kg/m)	Weight (lb/ft)
1001556	4	6,0	1/4"	13,2	0,52	42,0	6000	168,0	24000	50	1,97	0,280	0,19
1002432	5	8,0	5/16"	14,8	0,58	37,5	5500	150,0	22000	55	2,17	0,310	0,21
1001557	6	10,0	3/8"	17,4	0,69	35,0	5000	140,0	20000	65	2,56	0,390	0,27
1001491	8	13,0	1/2"	20,7	0,81	31,0	4500	124,0	18000	90	3,54	0,520	0,35
1001941	10	16,0	5/8"	23,7	0,93	28,0	4000	112,0	16000	100	3,94	0,600	0,41
1001559	12	19,0	3/4"	27,6	1,09	24,0	3500	96,0	14000	120	4,72	0,810	0,55
1001560	16	25,0	1"	35,6	1,40	21,0	3000	84,0	12000	150	5,91	1,220	0,82

// SP33E HYPERCOLD SUPERFOREST



Tube: oil resistant ultra low temperature synthetic rubber.

Reinforcement: three high tensile steel braids.

Cover: oil, water, ozone and ultra low temperature resistant synthetic rubber.

Application: hydraulic system with petroleum or water/glycol based fluids, fuel, lubricating oils.

Specially designed for ultra low temperature applications.

Temperature: -55 °C +100 °C (-67 °F +212 °F)
air max T = +70 °C (+160 °F)

Length: random

DH SCAN crimp short code: SP33E

Item Code	Product Code	ID (Dash)	ID (mm)	ID (in)	OD (mm)	OD (in)	WP (Mpa)	WP (psi)	BP (Mpa)	BP (psi)	BR (mm)	BR (in)	Weight (kg/m)	Weight (lb/ft)
1001093	8Q8AA01200FVB8	8	13,0	1/2"	24,1	0,95	46,9	6800	188,0	27200	160	6,30	0,892	0,60
1002293	8Q8AA01600FVB8	10	16,0	5/8"	27,8	1,09	41,4	6000	164,0	23500	210	8,27	1,121	0,76
1001094	8Q8AA02000FVB8	12	19,0	3/4"	32,2	1,27	37,5	5500	150,0	22000	260	10,24	1,430	0,97
1001095	8Q8AA02500FVB8	16	25,0	1"	39,2	1,54	33,0	4800	130,8	19000	310	12,20	1,940	1,31

// OIL RETURN LINES

// 605AA



MSHA

Fuel-oil S&D 10 bar (150 psi)

ISO 13363/2 A+B - exceeds SAE 100 R4 - SAE J2006/R2

Tube: black conductive NBR.

Reinforcement: high tensile textile cords with embedded steel helix wire.

Cover: black CR - abrasion, ozone, hydrocarbon and flame resistant.

Application: fuel and oil suction and delivery.

Specially designed for tank truck and general industrial applications. Also suitable for marine wet exhaust and bilge pump connection.

Temperature: -30 °C +80 °C (-22 °F +176 °F)

Item Code	Product Code	ID (mm)	ID (in)	OD (mm)	OD (in)	WP (bar)	WP (psi)	BP (bar)	BP (psi)	BR (mm)	BR (in)	Vacuum %	Weight (kg/m)	Weight (lb/ft)	Length (m)	Brand
2001851	605AA019306MD02	19,0	3/4"	30,0	1,18	10	150	30	450	76	2,99	100,00	0,590	0,40	61,000	AG
2001853	605AA025366MD02	25,0	1"	36,0	1,42	10	150	30	450	100	3,94	100,00	0,740	0,50	61,000	AG
2001856	605AA032436MD02	32,0	1 1/4"	43,0	1,69	10	150	30	450	128	5,04	100,00	0,950	0,64	61,000	AG
2001860	605AA038496MD02	38,0	1 1/2"	49,0	1,93	10	150	30	450	152	5,98	100,00	1,100	0,74	61,000	AG
2001862	605AA042536MD0V	42,0	1 5/8"	53,0	2,09	10	150	30	450	168	6,61	100,00	1,210	0,82	30,500	AG
2001863	605AA045566MD0V	45,0	1 3/4"	56,0	2,20	10	150	30	450	180	7,09	100,00	1,280	0,87	30,500	AG
2001865	605AA051626MD0V	51,0	2"	62,0	2,44	10	150	30	450	204	8,03	100,00	1,430	0,97	30,500	AG
2001867	605AA060736MD0V	60,0	2 3/8"	73,0	2,87	10	150	30	450	240	9,45	100,00	2,010	1,36	30,500	AG
2001868	605AA063766MD0V	63,0	2 1/2"	76,0	2,99	10	150	30	450	252	9,92	90,00	2,100	1,42	30,500	AG
2001870	605AA076896MD0V	76,0	3"	89,0	3,50	10	150	30	450	304	11,97	90,00	2,520	1,70	30,500	AG
2001872	605AA090046MD0V	90,0	3 1/2"	104,0	4,09	10	150	30	450	360	14,17	90,00	3,080	2,07	30,500	AG
2001873	605AA102166MD0V	102,0	4"	116,0	4,57	10	150	30	450	408	16,06	90,00	3,440	2,32	30,500	AG

// FLEXOR R4 634



Extra flexible

SAE 100 R4

Tube: oil resistant synthetic rubber.

Reinforcement: high tensile textile cords with embedded steel helix wire.

Cover: abrasion, ozone and hydrocarbon resistant synthetic rubber.

Application: fuel, oil and hydraulic fluids with 50% max aromatic content suction and delivery.

Specially designed for hydraulic oil return lines requiring tight bend radius.

Temperature: -40 °C +100 °C (-40 °F +212 °F)

Item Code	ID (Dash)	ID (mm)	ID (in)	OD (mm)	OD (in)	WP (Mpa)	WP (psi)	BP (Mpa)	BP (psi)	BR (mm)	BR (in)	Weight (kg/m)	Weight (lb/ft)	Length (m)
1001272	12	19,0	3/4"	30,0	1,18	2,1	300	8,4	1200	38	1,50	0,610	0,41	30,500
1001273	16	25,0	1"	36,0	1,42	1,7	250	6,8	986	50	1,97	0,760	0,52	30,500
1001275	20	32,0	1 1/4"	43,0	1,69	1,4	200	5,6	800	64	2,52	0,930	0,63	30,500
1001278	24	38,0	1 1/2"	49,0	1,93	1,0	150	4,0	600	76	2,99	1,080	0,73	30,500
1001280	32	51,0	2"	62,0	2,44	0,7	100	2,8	400	102	4,02	1,400	0,95	30,500
1001282	40	63,0	2 1/2"	76,0	2,99	0,4	60	1,6	240	125	4,92	2,220	1,50	30,500
1001284	48	76,0	3"	89,0	3,50	0,4	60	1,6	240	152	5,98	2,630	1,77	30,500
1001288	64	102,0	4"	116,0	4,57	0,2	30	0,8	120	204	8,03	3,910	2,63	30,500

REV.2.1

// FLEXOR R4 644 HT



MSHA

Extra flexible - High temperature

SAE 100 R4

Tube: oil resistant synthetic rubber.**Reinforcement:** high tensile textile cords with embedded steel helix wire.**Cover:** abrasion, ozone and hydrocarbon resistant synthetic rubber.**Application:** fuel, oil and hydraulic fluids with 50% max aromatic content suction and delivery.

Specially designed for high temperature applications and hydraulic oil return lines requiring tight bend radius.

Temperature: -40 °C +135 °C (-40 °F +275 °F)

Item Code	ID (Dash)	ID (mm)	ID (in)	OD (mm)	OD (in)	WP (Mpa)	WP (psi)	BP (Mpa)	BP (psi)	BR (mm)	BR (in)	Weight (kg/m)	Weight (lb/ft)	Length (m)
1001277	12	19,0	3/4"	30,0	1,18	2,1	300	8,4	1200	38	1,50	0,620	0,42	30,500
1001274	16	25,0	1"	36,0	1,42	1,7	250	6,8	986	50	1,97	0,770	0,52	30,500
1001196	20	32,0	1 1/4"	43,0	1,69	1,4	200	5,6	800	64	2,52	0,950	0,64	30,500
1001279	24	38,0	1 1/2"	49,0	1,93	1,0	150	4,0	600	76	2,99	1,100	0,74	30,500
1001281	32	51,0	2"	62,0	2,44	0,7	100	2,8	400	102	4,02	1,430	0,97	30,500
1001283	40	63,0	2 1/2"	76,0	2,99	0,4	60	1,6	240	126	4,96	2,170	1,46	30,500
1001285	48	76,0	3"	89,0	3,50	0,4	60	1,6	240	152	5,98	2,690	1,81	30,500
1001290	64	102,0	4"	116,0	4,57	0,2	30	0,8	120	204	8,03	3,530	2,38	30,500

// PRESSURE WASH

// ALFAJET 210



Tube: oil, detergents and hot water resistant synthetic rubber.

Reinforcement: one high tensile steel braid.

Cover: abrasion, ozone and hydrocarbon resistant blue synthetic rubber, pin-pricked. Black cover also available.

Application: high pressure power cleaners. Specially designed for hot water applications.

Not recommended for steam service.

Length: random

DH SCAN crimp short code: AJ210

Item Code	ID (Dash)	ID (mm)	ID (in)	OD (mm)	OD (in)	WP (Mpa)	WP (psi)	BP (Mpa)	BP (psi)	BR (mm)	BR (in)	Weight (kg/m)	Weight (lb/ft)
1000192	4	6,0	1/4"	12,1	0,48	21,0	3000	84,0	12000	50	1,97	0,161	0,11
1000185	5	8,0	5/16"	14,1	0,56	21,0	3000	84,0	12000	60	2,36	0,184	0,13
1000098	6	10,0	3/8"	15,6	0,61	21,0	3000	73,0	10588	65	2,56	0,250	0,17
1000166	8	13,0	1/2"	19,5	0,77	21,0	3000	73,0	10588	90	3,54	0,359	0,25

Item codes: blue cover hose.

// ALFAJET 400



Tube: oil, detergents and hot water resistant synthetic rubber.

Reinforcement: two high tensile steel braids.

Cover: abrasion, ozone and hydrocarbon resistant blue synthetic rubber, pin-pricked. Black cover also available.

Application: high pressure power cleaners. Specially designed for hot water applications.

Not recommended for steam service.

Length: random

DH SCAN crimp short code: AJ400

Item Code	ID (Dash)	ID (mm)	ID (in)	OD (mm)	OD (in)	WP (Mpa)	WP (psi)	BP (Mpa)	BP (psi)	BR (mm)	BR (in)	Weight (kg/m)	Weight (lb/ft)
1000221	4	6,0	1/4"	13,2	0,52	40,0	5850	140,0	20000	70	2,76	0,250	0,17
1000936	6	10,0	3/8"	16,7	0,66	40,0	5850	130,0	18900	90	3,54	0,363	0,25
1000218	8	13,0	1/2"	20,1	0,79	40,0	5850	120,0	17450	115	4,53	0,477	0,33

Item codes: blue cover hose.

REV.2.1

// ALFAJET 640



Tube: oil, detergents and hot water resistant synthetic rubber.

Reinforcement: two high tensile steel braids.

Cover: abrasion, ozone and hydrocarbon resistant blue synthetic rubber, non pin-pricked.

Application: very high pressure power cleaners.

Specially designed for hot water applications.

Not recommended for steam service.

Length: random

DH SCAN crimp short code: AJ640

Item Code	ID (Dash)	ID (mm)	ID (in)	OD (mm)	OD (in)	WP (Mpa)	WP (psi)	BP (Mpa)	BP (psi)	BR (mm)	BR (in)	Weight (kg/m)	Weight (lb/ft)
1004710	6	10,0	3/8"	17,0	0,67	64,0	9280	160,0	23200	65	2,56	0,400	0,27

// WATERBLAST - WB10L



Tube: oil and water resistant synthetic rubber.

Reinforcement: four high tensile steel spirals.

Cover: oil, water and ozone resistant synthetic rubber.

Application: very high pressure water jetting.

Temperature: -10 °C +70 °C (14 °F +158 °F)

Length: multiples of lengths shown in below grid.

DH SCAN crimp short code: WB10L

Item Code	ID (Dash)	ID (in)	ID (mm)	OD (mm)	OD (in)	WP (Mpa)	WP (psi)	BP (Mpa)	BP (psi)	BR (mm)	BR (in)	Weight (kg/m)	Weight (lb/ft)	Length (m)
1001089	6	3/8"	10,0	20,6	0,81	70,0	10000	175,0	25000	150	5,91	0,664	0,45	15,250
1003795	8	1/2"	13,0	23,5	0,93	70,0	10000	175,0	25000	200	7,87	0,805	0,55	15,250
1003796	8	1/2"	13,0	23,5	0,93	70,0	10000	175,0	25000	200	7,87	0,805	0,55	20,000
1004044	12	3/4"	19,0	32,2	1,27	70,0	10000	175,0	25000	210	8,27	1,450	0,98	15,250
1004212	12	3/4"	19,0	32,2	1,27	70,0	10000	175,0	25000	210	8,27	1,450	0,98	20,000
1004213	16	1"	25,0	38,7	1,52	70,0	10000	175,0	25000	320	12,60	2,012	1,36	15,250
1004214	16	1"	25,0	38,7	1,52	70,0	10000	175,0	25000	320	12,60	2,012	1,36	20,000

// WATERBLAST - WB15L



Tube: oil and water resistant synthetic rubber.

Reinforcement: four high tensile steel spirals.

Cover: oil, water and ozone resistant synthetic rubber.

Application: very high pressure water jetting.

Temperature: -10 °C +70 °C (14 °F +158 °F)

Length: multiples of lengths shown in below grid.

DH SCAN crimp short code: WB15L

Item Code	ID (Dash)	ID (mm)	ID (in)	OD (mm)	OD (in)	WP (Mpa)	WP (psi)	BP (Mpa)	BP (psi)	BR (mm)	BR (in)	Weight (kg/m)	Weight (lb/ft)	Length (m)
1003471	6	10,0	3/8"	21,2	0,83	124,0	18000	310,0	45000	150	5,91	0,850	0,58	15,250
1003470	6	10,0	3/8"	21,2	0,83	124,0	18000	310,0	45000	150	5,91	0,850	0,58	20,000
1003473	8	13,0	1/2"	25,8	1,02	110,0	16000	275,0	40000	200	7,87	1,215	0,82	15,250
1003472	8	13,0	1/2"	25,8	1,02	110,0	16000	275,0	40000	200	7,87	1,215	0,82	20,000
1003475	12	19,0	3/4"	32,3	1,27	100,0	14500	250,0	36000	280	11,02	1,683	1,14	15,250
1003474	12	19,0	3/4"	32,3	1,27	100,0	14500	250,0	36000	280	11,02	1,683	1,14	20,000

// WATERBLAST - WB20L

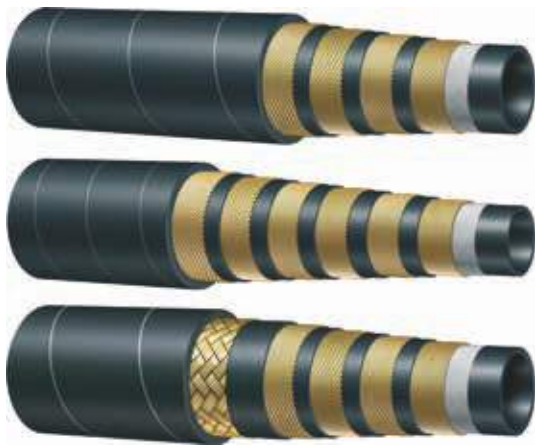

Tube: oil and water resistant synthetic rubber.

Reinforcement: four or six high tensile steel spirals or four high tensile steel spiral and one steel braid.

Cover: oil, water and ozone resistant synthetic rubber.

Application: very high pressure water jetting.

Temperature: -10 °C +70 °C (14 °F +158 °F)

Length: multiples of lengths shown in below grid.

DH SCAN crimp short code: WB20L

Item Code	Constr.	ID (Dash)	ID (in)	ID (mm)	OD (mm)	OD (in)	WP (Mpa)	WP (psi)	BP (Mpa)	BP (psi)	BR (mm)	BR (in)	Weight (kg/m)	Weight (lb/ft)	Length (m)
1004171	4WS	4	1/4"	6,0	16,4	0,65	140,0	20000	350,0	50000	125	4,92	0,574	0,39	15,250
1004172	4WS	4	1/4"	6,0	16,4	0,65	140,0	20000	350,0	50000	125	4,92	0,574	0,39	20,000
1004175	4WS	5	5/16"	8,0	17,3	0,68	140,0	20000	350,0	50000	135	5,31	0,660	0,45	15,250
1004176	4WS	5	5/16"	8,0	17,3	0,68	140,0	20000	350,0	50000	135	5,31	0,660	0,45	20,000
1004178	4WS+1WB	6	3/8"	10,0	22,5	0,89	140,0	20000	350,0	50000	150	5,91	1,021	0,69	15,250
1004179	4WS+1WB	6	3/8"	10,0	22,5	0,89	140,0	20000	350,0	50000	150	5,91	1,021	0,69	20,000
1003798	4WS+1WB	8	1/2"	13,0	26,6	1,05	140,0	20000	350,0	50000	200	7,87	1,433	0,97	15,250
1003799	4WS+1WB	8	1/2"	13,0	26,6	1,05	140,0	20000	350,0	50000	200	7,87	1,433	0,97	20,000
1004181	6WS	12	3/4"	19,0	35,0	1,38	140,0	20000	350,0	50000	300	11,81	2,529	1,70	15,250
1004182	6WS	12	3/4"	19,0	35,0	1,38	140,0	20000	350,0	50000	300	11,81	2,529	1,70	20,000

REV.2.1

// THERMOPLASTIC

// MINIMESS - TPMM

**Pressure test point****Tube:** polyester.**Reinforcement:** one braid of aramid fiber.**Cover:** abrasion, ozone and hydrocarbon resistant polyurethane, pin-pricked.**Application:** high pressure hydraulic lines, fuel oil, antifreeze solutions, air and water.

Specially designed for pressure gauges and transducers connections.

Temperature: -40 °C +100 °C (-40 °F +212 °F) air max T = +70 °C (+160 °F)**Length:** random

Item Code	ID (Dash)	ID (mm)	ID (in)	OD (mm)	OD (in)	WP (Mpa)	WP (psi)	BP (Mpa)	BP (psi)	BR (mm)	BR (in)	Weight (kg/m)	Weight (lb/ft)
1001178	1	2,0	5/64"	5,0	0,20	63,0	9100	190,0	27300	20	0,79	0,020	0,02

// FLEXOR 7

**SAE 100 R7 - EN 855 R7****Tube:** polyester.**Reinforcement:** one/two high tensile textile braids.**Cover:** abrasion, ozone and hydrocarbon resistant polyurethane, pin-pricked.**Application:** high pressure hydraulic lines, fuel oil, antifreeze solutions, air and water.**Temperature:** -40 °C +100 °C (-40 °F +212 °F) air max T = +70 °C (+160 °F)**Length:** random**DH SCAN crimp short code:** TP066

Item Code	ID (Dash)	ID (mm)	ID (in)	OD (mm)	OD (in)	WP (Mpa)	WP (psi)	BP (Mpa)	BP (psi)	BR (mm)	BR (in)	Weight (kg/m)	Weight (lb/ft)
1000290	3	5,0	3/16"	9,6	0,38	21,0	3000	84,0	12000	25	0,98	0,060	0,05
1000291	4	6,0	1/4"	12,2	0,48	21,0	3000	84,0	12000	35	1,38	0,100	0,07
1000292	5	8,0	5/16"	14,3	0,56	19,0	2750	76,0	11000	45	1,77	0,130	0,09
1000293	6	10,0	3/8"	16,0	0,63	16,0	2320	64,0	9280	55	2,17	0,145	0,10
1000294	8	13,0	1/2"	20,3	0,80	14,0	2000	56,0	8000	75	2,95	0,220	0,15

// FLEXOR 7 - TWIN



SAE 100 R7 - EN 855 R7

Tube: polyester.
Reinforcement: one/two high tensile textile braids.
Cover: abrasion, ozone and hydrocarbon resistant polyurethane, pin-pricked.
Application: high pressure hydraulic lines, fuel oil, antifreeze solutions, air and water.
Temperature: -40 °C +100 °C (-40 °F +212 °F)
 air max T = +70 °C (+160 °F)
Length: random
DH SCAN crimp short code: TP063

Item Code	ID (Dash)	ID (mm)	ID (in)	OD (mm)	OD (in)	WP (Mpa)	WP (psi)	BP (Mpa)	BP (psi)	BR (mm)	BR (in)	Weight (kg/m)	Weight (lb/ft)
1000298	4	6,0	1/4"	12,2	0,48	21,0	3000	84,0	12000	35	1,38	0,200	0,14
1000299	5	8,0	5/16"	14,3	0,56	19,0	2750	76,0	11000	45	1,77	0,260	0,18
1000300	6	10,0	3/8"	16,0	0,63	16,0	2320	64,0	9280	55	2,17	0,290	0,20
1000301	8	13,0	1/2"	20,3	0,80	14,0	2000	56,0	8000	75	2,95	0,440	0,30

// FLEXOR 8



SAE 100 R8 - EN 855 R8

Tube: polyester.
Reinforcement: one/two braids of aramid fiber.
Cover: abrasion, ozone and hydrocarbon resistant polyurethane, pin-pricked.
Application: high pressure hydraulic lines, fuel oil, antifreeze solutions, air and water.
Temperature: -40 °C +100 °C (-40 °F +212 °F)
 air max T = +70 °C (+160 °F)
Length: random
DH SCAN crimp short code: TP075

Item Code	ID (Dash)	ID (mm)	ID (in)	OD (mm)	OD (in)	WP (Mpa)	WP (psi)	BP (Mpa)	BP (psi)	BR (mm)	BR (in)	Weight (kg/m)	Weight (lb/ft)
1000295	4	6,0	1/4"	11,5	0,45	35,0	5000	140,0	20000	50	1,97	0,085	0,06
1000483	5	8,0	5/16"	13,4	0,53	30,0	4300	120,0	17450	55	2,17	0,105	0,08
1000296	6	10,0	3/8"	15,5	0,61	28,0	4000	112,0	16000	60	2,36	0,135	0,10
1000416	8	13,0	1/2"	19,9	0,78	24,5	3500	98,0	14000	80	3,15	0,200	0,14

// FLEXOR 8 - TWIN



SAE 100 R8 - EN 855 R8

Tube: polyester.
Reinforcement: one/two braids of aramid fiber.
Cover: abrasion, ozone and hydrocarbon resistant polyurethane, pin-pricked.
Application: high pressure hydraulic lines, fuel oil, antifreeze solutions, air and water.
Temperature: -40 °C +100 °C (-40 °F +212 °F)
 air max T = +70 °C (+160 °F)
Length: random
DH SCAN crimp short code: TP175

Item Code	ID (Dash)	ID (mm)	ID (in)	OD (mm)	OD (in)	WP (Mpa)	WP (psi)	BP (Mpa)	BP (psi)	BR (mm)	BR (in)	Weight (kg/m)	Weight (lb/ft)
1001423	4	6,0	1/4"	11,5	0,45	35,0	5000	140,0	20000	50	1,97	0,085	0,06
1001449	5	8,0	5/16"	13,4	0,53	30,0	4300	120,0	17450	55	2,17	0,105	0,08
1001450	6	10,0	3/8"	15,5	0,61	28,0	4000	112,0	16000	60	2,36	0,135	0,10
1001255	8	13,0	1/2"	19,9	0,78	24,5	3500	98,0	14000	80	3,15	0,200	0,14

REV.2.1

// FLEXOR HR8 - TWIN



MSHA

Hybrid Reinforcement
SAE 100 R8 - EN 855 R8
Tube: polyester.**Reinforcement:** one aramid fiber braid and one steel wire braid.**Cover:** abrasion, ozone and hydrocarbon resistant polyurethane, non pin-pricked.**Application:** high pressure hydraulic lines, fuel oil, antifreeze solutions, air and water.**Temperature:** -40 °C +100 °C (-40 °F +212 °F)
air max T = +70 °C (+160 °F)**Length:** random**DH SCAN crimp short code:** TP1884

Item Code	ID (Dash)	ID (mm)	ID (in)	OD (mm)	OD (in)	WP (Mpa)	WP (psi)	BP (Mpa)	BP (psi)	BR (mm)	BR (in)	Weight (kg/m)	Weight (lb/ft)
1003435	6	10,0	3/8"	15,8	0,62	28,0	4000	112,0	16000	60	2,36	0,460	0,31

// FLEXOR TWB1

**One wire braid****Tube:** polyester.**Reinforcement:** one high tensile steel braid.**Cover:** abrasion, ozone and hydrocarbon resistant polyurethane, non pin-pricked.**Application:** high pressure hydraulic lines, fuel oil, antifreeze solutions, air and water.**Temperature:** -40 °C +100 °C (-40 °F +212 °F)
air max T = +70 °C (+160 °F)**Length:** random**DH SCAN crimp short code:** TP087

Item Code	ID (Dash)	ID (mm)	ID (in)	OD (mm)	OD (in)	WP (Mpa)	WP (psi)	BP (Mpa)	BP (psi)	BR (mm)	BR (in)	Weight (kg/m)	Weight (lb/ft)
1000282	3	5,0	3/16"	9,7	0,38	36,0	5240	144,0	20800	30	1,18	0,120	0,09
1000284	5	8,0	5/16"	13,2	0,52	25,0	3630	100,0	14500	55	2,17	0,190	0,13
1000285	6	10,0	3/8"	15,5	0,61	22,5	3250	90,0	13000	65	2,56	0,230	0,16

// FLEXOR TWB1-CO₂**Tube:** polyester.**Reinforcement:** one high tensile steel braid.**Cover:** abrasion, ozone and hydrocarbon resistant polyurethane, pin-pricked.**Application:** high pressure hydraulic lines, fuel oil, antifreeze solutions, air and water.Specially designed for CO₂ applications.**Temperature:** -40 °C +100 °C (-40 °F +212 °F)
air max T = +70 °C (+160 °F)**Length:** random**DH SCAN crimp short code:** TP050

Item Code	ID (Dash)	ID (mm)	ID (in)	OD (mm)	OD (in)	WP (Mpa)	WP (psi)	BP (Mpa)	BP (psi)	BR (mm)	BR (in)	Weight (kg/m)	Weight (lb/ft)
1001469	4	6,0	1/4"	11,7	0,46	27,5	4000	110,0	16000	40	1,57	0,155	0,11
1001470	8	13,0	1/2"	18,8	0,74	17,5	2500	70,0	10000	85	3,35	0,300	0,21

// FLEXOR TWB1 - TWIN



One wire braid - Twin

Tube: polyester.

Reinforcement: one high tensile steel braid.

Cover: abrasion, ozone and hydrocarbon resistant polyurethane, non pin-pricked.

Application: high pressure hydraulic lines, fuel oil, antifreeze solutions, air and water.

Temperature: -40 °C +100 °C (-40 °F +212 °F)

air max T = +70 °C (+160 °F)

Length: random

DH SCAN crimp short code: TP088

Item Code	ID (Dash)	ID (mm)	ID (in)	OD (mm)	OD (in)	WP (Mpa)	WP (psi)	BP (Mpa)	BP (psi)	BR (mm)	BR (in)	Weight (kg/m)	Weight (lb/ft)
1000289	4	6,0	1/4"	11,7	0,46	31,0	4500	124,0	18000	40	1,57	0,330	0,23
1000288	5	8,0	5/16"	13,2	0,52	25,0	3630	100,0	14500	55	2,17	0,380	0,26
1000287	6	10,0	3/8"	15,5	0,61	22,5	3250	90,0	13000	65	2,56	0,460	0,31
1001167	8	13,0	1/2"	18,8	0,74	19,0	2750	76,0	11000	85	3,35	0,600	0,41

// FLEXOR TWB1 - TRIPLE



Tube: polyester.

Reinforcement: one high tensile steel braid.

Cover: abrasion, ozone and hydrocarbon resistant polyurethane, non pin-pricked.

Application: high pressure hydraulic lines, fuel oil, antifreeze solutions, air and water.

Temperature: -40 °C +100 °C (-40 °F +212 °F)

air max T = +70 °C (+160 °F)

Length: random

DH SCAN crimp short code: TP089

Item Code	ID (Dash)	ID (mm)	ID (in)	OD (mm)	OD (in)	WP (Mpa)	WP (psi)	BP (Mpa)	BP (psi)	BR (mm)	BR (in)	Weight (kg/m)	Weight (lb/ft)
1001179	4	6,0	1/4"	11,6	0,46	27,5	4000	110,0	16000	100	3,94	0,330	0,23
1001228	6	10,0	3/8"	15,5	0,61	21,0	3000	84,0	12000	125	4,92	0,460	0,31

REV.2.1

// FLEXOR MTKH - TWIN

**Heavy Duty****exceeds SAE 100 R8****Tube:** polyester.**Reinforcement:** one/two aramid fiber braid and one steel wire braid.**Cover:** abrasion, ozone and hydrocarbon resistant polyurethane, non pin-pricked.**Application:** high pressure hydraulic lines, fuel oil, antifreeze solutions, air and water.**Temperature:** -40 °C +100 °C (-40 °F +212 °F)

air max T = +70 °C (+160 °F)

Length: random**DH SCAN crimp short code:** TP150

Item Code	ID (Dash)	ID (mm)	ID (in)	OD (mm)	OD (in)	WP (Mpa)	WP (psi)	BP (Mpa)	BP (psi)	BR (mm)	BR (in)	Weight (kg/m)	Weight (lb/ft)
1001447	6	10,0	3/8"	16,9	0,67	42,0	6000	168,0	24000	60	2,36	0,280	0,19
1001448	8	12,5	1/2"	20,3	0,80	35,0	5000	140,0	20000	80	3,15	0,345	0,24

// OFF-SHORE - ROV OPERATION

**Marine high pressure hydraulic - 350 bar (5000 psi)****Tube:** oil and biodegradable hydraulic fluid resistant polyamide 11 methanol washed.**Reinforcement:** high tensile aramid reinforcement.**Cover:** oil, water and ozone resistant polyurethane, non-pin-pricked.**Application:** marine and off-shore equipment, ROVs (remotely operated vehicles), BOP valves.

Suitable for off-shore seismic monitoring operations.

Manufactured according to API 17E / ISO 13628-5.

Temperature: -40 °C to +100 °C (-40 °F to +212 °F)

air and water max T = +70 °C (+160 °F)

Length: random**DH SCAN crimp short code:** OFSM5K

Item Code	ID (mm)	ID (in)	OD (mm)	OD (in)	WP (bar)	WP (psi)	BP (bar)	BP (psi)	BR (mm)	BR (in)	Weight (kg/m)	Weight (lb/ft)
1003750	6,0	1/4"	12,1	0,48	350	5000	1400	20000	50	1,97	0,090	0,07
1003751	10,0	3/8"	17,1	0,67	350	5000	1400	20000	60	2,36	0,170	0,12
1003752	13,0	1/2"	21,9	0,86	350	5000	1400	20000	80	3,15	0,250	0,17
1003753	19,0	3/4"	29,6	1,17	350	5000	1400	20000	150	5,91	0,400	0,27
1003754	25,0	1"	38,6	1,52	350	5000	1400	20000	250	9,84	0,685	0,47

Recommended fitting: AISI 316 SS NPTF male, JIC female and male // Also available in 3000 psi version.

// FLEXOR VHP700



Tube: polyester.

Reinforcement: one/two braids of aramid fiber plus one steel wire braid.

Cover: abrasion, ozone and hydrocarbon resistant polyurethane, non pin-pricked.

Application: high pressure systems and pumps; rescue, safety, jacking and rerailing equipments; bolt tensioning tools.

Temperature: -40 °C +100 °C (-40 °F +212 °F)
air max T = +70 °C (+160 °F)

Length: random

DH SCAN crimp short code: TP041

Item Code	Constr.	ID (Dash)	ID (in)	ID (mm)	OD (mm)	OD (in)	WP (Mpa)	WP (psi)	BP (Mpa)	BP (psi)	BR (mm)	BR (in)	Weight (kg/m)	Weight (lb/ft)
1001237	1TB+1WB	4	1/4"	6,0	12,7	0,50	70,0	10000	280,0	40600	35	1,38	0,120	0,09
1001238	1TB+1WB	6	3/8"	10,0	18,7	0,74	70,0	10000	280,0	40600	90	3,54	0,220	0,15

// FLEXOR 7 - PAINT



SAE 100 R7 - EN 855 R7

Tube: polyamide PA6.

Reinforcement: one/two high tensile textile braids.

Cover: blue abrasion, ozone and hydrocarbon resistant polyurethane, non pin-pricked.

Application: specially designed for airless paint spray applications where high chemical resistance to solvents and aggressive fluids is required.

Temperature: -40 °C +100 °C (-40 °F +212 °F)
air max T = +70 °C (+160 °F)

Length: random

DH SCAN crimp short code: TP098

Item Code	ID (Dash)	ID (mm)	ID (in)	OD (mm)	OD (in)	WP (Mpa)	WP (psi)	BP (Mpa)	BP (psi)	BR (mm)	BR (in)	Weight (kg/m)	Weight (lb/ft)
1001168	3	5,0	3/16"	9,6	0,38	21,0	3000	84,0	12000	25	0,98	0,060	0,05
1001169	4	6,0	1/4"	12,2	0,48	21,0	3000	84,0	12000	35	1,38	0,095	0,07
1001225	6	10,0	3/8"	16,0	0,63	16,0	2320	64,0	9280	55	2,17	0,140	0,10
1001209	8	13,0	1/2"	20,3	0,80	14,0	2000	56,0	8000	75	2,95	0,210	0,15

// FLEXOR TWB1 - PAINT



Tube: polyamide PA6.

Reinforcement: one high tensile steel braid.

Cover: blue abrasion, ozone and hydrocarbon resistant polyurethane, non pin-pricked.

Application: specially designed for airless paint spray applications where high chemical resistance to solvents and aggressive fluids is required. Conductive.

Temperature: -40 °C +100 °C (-40 °F +212 °F)
air max T = +70 °C (+160 °F)

Length: random

DH SCAN crimp short code: TP083

Item Code	ID (Dash)	ID (mm)	ID (in)	OD (mm)	OD (in)	WP (Mpa)	WP (psi)	BP (Mpa)	BP (psi)	BR (mm)	BR (in)	Weight (kg/m)	Weight (lb/ft)
1001156	3	5,0	3/16"	9,7	0,38	36,0	5240	144,0	20800	30	1,18	0,120	0,09
1001157	4	6,0	1/4"	11,7	0,46	31,0	4500	124,0	18000	40	1,57	0,150	0,11
1001158	6	10,0	3/8"	15,5	0,61	22,5	3250	90,0	13000	65	2,56	0,225	0,16
1001159	8	13,0	1/2"	18,8	0,74	19,0	2750	76,0	11000	85	3,35	0,295	0,20

REV.2.1

// FLEXOR TWB2 - PAINT

**Tube:** polyamide PA6.**Reinforcement:** two high tensile steel braids.**Cover:** blue abrasion, ozone and hydrocarbon resistant polyurethane, non pin-pricked.**Application:** specially designed for airless paint spray applications where high chemical resistance to solvents and aggressive fluids is required. Conductive.**Temperature:** -40 °C +100 °C (-40 °F +212 °F)
air max T = +70 °C (+160 °F)**Length:** random**DH SCAN crimp short code:** TP081

Item Code	ID (Dash)	ID (mm)	ID (in)	OD (mm)	OD (in)	WP (Mpa)	WP (psi)	BP (Mpa)	BP (psi)	BR (mm)	BR (in)	Weight (kg/m)	Weight (lb/ft)
1001211	4	6,0	1/4"	12,8	0,50	42,5	6100	170,0	24400	40	1,57	0,240	0,17
1001226	6	10,0	3/8"	16,8	0,66	35,0	5000	140,0	20000	65	2,56	0,370	0,25
1001321	8	13,0	1/2"	20,2	0,80	30,0	4300	120,0	17450	85	3,35	0,445	0,30

// PTFE

// 9TS OM

**Smooth PTFE Stainless Steel braid - Standard duty****exceeds SAE 100 R14**

Tube: smooth PTFE - high mechanical and vibration resistance, low permeability, dielectrical, fire resistant, food grade (FDA, DVGW, BFR compliant). Chemically inert, non sticking, ozone and weather resistant.

Reinforcement: high tensile stainless steel braid AISI 304.

Application: compressed air, gas, steam, fuel, oil, chemical and pharmaceutical products, particularly suitable for steam piping on injection moulding machines, diathermic oil installations, charging lines for cryogenic gas, compressor discharge lines, automotive, pharmaceutical and food sectors. Solvents, pigments and paint transfer lines. Hydraulic lines in power steering marine applications.

Not suitable for molten alkali metals and halogens at high temperature.

Temperature: -60 °C +260 °C (-76 °F +500 °F)

DH SCAN crimp short code: 9TS

Item Code	ID (mm)	ID (in)	OD (mm)	Innertube T (mm)	WP (Mpa)	WP (psi)	BR (mm)	BR (in)	Weight (kg/m)
2600557	5,0	3/16"	7,9	0,89	27,6	4000	51	2,01	0,090
2600558	6,0	1/4"	8,6	0,64	24,1	3500	76	2,99	0,090
2600559	8,0	5/16"	11,1	0,64	20,7	3000	102	4,02	0,130
2600560	10,0	3/8"	12,7	0,64	18,3	2600	127	5,00	0,150
2600561	13,0	1/2"	15,4	0,76	16,1	2300	140	5,51	0,200
2600562	16,0	5/8"	18,4	0,89	13,8	2000	165	6,50	0,270
2600563	19,0	3/4"	22,1	0,89	11,4	1600	203	7,99	0,330
2600564	25,0	1"	29,8	1,1	6,9	1000	305	12,01	0,520

REV.2.1

// 9TC OM

**Convoluted PTFE Stainless Steel braid**

Tube: convoluted PTFE - high mechanical and vibration resistance, low permeability, dielectrical, fire resistant, food grade (FDA, DVGW, BFR compliant). Chemically inert, non sticking, ozone and weather resistant.

Reinforcement: high tensile stainless steel braid AISI 304.

Application: compressed air, gas, steam, fuel, oil, chemical and pharmaceutical products, particularly suitable for steam piping on injection moulding machines, diathermic oil installations, charging lines for cryogenic gas, compressor discharge lines, automotive, pharmaceutical and food sectors. Solvents, pigments and paint transfer lines. Hydraulic lines in power steering marine applications.

Not suitable for molten alkali metals and halogens at high temperature.

Temperature: -60 °C +260 °C (-76 °F +500 °F)

DH SCAN crimp short code: 9TC

Item Code	ID (mm)	ID (in)	OD (mm)	Innertube T (mm)	WP (Mpa)	WP (psi)	BR (mm)	BR (in)	Weight (kg/m)
2600574	13,0	1/2"	18,8	0,89	10,3	1500	25	0,98	0,280
2600575	16,0	5/8"	22,1	0,89	8,3	1200	51	2,01	0,330
2600576	19,0	3/4"	24,6	0,89	6,9	1000	64	2,52	0,400
2600577	25,0	1"	32,8	1,02	4,6	670	89	3,50	0,550
2600578	32,0	1 1/4"	40,7	1,02	3,4	525	127	5,00	0,690
2600579	38,0	1 1/2"	48,2	1,12	3,0	450	152	5,98	0,890
2600580	51,0	2"	61,5	1,2	2,3	345	200	7,87	1,240



// FERRULE SELECTION CHART

// NO SKIVE FERRULE FOR STANDARD FITTINGS.....	35
// SKIVE FERRULE FOR STANDARD FITTINGS.....	35
// NO SKIVE FERRULE FOR NEW POWERTRAK FITTINGS.....	36

// NO SKIVE FERRULE FOR STANDARD FITTINGS

Hose	Table n°	-03 DN 5 3/16"	-04 DN 6 1/4"	-05 DN 8 5/16"	-06 DN 10 3/8"	-08 DN 12 1/2"	-10 DN 16 5/8"	-12 DN 19 3/4"	-16 DN 25 1"	-20 DN 32 1 1/4"	-24 DN 38 1 1/2"	-32 DN 51 2"	-40 DN 63 2 1/2"
ARGUS 1TE/R6	209		H1100SK1	H1100SK1	H1100SK1	H1100SK1	H1100SK1	H1100SK1	H1100SK1				
ARGUS 2TE	210		H1100SK1	H1100SK1	H1100SK1	H1100SK1	H1100404	H1100404	H1100SK1				
2TE RAILWAY	210		H1100SK1	H1100SK1	H1100SK1	H1100SK1	H1100404	H1100404	H1100SK1				
ARGUS 3TE/R3 PLUS	252		H1200TX2	H1200TX2	H1200TX2	H1200TX2	H1200TX2	H1200TX2	H1200TX2	H1200TX2	H1200TX2	H1200TX2	
FLEXOR TWB1	200	H1200TP0	H1200TP0	H1200TP0	H1200TP0	H1200TP0	H1200TP0	H1200TP0	H1200TP0				
FLEXOR 7	198	H1200TP0	H1200TP0	H1200TP0	H1200TP0	H1200TP0							
FLEXOR 8	199	H1200TP0	H1200TP0	H1200TP0	H1200TP0	H1200TP0							
121T SLIMLINE PLUS - 1SC	178		H1200AD1	H1200AD1	H1200AD1	H1200AD1	H1200AD1	H1200AD1	H1200AD1				
	206	H1200TP0		H1200TP0	H1200TP0	H1200TP0							
141T SUPERSLIMLINE	185		H1200AD1	H1200AD1	H1200AD1	H1200AD1							
ALFAJET 210	185		H1200AD1	H1200AD1	H1200AD1	H1200AD1							
221T SLIMLINE PLUS - 2SC	176		H1200AD1	H1200AD1	H1200AD1	H1200AD1	H1200AD1	H1200AD1	H1200AD1				
2SC RAILWAY	176		H1200AD1	H1200AD1	H1200AD1	H1200AD1	H1200AD1	H1200AD1	H1200AD1				
ALFAJET 400	176		H1200AD1	H1200AD1	H1200AD1	H1200AD1							
241T SUPERSLIMLINE - HI-TUFF	177		H1200AD1	H1200AD1	H1200AD1	H1200AD1	H1200AD1	H1200AD1	H1200AD2	H1200AD1	H1200AD1	H1200AD1	H1200TX2
241X SUPERSLIMLINE - TUFLEX	177		H1200AD1	H1200AD1	H1200AD1	H1200AD1	H1200AD1	H1200AD1	H1200AD2				
261E HYPERCOLD SUPERSLIMLINE	177		H1200AD1	H1200AD1	H1200AD1	H1200AD1	H1200AD1	H1200AD1	H1200AD2	H1200AD1			
122T GREENLINE PLUS - 1SN/R1AT	173	H1200AD1	H1200AD1	H1200AD1	H1200AD1	H1200AD1	H1200AD1	H1200AD1	H1200AD2	H1200AD1	H1200AD1	H1200AD1	
COMMANDER 150 1SN PLUS	173	H1200AD1	H1200AD1	H1200AD1	H1200AD1	H1200AD1	H1200AD1	H1200AD1	H1200AD2	H1200AD1	H1200AD1	H1200AD1	
222T GREENLINE PLUS - 2SN/R2AT	174	H1200AD2	H1200AD2	H1200AD2	H1200AD2	H1200AD2	H1200AD2	H1200AD2	H1200AD2	H1200AD2	H1200AD2	H1200AD2	
POWERFLEXBIO 3000 - HI-TUFF	186									H1200204	H1200204		
POWERFLEXBIO 4000 - HI-TUFF	194							H1200204	H1200204	H1200204			
FLEXOR R4 604/634/644	018							H1200TX2	H1200TX2	H1200TX2	H1200TX2	H1200TX2	H1200TX2
9TS OM	201	H2200TF0	H2200TF0	H2200TF0	H2200TF0	H2200TF0	H2200TF0	H2200TF0	H2200TF0				
9TC OM	203				H2200TF0	H2200TF0	H2200TF0	H2200TF0	H2200TF0	H2200TF0	H2200TF0	H2200TF0	

// SKIVE FERRULE FOR STANDARD FITTINGS

Hose	Table n°	-03 DN 5 3/16"	-04 DN 6 1/4"	-05 DN 8 5/16"	-06 DN 10 3/8"	-08 DN 12 1/2"	-10 DN 16 5/8"	-12 DN 19 3/4"	-16 DN 25 1"	-20 DN 32 1 1/4"	-24 DN 38 1 1/2"	-32 DN 51 2"	-40 DN 63 2 1/2"	-48 DN 76 3"
3SPT SUPERFOREST	DH 33				H1100404	H1100404	H1100404	H1100404	H1100404	H1100404				
3SPE SUPERFOREST LT	DH 33				H1100404	H1100404	H1100404	H1100404	H1100404	H1100404				
POWERFLEXBIO 3000 - HI-TUFF	229									H1100404	H1100404	H1100404*		
POWERFLEXBIO 4000 - HI-TUFF	187					H1100404		H1100404	H1100404					
POWERFLEXBIO 5000 - HI-TUFF	188						H1100404	H1100404	H1100404					
POWERFLEXBIO 5000 PLUS - HI-TUFF	211							H1100404						
POWERFLEXBIO 6000 - HI-TUFF	192		H1100404		H1100404	H1100404								
BOP - FIRESAFE 5000	306		H1100404		H1100404	H1100404		H1100404						

* validated at 175 bar (2500 PSI) according to SAE R12 - table 229

// INTERLOCK FERRULE FOR INTERLOCK FITTINGS

Hose	Table n°	-06 DN 10 3/8"	-08 DN 12 1/2"	-10 DN 16 5/8"	-12 DN 19 3/4"	-16 DN 25 1"	-20 DN 32 1 1/4"	-24 DN 38 1 1/2"	-32 DN 51 2"	-40 DN 63 2 1/2"	-48 DN 76 3"
POWERFLEXBIO 3000 - HI-TUFF	217										H1T00600*
POWERFLEXBIO 4000 - HI-TUFF	195					H1400200		H1400200	H1400200		
POWERFLEXBIO 5000 - HI-TUFF	189				H1400200	H1400200	H1400200	H1400301	H1400301		
	251								H1T00600*	H1T00600*	H1T00600*
POWERFLEXBIO 5000 PLUS - HI-TUFF	190				H1400200	H1400200					
POWERFLEXBIO 6000 - HI-TUFF - 4S	191			H1400301	H1400200	H1400200	H1400301				
POWERFLEXBIO 6000 - HI-TUFF - 6S							H1400301	H1400301			
POWERFLEXBIO 6000 - HI-TUFF - 6S	272								H1T00600*		
AT7K - MINETUFF	101			H1400301			H1400301	H1400301			
AT8K - MINETUFF - 4S	102				H1400301	H1T00600*					
AT8K - MINETUFF - 6S					H1400301						
BOP - FIRESAFE 5000	307					H1400200	H1400200	H1400301	H1400301		

* suitable with only Dunlop Hiflex H1T special inserts

Hose	Table n°	-03 DN 5 3/16"	-04 DN 6 1/4"	-05 DN 8 5/16"	-06 DN 10 3/8"	-08 DN 12 1/2"	-10 DN 16 5/8"	-12 DN 19 3/4"	-16 DN 25 1"	-20 DN 32 1 1/4"	-24 DN 38 1 1/2"
WATERBLAST - WB10L	281					H1400200*		H1400200*	H1400200*		
	-				D990000	D990000		D990000	D990000		
WATERBLAST - WB15L	284				D990000	D990000		D990000			
WATERBLAST - WB20L	285		D990000	D990000	D980000	D980000		D980000			

* to be used with Interlock H14 series inserts

// NO SKIVE FERRULE FOR NEW POWERTRAK FITTINGS

Hose	Table n°	-06 DN 10 3/8"	-08 DN 12 1/2"	-10 DN 16 5/8"	-12 DN 19 3/4"	-16 DN 25 1"	-20 DN 32 1 1/4"	-24 DN 38 1 1/2"	-32 DN 51 2"	-40 DN 63 2 1/2"	-48 DN 76 3"
POWERFLEXBIO 4000 - HI-TUFF	275							H1300NS4	H1300NS4		
POWERFLEXBIO 5000 - HI-TUFF - 4S	276				H1300NS4	H1300NS4	H1300NS4				
POWERFLEXBIO 5000 - HI-TUFF - 6S	280							H1300NS6	H1300NS6		
POWERFLEXBIO 5000 PLUS - HI-TUFF	277				H1300NS4	H1300NS4					
POWERFLEXBIO 6000 - HI-TUFF - 4S	278				H1300NS4	H1300NS4					
POWERFLEXBIO 6000 - HI-TUFF - 6S	282						H1300NS6				

**SAFE, RELIABLE
& FULLY INTEGRATED
FLUID HANDLING SYSTEM**

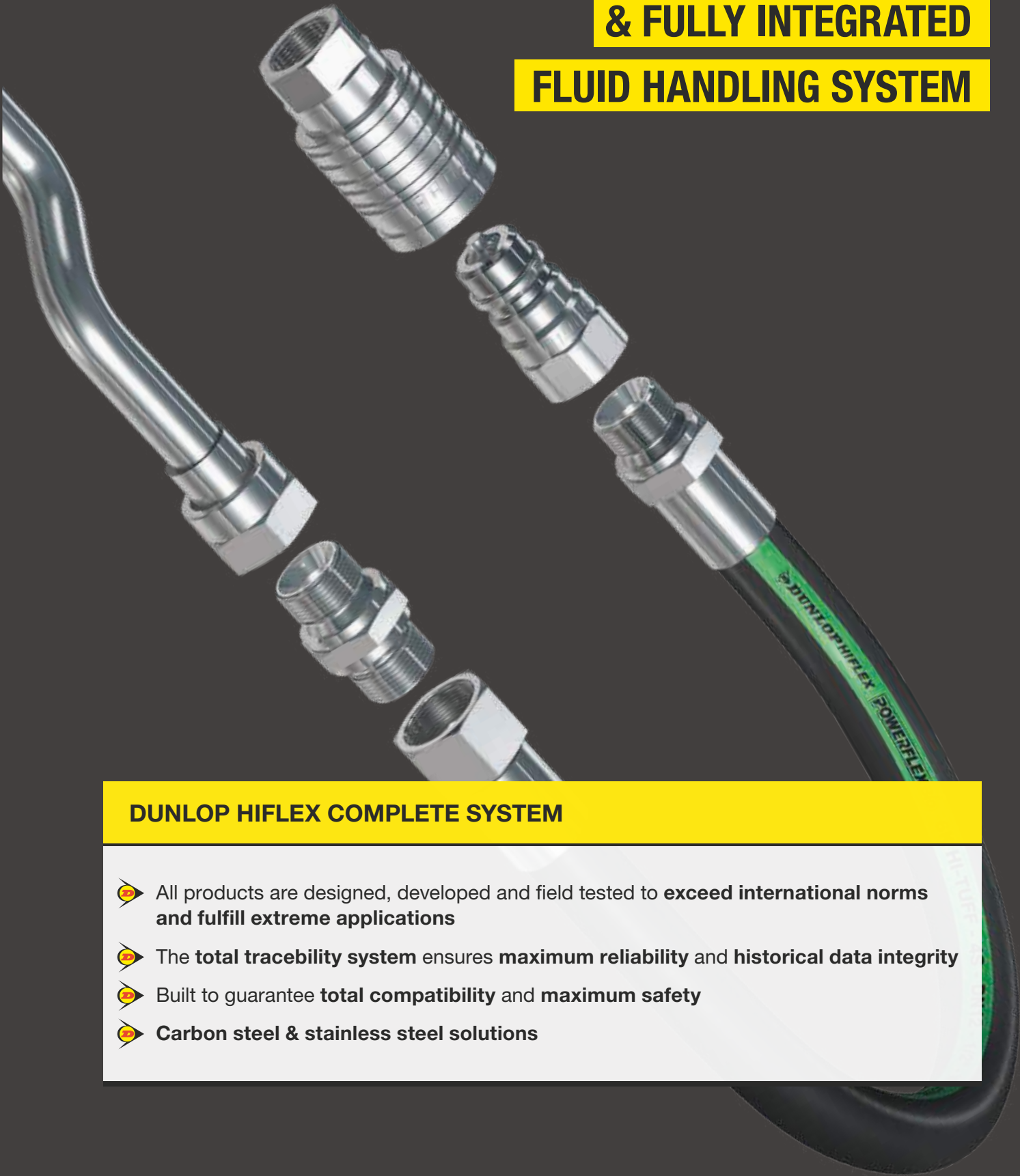

DUNLOP HIFLEX COMPLETE SYSTEM

- All products are designed, developed and field tested to **exceed international norms and fulfill extreme applications**
- The **total traceability system** ensures **maximum reliability** and **historical data integrity**
- Built to guarantee **total compatibility** and **maximum safety**
- **Carbon steel & stainless steel solutions**

 **DUNLOP HIFLEX**



ALSO AVAILABLE IN STAINLESS STEEL

// STANDARD FITTINGS

// FERRULES	39	// NPTF INSERTS	75
// HOSE MENDER	44	// NPSM INSERTS	77
// BSP INSERTS	45	// ORFS INSERTS	78
// DIN METRIC INSERTS	52	// FRENCH INSERTS	81
// PRESSURE WASHER	64	// JIS INSERTS	82
// SAE INSERTS	65	// KOMATSU INSERTS	84
// JIC 37° INSERTS	67	// SAE FLANGES	86

// FERRULES

// H1200TX2

No-Skive Ferrule for 3TE, R5 and Flexopak 2 Minetuff 2 1/2" - 241T Hi-tuff hoses

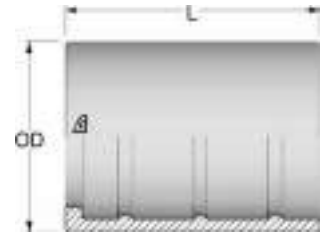

Item Code	Product Code	ID (Dash)	ID (mm)	ID (in)	Ferrule OD (mm)	L (mm)
1236581	H1200TX2-030000	3	5,0	3/16"	21,0	20,0
1236582	H1200TX2-040000	4	6,0	1/4"	23,0	24,7
1236583	H1200TX2-050000	5	8,0	5/16"	25,0	24,7
1236584	H1200TX2-060000	6	10,0	3/8"	27,0	29,7
1236585	H1200TX2-080000	8	13,0	1/2"	30,0	30,5
1236586	H1200TX2-100000	10	16,0	5/8"	34,0	35,5
1236587	H1200TX2-120000	12	19,0	3/4"	38,0	36,0
1236588	H1200TX2-160000	16	25,0	1"	48,0	42,5
1236589	H1200TX2-200000	20	31,0	1 1/4"	53,0	56,5
1236590	H1200TX2-240000	24	38,0	1 1/2"	60,0	61,5
1236591	H1200TX2-320000	32	51,0	2"	76,0	73,5
1236592	H1200TX2-400000	40	63,0	2 1/2"	89,0	85,0

// H1200TX4

No-Skive Ferrule for R4 Hoses (604, 634, 644)

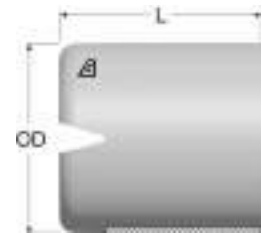

Item Code	Product Code	ID (Dash)	ID (mm)	ID (in)	Ferrule OD (mm)	L (mm)
1250572	H1200TX4-120000	12	19,0	3/4"	36,0	39,0
1250581	H1200TX4-160000	16	25,0	1"	42,4	44,3
1250582	H1200TX4-200000	20	31,0	1 1/4"	50,0	53,2
1250583	H1200TX4-240000	24	38,0	1 1/2"	55,0	60,2
1250584	H1200TX4-320000	32	51,0	2"	70,0	73,2
1250585	H1200TX4-400000	40	63,0	2 1/2"	83,0	86,0

// H1200103

No-Skive Ferrule for PLT

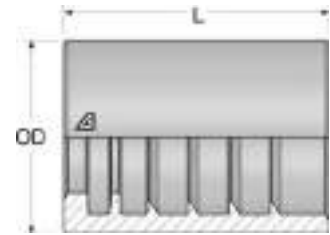

ID (Dash)	ID (mm)	ID (in)	Ferrule OD (mm)	L (mm)
3	5,0	3/16"	17,0	23,0
4	6,0	1/4"	19,0	26,3

// H1200AD1

No-Skive Ferrule for 1 Wire Braid and 2 Wire Braid Compact Hoses

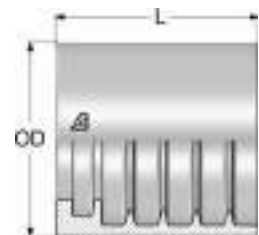

Item Code	Product Code	ID (Dash)	ID (mm)	ID (in)	Ferrule OD (mm)	L (mm)
1227977	H1200AD1-030000	3	5,0	3/16"	19,0	24,0
1227978	H1200AD1-040000	4	6,0	1/4"	22,0	24,7
1227979	H1200AD1-050000	5	8,0	5/16"	23,0	24,7
1227980	H1200AD1-060000	6	10,0	3/8"	26,0	29,7
1227981	H1200AD1-080000	8	13,0	1/2"	29,0	30,5
1227983	H1200AD1-100000	10	16,0	5/8"	32,0	30,5
1227985	H1200AD1-120000	12	19,0	3/4"	36,0	36,0
1227986	H1200AD1-160000	16	25,0	1"	44,0	36,7
1227987	H1200AD1-200000	20	31,0	1 1/4"	53,0	48,6
1227988	H1200AD1-240000	24	38,0	1 1/2"	61,0	48,6
1227989	H1200AD1-320000	32	51,0	2"	75,0	48,6

REV.2.1

// H1200AD2

No-Skive Ferrule for 2SN

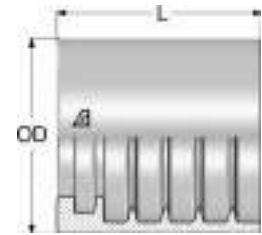

Item Code	Product Code	ID (Dash)	ID (mm)	ID (in)	Ferrule OD (mm)	L (mm)
1227990	H1200AD2-030000	3	5,0	3/16"	21,0	20,0
1227991	H1200AD2-040000	4	6,0	1/4"	23,0	24,7
1227992	H1200AD2-050000	5	8,0	5/16"	25,0	24,7
1227993	H1200AD2-060000	6	10,0	3/8"	27,0	29,7
1227994	H1200AD2-080000	8	13,0	1/2"	30,0	30,5
1227995	H1200AD2-100000	10	16,0	5/8"	33,0	30,5
1227996	H1200AD2-120000	12	19,0	3/4"	37,0	36,0
1227997	H1200AD2-160000	16	25,0	1"	45,0	36,7
1227998	H1200AD2-200000	20	31,0	1 1/4"	56,0	48,6
1227999	H1200AD2-240000	24	38,0	1 1/2"	64,0	48,5
1228000	H1200AD2-320000	32	51,0	2"	78,0	48,6

// H1200204

No-Skive Ferrule for Alfabiotech/Powerflexbio Hoses

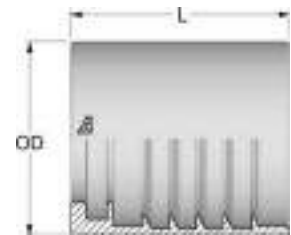

Item Code	Product Code	ID (Dash)	ID (mm)	ID (in)	Ferrule OD (mm)	L (mm)
1216588	H1200204-060000	6	10,0	3/8"	30,0	28,0
1216589	H1200204-080000	8	13,0	1/2"	34,0	33,9
1216590	H1200204-100000	10	16,0	5/8"	38,0	36,6
1203322	H1200204-120000	12	19,0	3/4"	42,0	39,5
1203323	H1200204-160000	16	25,0	1"	50,0	47,5
1216591	H1200204-200000	20	31,0	1 1/4"	61,0	50,2

// H1200TP0

No-Skive Ferrule for Thermoplastic and 1 Wire Braid Compact Hoses

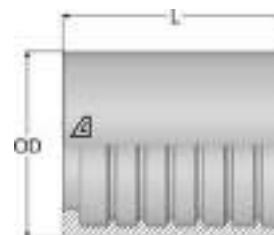

Item Code	Product Code	ID (Dash)	ID (mm)	ID (in)	Ferrule OD (mm)	L (mm)
1232354	H1200TP0-030000	3	5,0	3/16"	15,0	22,0
1232358	H1200TP0-040000	4	6,0	1/4"	17,0	26,5
1232359	H1200TP0-050000	5	8,0	5/16"	19,0	26,5
1232360	H1200TP0-060000	6	10,0	3/8"	22,0	26,5
1232361	H1200TP0-080000	8	13,0	1/2"	26,0	30,5

// H2200TF0

No-Skive Ferrule for PTFE Hoses

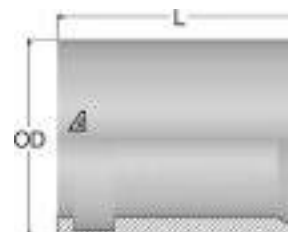

Item Code	Product Code	ID (Dash)	ID (mm)	ID (in)	Ferrule OD (mm)	L (mm)
1232132	H2200TF0-030000	3	5,0	3/16"	14,0	20,0
1232133	H2200TF0-040000	4	6,0	1/4"	15,0	25,0
1232134	H2200TF0-050000	5	8,0	5/16"	17,2	25,0
1232135	H2200TF0-060000	6	10,0	3/8"	22,0	25,0
1232136	H2200TF0-080000	8	13,0	1/2"	25,0	30,0
1232137	H2200TF0-100000	10	16,0	5/8"	30,0	33,0
1232138	H2200TF0-120000	12	19,0	3/4"	35,0	37,0
1232139	H2200TF0-160000	16	25,0	1"	42,0	45,0
1232140	H2200TF0-200000	20	31,0	1 1/4"	50,0	48,0
1232141	H2200TF0-240000	24	38,0	1 1/2"	57,0	58,0
1232142	H2200TF0-320000	32	51,0	2"	73,0	67,0

// H1100104

Skive Ferrule for 1SN

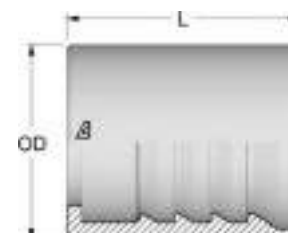

Item Code	Product Code	ID (Dash)	ID (mm)	ID (in)	Ferrule OD (mm)	L (mm)
1201545	H1100104-200000	20	31,0	1 1/4"	50,0	43,8
1201546	H1100104-240000	24	38,0	1 1/2"	57,0	49,2
1201547	H1100104-320000	32	51,0	2"	71,0	63,7

REV.2.1

// H1100404

Skive Ferrule for 2/3 Wire Braid and Wire Spiral Hoses

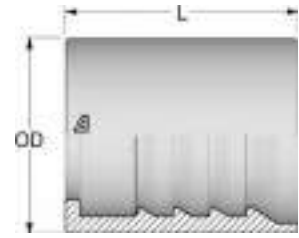

Item Code	Product Code	ID (Dash)	ID (mm)	ID (in)	Ferrule OD (mm)	L (mm)
1202719	H1100404-040000	4	6,0	1/4"	22,0	26,3
1203253	H1100404-060000	6	10,0	3/8"	25,0	28,5
1203266	H1100404-080000	8	13,0	1/2"	29,0	34,7
1219132	H1100404-100000	10	16,0	5/8"	33,0	37,5
1203368	H1100404-120000	12	19,0	3/4"	37,0	41,5
1234701	H1100404-160000	16	25,0	1"	45,0	47,7
1234766	H1100404-200000	20	31,0	1 1/4"	55,0	54,5
1234767	H1100404-240000	24	38,0	1 1/2"	67,0	61,1
1234768	H1100404-320000	32	51,0	2"	82,0	75,1

// H1100SK1

Skive Ferrule for 1 Wire Braid and 2 Wire Braid Compact Hoses
No-Skive for 1TE, 2TE and R6

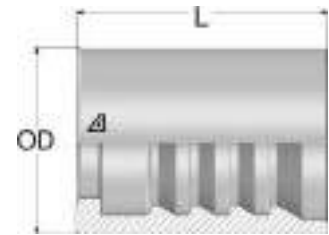

Item Code	Product Code	ID (Dash)	ID (mm)	ID (in)	Ferrule OD (mm)	L (mm)
1233077	H1100SK1-040000	4	6,0	1/4"	19,0	25,5
1233078	H1100SK1-050000	5	8,0	5/16"	21,0	25,5
1233079	H1100SK1-060000	6	10,0	3/8"	23,0	27,5
1233080	H1100SK1-080000	8	13,0	1/2"	27,0	33,5
1233081	H1100SK1-100000	10	16,0	5/8"	30,0	36,5
1233082	H1100SK1-120000	12	19,0	3/4"	33,0	40,0
1233083	H1100SK1-160000	16	25,0	1"	41,0	46,5

// HOSE MENDER

// H12C5610

Hose Mender

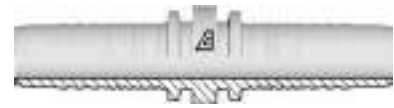

Item Code	Product Code	ID (Dash)	ID (mm)	ID (in)
1202949	H12C5610-040400	4	6,0	1/4"
1202870	H12C5610-050500	5	8,0	5/16"
1202868	H12C5610-060600	6	10,0	3/8"
1202867	H12C5610-080800	8	13,0	1/2"
1203160	H12C5610-101000	10	16,0	5/8"
1203161	H12C5610-121200	12	19,0	3/4"
1220608	H12C5610-161600	16	25,0	1"
1220607	H12C5610-202000	20	32,0	1 1/4"
1220605	H12C5610-242400	24	38,0	1 1/2"
1220606	H12C5610-323200	32	51,0	2"

REV.2.1

// BSP INSERTS

// H1210510

BSP Male 60° Flare
AGR

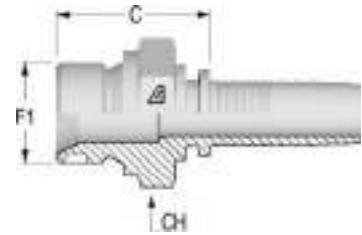

Item Code	Product Code	ID (Dash)	ID (mm)	ID (in)	F1 Dash	F1	C (mm)	CH (mm)
1201291	H1210510-030200	3	5,0	3/16"	2	1/8-28	20,3	14,0
1201722	H1210510-040200	4	6,0	1/4"	2	1/8-28	20,8	14,0
1200507	H1210510-040400	4	6,0	1/4"	4	1/4-19	26,3	19,0
1200508	H1210510-040600	4	6,0	1/4"	6	3/8-19	27,8	22,0
1201098	H1210510-040800	4	6,0	1/4"	8	1/2-14	31,3	27,0
1200540	H1210510-050400	5	8,0	5/16"	4	1/4-19	26,3	19,0
1200541	H1210510-050600	5	8,0	5/16"	6	3/8-19	27,8	22,0
1201101	H1210510-050800	5	8,0	5/16"	8	1/2-14	31,3	27,0
1200340	H1210510-060400	6	10,0	3/8"	4	1/4-19	26,3	19,0
1200341	H1210510-060600	6	10,0	3/8"	6	3/8-19	27,8	22,0
1200339	H1210510-060800	6	10,0	3/8"	8	1/2-14	31,3	27,0
1200386	H1210510-080600	8	13,0	1/2"	6	3/8-19	28,6	22,0
1200384	H1210510-080800	8	13,0	1/2"	8	1/2-14	32,1	27,0
1201096	H1210510-081000	8	13,0	1/2"	10	5/8-14	34,1	30,0
1200385	H1210510-081200	8	13,0	1/2"	12	3/4-14	36,1	32,0
1201085	H1210510-100800	10	16,0	5/8"	8	1/2-14	32,1	27,0
1200419	H1210510-101000	10	16,0	5/8"	10	5/8-14	34,1	30,0
1200418	H1210510-101200	10	16,0	5/8"	12	3/4-14	36,1	32,0
1200446	H1210510-121200	12	19,0	3/4"	12	3/4-14	36,6	32,0
1201095	H1210510-121600	12	19,0	3/4"	16	1-11	41,6	41,0
1201355	H1210510-161600	16	25,0	1"	16	1-11	42,4	41,0
1201356	H1210510-162000	16	25,0	1"	20	1 1/4-11	46,4	50,0
1201357	H1210510-202000	20	32,0	1 1/4"	20	1 1/4-11	48,0	50,0
1201358	H1210510-242400	24	38,0	1 1/2"	24	1 1/2-11	51,0	55,0
1201359	H1210510-323200	32	51,0	2"	32	2-11	56,5	70,0

// H1210610

BSP Male Flat Seat
AGR FD

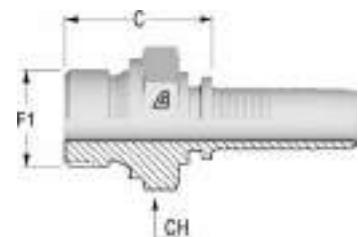

Item Code	Product Code	ID (Dash)	ID (mm)	ID (in)	F1 Dash	F1	C (mm)	CH (mm)
1214181	H1210610-040400	4	6,0	1/4"	4	1/4-19	26,3	19,0
1223423	H1210610-060600	6	10,0	3/8"	6	3/8-19	27,8	22,0
1216596	H1210610-060800	6	10,0	3/8"	8	1/2-14	31,3	27,0
1225012	H1210610-080800	8	13,0	1/2"	8	1/2-14	32,1	27,0

// H1210710

BSPT Male

AGR K

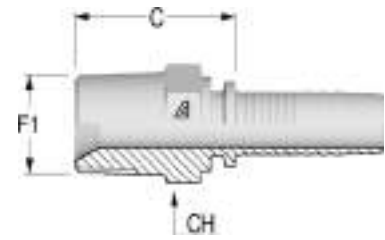

Item Code	Product Code	ID (Dash)	ID (mm)	ID (in)	F1 Dash	F1	C (mm)	CH (mm)
1200456	H1210710-030200	3	5,0	3/16"	2	1/8-28	20,8	12,0
1200491	H1210710-040200	4	6,0	1/4"	2	1/8-28	21,3	12,0
1200490	H1210710-040400	4	6,0	1/4"	4	1/4-19	26,8	17,0
1200492	H1210710-040600	4	6,0	1/4"	6	3/8-19	27,8	19,0
1200532	H1210710-050400	5	8,0	5/16"	4	1/4-19	26,8	17,0
1200533	H1210710-050600	5	8,0	5/16"	6	3/8-19	27,8	19,0
1200328	H1210710-060400	6	10,0	3/8"	4	1/4-19	26,8	17,0
1200329	H1210710-060600	6	10,0	3/8"	6	3/8-19	27,8	19,0
1200327	H1210710-060800	6	10,0	3/8"	8	1/2-14	32,3	22,0
1200373	H1210710-080600	8	13,0	1/2"	6	3/8-19	28,6	19,0
1200371	H1210710-080800	8	13,0	1/2"	8	1/2-14	33,1	22,0
1200410	H1210710-101200	10	16,0	5/8"	12	3/4-14	34,1	27,0
1200440	H1210710-121200	12	19,0	3/4"	12	3/4-14	34,6	27,0
1200439	H1210710-121600	12	19,0	3/4"	16	1-11	43,6	36,0
1201365	H1210710-161200	16	25,0	1"	12	3/4-14	37,4	32,0
1201361	H1210710-161600	16	25,0	1"	16	1-11	44,4	36,0
1201363	H1210710-202000	20	32,0	1 1/4"	20	1 1/4-11	49,0	46,0
1201364	H1210710-242400	24	38,0	1 1/2"	24	1 1/2-11	50,5	50,0
1201360	H1210710-323200	32	51,0	2"	32	2-11	54,2	65,0

REV.2.1

// H1220813

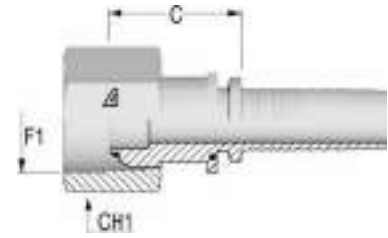
**BSP Female 60° Cone with O-Ring
DKOR**

Item Code	Product Code	Nut Type	ID (Dash)	ID (mm)	ID (in)	F1 Dash	F1	C (mm)	CH1 (mm)
1200606	H1220511-030200	Crimped	3	5,0	3/16"	2	1/8-28	14,3	14,0
1202325	H1220813-030400	Slip on nut	3	5,0	3/16"	4	1/4-19	20,3	19,0
1201066	H1220511-040200	Crimped	4	6,0	1/4"	2	1/8-28	14,7	14,0
1202326	H1220813-040400	Slip on nut	4	6,0	1/4"	4	1/4-19	20,8	19,0
1202327	H1220813-040600	Slip on nut	4	6,0	1/4"	6	3/8-19	23,3	22,0
1202328	H1220811-050400	Crimped	5	8,0	5/16"	4	1/4-19	16,6	19,0
1202329	H1220813-050600	Slip on nut	5	8,0	5/16"	6	3/8-19	23,3	22,0
1202330	H1220811-060400	Crimped	6	10,0	3/8"	4	1/4-19	17,3	19,0
1202331	H1220813-060600	Slip on nut	6	10,0	3/8"	6	3/8-19	23,3	22,0
1202332	H1220813-060800	Slip on nut	6	10,0	3/8"	8	1/2-14	24,3	27,0
1202571	H1220811-080600	Crimped	8	13,0	1/2"	6	3/8-19	18,6	22,0
1202333	H1220813-080800	Slip on nut	8	13,0	1/2"	8	1/2-14	25,1	27,0
1202334	H1220813-081000	Slip on nut	8	13,0	1/2"	10	5/8-14	28,4	27,0
1202335	H1220813-081200	Slip on nut	8	13,0	1/2"	12	3/4-14	29,0	32,0
1202457	H1220811-101000	Crimped	10	16,0	5/8"	10	5/8-14	17,1	27,0
1202336	H1220813-101200	Slip on nut	10	16,0	5/8"	12	3/4-14	29,0	32,0
1202462	H1220811-121200	Crimped	12	19,0	3/4"	12	3/4-14	23,9	32,0
1202337	H1220813-121600	Slip on nut	12	19,0	3/4"	16	1-11	34,0	38,0
1202455	H1220811-161600	Crimped	16	25,0	1"	16	1-11	23,9	38,0
1202338	H1220813-162000	Slip on nut	16	25,0	1"	20	1 1/4-11	39,4	50,0
1202458	H1220812-202000	Thrust wire nut	20	32,0	1 1/4"	20	1 1/4-11	32,0	50,0
1202339	H1220813-202400	Slip on nut	20	32,0	1 1/4"	24	1 1/2-11	41,9	55,0
1202463	H1220812-242400	Thrust wire nut	24	38,0	1 1/2"	24	1 1/2-11	33,8	55,0
1202340	H1220813-243200	Slip on nut	24	38,0	1 1/2"	32	2-11	47,0	70,0
1202014	H1220812-323200	Thrust wire nut	32	51,0	2"	32	2-11	34,0	70,0

Image: insert with Slip on Nut.

// H1220843

45° BSPF Female 60° Cone with O-Ring

DKOR 45

Solid one piece

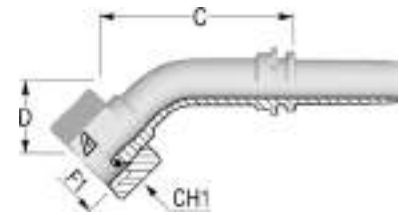

Item Code	Product Code	Nut Type	ID (Dash)	ID (mm)	ID (in)	F1 Dash	F1	C (mm)	D Drop (mm)	CH1 (mm)
1202341	H1220843-040400	Slip on nut	4	6,0	1/4"	4	1/4-19	45,5	15,0	19,0
1202342	H1220843-040600	Slip on nut	4	6,0	1/4"	6	3/8-19	41,5	17,5	22,0
1214200	H1220841-050400	Crimped	5	8,0	5/16"	4	1/4-19	19,0	17,5	19,0
1202343	H1220843-050600	Slip on nut	5	8,0	5/16"	6	3/8-19	45,1	18,5	22,0
1202344	H1220843-060600	Slip on nut	6	10,0	3/8"	6	3/8-19	49,9	20,5	22,0
1202345	H1220843-060800	Slip on nut	6	10,0	3/8"	8	1/2-14	45,7	21,0	27,0
1202346	H1220843-080800	Slip on nut	8	13,0	1/2"	8	1/2-14	55,0	21,0	27,0
1202347	H1220843-081000	Slip on nut	8	13,0	1/2"	10	5/8-14	57,2	23,0	27,0
1202348	H1220843-081200	Slip on nut	8	13,0	1/2"	12	3/4-14	56,7	23,0	32,0
1202464	H1220841-101000	Crimped	10	16,0	5/8"	10	5/8-14	64,0	21,5	27,0
1202349	H1220843-101200	Slip on nut	10	16,0	5/8"	12	3/4-14	66,5	22,5	32,0
1202465	H1220841-121200	Crimped	12	19,0	3/4"	12	3/4-14	70,0	28,0	32,0
1202350	H1220843-121600	Slip on nut	12	19,0	3/4"	16	1-11	74,6	31,5	38,0
1202466	H1220841-161600	Crimped	16	25,0	1"	16	1-11	84,0	34,0	38,0
1216663	H1220843-162000	Slip on nut	16	25,0	1"	20	1 1/4-11	97,0	47,5	50,0
1202467	H1220842-202000	Slip on nut	20	32,0	1 1/4"	20	1 1/4-11	101,0	40,0	50,0
1202468	H1220842-242400	Thrust wire nut	24	38,0	1 1/2"	24	1 1/2-11	116,0	46,0	55,0
1202469	H1220842-323200	Thrust wire nut	32	51,0	2"	32	2-11	152,0	60,0	70,0

Image: insert with Slip on Nut.

REV.2.1

// H1220893

90° BSPP Female 60° Cone with O-Ring

DKOR 90

Solid one piece

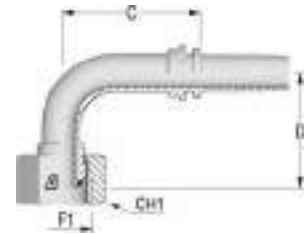

Item Code	Product Code	Nut Type	ID (Dash)	ID (mm)	ID (in)	F1 Dash	F1	C (mm)	D Drop (mm)	CH1 (mm)
1200607	H1220591-030200	Crimped	3	5,0	3/16"	2	1/8-28	24,0	30,0	14,0
1201707	H1220591-040200	Crimped	4	6,0	1/4"	2	1/8-28	30,5	32,0	14,0
1202367	H1220893-040400	Slip on nut	4	6,0	1/4"	4	1/4-19	29,3	29,0	19,0
1202353	H1220893-040600	Slip on nut	4	6,0	1/4"	6	3/8-19	29,8	31,0	22,0
1202354	H1220893-050600	Slip on nut	5	8,0	5/16"	6	3/8-19	33,2	36,0	22,0
1202355	H1220893-060600	Slip on nut	6	10,0	3/8"	6	3/8-19	34,8	42,0	22,0
1202356	H1220893-060800	Slip on nut	6	10,0	3/8"	8	1/2-14	34,3	35,5	27,0
1202881	H1220891-080600	Crimped	8	13,0	1/2"	6	3/8-19	35,3	43,0	22,0
1202357	H1220893-080800	Slip on nut	8	13,0	1/2"	8	1/2-14	35,8	41,0	27,0
1202358	H1220893-081000	Slip on nut	8	13,0	1/2"	10	5/8-14	41,6	43,5	27,0
1202359	H1220893-081200	Slip on nut	8	13,0	1/2"	12	3/4-14	41,8	43,0	32,0
1202470	H1220891-101000	Crimped	10	16,0	5/8"	10	5/8-14	47,9	47,0	27,0
1202360	H1220893-101200	Slip on nut	10	16,0	5/8"	12	3/4-14	51,9	49,0	32,0
1202471	H1220891-121200	Crimped	12	19,0	3/4"	12	3/4-14	49,1	53,0	32,0
1202361	H1220893-121600	Slip on nut	12	19,0	3/4"	16	1-11	54,1	60,5	38,0
1202475	H1220891-161600	Crimped	16	25,0	1"	16	1-11	75,1	69,0	38,0
1202362	H1220893-162000	Slip on nut	16	25,0	1"	20	1 1/4-11	75,1	88,5	50,0
1202472	H1220892-202000	Slip on nut	20	32,0	1 1/4"	20	1 1/4-11	82,0	83,0	50,0
1202363	H1220893-202400	Slip on nut	20	32,0	1 1/4"	24	1 1/2-11	101,0	83,0	55,0
1202456	H1220892-242400	Thrust wire nut	24	38,0	1 1/2"	24	1 1/2-11	96,0	96,0	55,0
1202364	H1220893-243200	Slip on nut	24	38,0	1 1/2"	32	2-11	107,8	104,0	70,0
1202473	H1220892-323200	Thrust wire nut	32	51,0	2"	32	2-11	128,0	136,0	70,0

Image: insert with Slip on Nut.

// H1220581

90° Compact BSPP Female 60° Cone

DKR 90

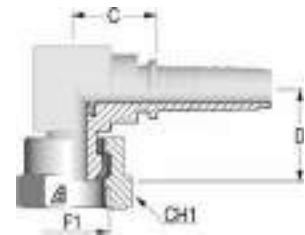

Item Code	Product Code	Nut Type	ID (Dash)	ID (mm)	ID (in)	F1 Dash	F1	C (mm)	D Drop (mm)	CH1 (mm)
1202422	H1220581-040400	Crimped	4	6,0	1/4"	4	1/4-19	16,8	19,5	19,0
1202025	H1220581-060600	Crimped	6	10,0	3/8"	6	3/8-19	18,8	22,0	22,0
1202026	H1220581-060800	Crimped	6	10,0	3/8"	8	1/2-14	21,5	22,5	27,0
1202027	H1220581-080800	Crimped	8	13,0	1/2"	8	1/2-14	22,6	24,5	27,0
1203213	H1220581-121200	Crimped	12	19,0	3/4"	12	3/4-14	26,7	31,0	32,0
1203330	H1220581-161600	Crimped	16	25,0	1"	16	1-11	34,5	27,5	38,0

// H1220613
BSPF Female Flat Seat
DKR FD

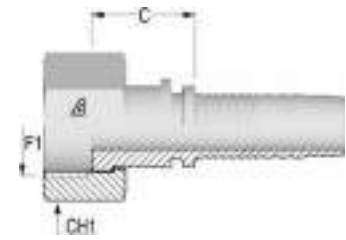

Item Code	Product Code	Nut Type	ID (Dash)	ID (mm)	ID (in)	F1 Dash	F1	C (mm)	CH1 (mm)
1202226	H1220613-040400	Slip on nut	4	6,0	1/4"	4	1/4-19	20,3	19,0
1202227	H1220613-060600	Slip on nut	6	10,0	3/8"	6	3/8-19	20,3	22,0
1202140	H1220613-060800	Slip on nut	6	10,0	3/8"	8	1/2-14	20,8	27,0
1202228	H1220613-080800	Slip on nut	8	13,0	1/2"	8	1/2-14	21,6	27,0
1202229	H1220613-081200	Slip on nut	8	13,0	1/2"	12	3/4-14	24,6	32,0
1201684	H1220611-101200	Crimped	10	16,0	5/8"	12	3/4-14	17,6	32,0
1201570	H1220611-121200	Crimped	12	19,0	3/4"	12	3/4-14	18,1	32,0
1216659	H1220611-121600	Crimped	12	19,0	3/4"	16	1-11	20,6	38,0
1201384	H1220611-161600	Crimped	16	25,0	1"	16	1-11	19,9	38,0

Image: insert with Slip on Nut.

// H1230310
BSPF Banjo - RNR

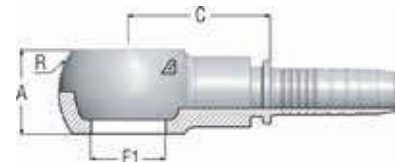

Item Code	Product Code	ID (Dash)	ID (mm)	ID (in)	F1	C (mm)	R (mm)	A (mm)
1203086	H1230310-040400	4	6,0	1/4"	1/4-19	26,5	22	14
1203087	H1230310-040200	4	6,0	1/4"	1/8-28	20,0	17	10
1216840	H1230310-040600	4	6,0	1/4"	3/8-19	30,5	28	18
1201763	H1230310-050600	5	8,0	5/16"	3/8-19	30,5	28	18
1201754	H1230310-060800	6	10,0	3/8"	1/2-14	34,5	38	22
1201760	H1230310-060600	6	10,0	3/8"	3/8-19	30,5	28	18
1203048	H1230310-080800	8	13,0	1/2"	1/2-14	35,0	38	22
1216843	H1230310-080600	8	13,0	1/2"	3/8-19	30,5	28	18
1203085	H1230310-101000	10	16,0	5/8"	5/8-14	38,0	40	24
1200423	H1230310-121200	12	19,0	3/4"	3/4-14	41,5	46	29
1203084	H1230310-161600	16	25,0	1"	1-11	50,5	58	36

REV.2.1

// H10V0210

BSP Bolt

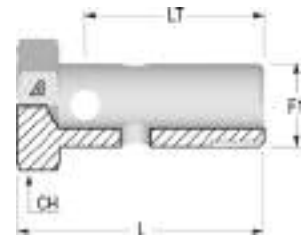

Item Code	Product Code	F1 Dash	F1	LT (mm)	L1 (mm)	CH (mm)
1210366	H10V0210-040000	4	1/4-19	25	30,0	19,0
1210367	H10V0210-060000	6	3/8-19	31	38,0	22,0
1210365	H10V0210-080000	8	1/2-14	38	46,0	27,0
1210404	H10V0210-100000	10	5/8-14	42	51,0	28,0
1210403	H10V0210-120000	12	3/4-14	47	56,0	32,0
1210402	H10V0210-160000	16	1-11	58	69,0	38,0

// DIN METRIC INSERTS

// H1211110

Metric Male 24° Seat
DIN 3853 - Light Series
CEL

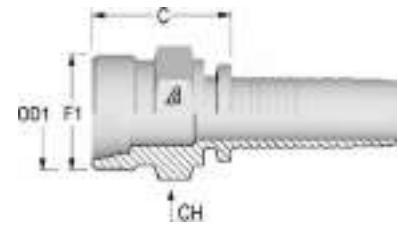

Item Code	Product Code	ID (Dash)	ID (mm)	ID (in)	F1	OD1	C (mm)	CH (mm)
1200451	H1211110-031200	3	5,0	3/16"	M12X1.5	6	20,8	14,0
1200481	H1211110-041200	4	6,0	1/4"	M12X1.5	6	21,3	14,0
1200482	H1211110-041400	4	6,0	1/4"	M14X1.5	8	21,3	14,0
1201558	H1211110-041600	4	6,0	1/4"	M16X1.5	10	23,3	17,0
1200518	H1211110-051600	5	8,0	5/16"	M16X1.5	10	23,3	17,0
1201086	H1211110-051800	5	8,0	5/16"	M18X1.5	12	24,3	19,0
1200314	H1211110-061600	6	10,0	3/8"	M16X1.5	10	23,3	17,0
1200315	H1211110-061800	6	10,0	3/8"	M18X1.5	12	24,3	19,0
1200320	H1211110-062200	6	10,0	3/8"	M22X1.5	15	25,3	22,0
1202565	H1211110-081800	8	13,0	1/2"	M18X1.5	12	25,1	19,0
1200358	H1211110-082200	8	13,0	1/2"	M22X1.5	15	26,1	22,0
1200362	H1211110-082600	8	13,0	1/2"	M26X1.5	18	27,1	27,0
1200401	H1211110-102600	10	16,0	5/8"	M26X1.5	18	27,1	27,0
1200432	H1211110-123000	12	19,0	3/4"	M30X2	22	31,6	32,0
1201372	H1211110-163600	16	25,0	1"	M36X2	28	34,4	36,0
1201373	H1211110-204500	20	32,0	1 1/4"	M45X2	35	40,0	46,0
1201374	H1211110-245200	24	38,0	1 1/2"	M52X2	42	42,0	55,0

REV.2.1

// H1221513

Metric Female 24° Cone with O-Ring
DIN 3865 - Light Series
DKOL

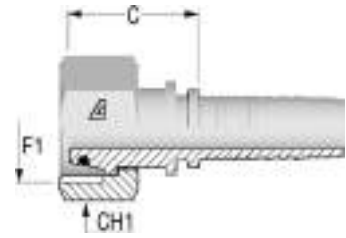

Item Code	Product Code	Nut Type	ID (Dash)	ID (mm)	ID (in)	F1	OD1	C (mm)	CH1 (mm)
1200595	H1221513-031200	Slip on nut	3	5,0	3/16"	M12X1.5	6	23,9	14,0
1202944	H1221511-041200	Crimped	4	6,0	1/4"	M12X1.5	6	24,8	14,0
1200614	H1221513-041400	Slip on nut	4	6,0	1/4"	M14X1.5	8	24,4	17,0
1200609	H1221513-041600	Slip on nut	4	6,0	1/4"	M16X1.5	10	25,4	19,0
1201060	H1221513-041800	Slip on nut	4	6,0	1/4"	M18X1.5	12	25,4	22,0
1238160	H1221512-051400	Thrust wire nut	5	8,0	5/16"	M14X1.5	8	47,7	17,0
1200642	H1221513-051600	Slip on nut	5	8,0	5/16"	M16X1.5	10	25,4	19,0
1200643	H1221513-051800	Slip on nut	5	8,0	5/16"	M18X1.5	12	25,4	22,0
1246243	H1221511-061600	Crimped	6	10,0	3/8"	M16X1.5	3/8"	23,4	19,0
1200667	H1221513-061800	Slip on nut	6	10,0	3/8"	M18X1.5	12	25,4	22,0
1200670	H1221513-062200	Slip on nut	6	10,0	3/8"	M22X1.5	15	27,4	27,0
1238162	H1221512-081800	Thrust wire nut	8	13,0	1/2"	M18X1.5	12	24,0	22,0
1200707	H1221513-082200	Slip on nut	8	13,0	1/2"	M22X1.5	15	28,2	27,0
1201843	H1221513-082600	Slip on nut	8	13,0	1/2"	M26X1.5	18	29,2	32,0
1238163	H1221512-102200	Thrust wire nut	10	16,0	5/8"	M22X1.5	15	25,3	27,0
1200736	H1221513-102600	Slip on nut	10	16,0	5/8"	M26X1.5	18	29,2	32,0
1239646	H1221512-122600	Thrust wire nut	12	19,0	3/4"	M26X1.5	18	25,5	32,0
1200762	H1221513-123000	Slip on nut	12	19,0	3/4"	M30X2	22	31,7	36,0
1220609	H1221513-123600	Slip on nut	12	19,0	3/4"	M36X2	28	32,8	41,0
1201593	H1221512-163000	Thrust wire nut	16	25,0	1"	M30X2	22	44,6	36,0
1201385	H1221513-163600	Slip on nut	16	25,0	1"	M36X2	28	33,6	41,0
1225980	H1221513-164500	Slip on nut	16	25,0	1"	M45X2	35	38,5	50,0
1201386	H1221513-204500	Slip on nut	20	32,0	1 1/4"	M45X2	35	40,1	50,0
1201387	H1221513-245200	Slip on nut	24	38,0	1 1/2"	M52X2	42	40,5	60,0

Image: insert with Slip on Nut.

// H1221543

45° Metric Female 24° Cone with O-Ring

DIN 3865 - Light Series

DKOL 45

Solid one piece

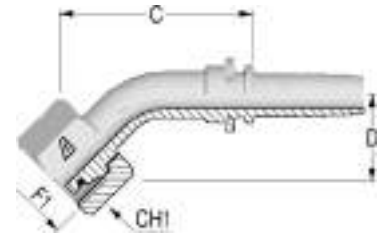

Item Code	Product Code	Nut Type	ID (Dash)	ID (mm)	ID (in)	F1	OD1	C (mm)	D Drop (mm)	CH1 (mm)
1200594	H1221543-031200	Slip on nut	3	5,0	3/16"	M12X1.5	6	44,9	19,0	14,0
1216676	H1221541-041200	Crimped	4	6,0	1/4"	M12X1.5	6	45,2	15,5	14,0
1200612	H1221543-041400	Slip on nut	4	6,0	1/4"	M14X1.5	8	43,0	17,5	17,0
1201576	H1221543-041600	Slip on nut	4	6,0	1/4"	M16X1.5	10	42,0	20,0	19,0
1200645	H1221543-051600	Slip on nut	5	8,0	5/16"	M16X1.5	10	47,5	20,0	19,0
1200646	H1221543-051800	Slip on nut	5	8,0	5/16"	M18X1.5	12	47,0	22,0	22,0
1200671	H1221543-061800	Slip on nut	6	10,0	3/8"	M18X1.5	12	46,8	19,5	22,0
1239971	H1221542-081800	Thrust wire nut	8	13,0	1/2"	M18X1.5	12	52,0	23,0	22,0
1200711	H1221543-082200	Slip on nut	8	13,0	1/2"	M22X1.5	15	55,0	21,0	27,0
1200738	H1221543-102600	Slip on nut	10	16,0	5/8"	M26X1.5	18	65,3	24,0	32,0
1240723	H1221542-122600	Thrust wire nut	12	19,0	3/4"	M26X1.5	20	77,0	34,0	32,0
1200764	H1221543-123000	Slip on nut	12	19,0	3/4"	M30X2	22	69,4	32,0	36,0
1225983	H1221542-163000	Thrust wire nut	16	25,0	1"	M30X2	22	71,1	29,0	36,0
1201390	H1221543-163600	Slip on nut	16	25,0	1"	M36X2	28	91,4	32,0	41,0
1201392	H1221543-204500	Slip on nut	20	32,0	1 1/4"	M45X2	35	100,0	45,0	50,0
1202128	H1221543-245200	Slip on nut	24	38,0	1 1/2"	M52X2	42	114,1	47,0	60,0

Image: insert with Slip on Nut.

REV.2.1

// H1221593

90° Metric Female 24° Cone with O-Ring

DIN 3865 - Light Series

DKOL 90

Solid one piece

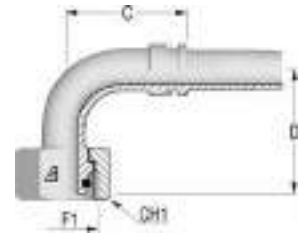

Item Code	Product Code	Nut Type	ID (Dash)	ID (mm)	ID (in)	F1	OD1	C (mm)	D Drop (mm)	CH1 (mm)
1200597	H1221593-031200	Slip on nut	3	5,0	3/16"	M12X1.5	6	23,6	33,0	14,0
1203240	H1221591-041200	Crimped	4	6,0	1/4"	M12X1.5	6	29,5	26,0	14,0
1200618	H1221593-041400	Slip on nut	4	6,0	1/4"	M14X1.5	8	28,3	32,5	17,0
1200616	H1221593-041600	Slip on nut	4	6,0	1/4"	M16X1.5	10	28,3	32,5	19,0
1203218	H1221593-041800	Slip on nut	4	6,0	1/4"	M18X1.5	12	28,8	35,0	22,0
1200648	H1221593-051600	Slip on nut	5	8,0	5/16"	M16X1.5	10	33,7	38,0	19,0
1200649	H1221593-051800	Slip on nut	5	8,0	5/16"	M18X1.5	12	32,2	40,0	22,0
1246244	H1221591-061600	Crimped	6	10,0	3/8"	M16X1.5	10	36,0	36,0	19,0
1200676	H1221593-061800	Slip on nut	6	10,0	3/8"	M18X1.5	12	32,8	39,0	22,0
1200679	H1221593-062200	Slip on nut	6	10,0	3/8"	M22X1.5	15	35,8	38,5	27,0
1238173	H1221592-081800	Thrust wire nut	8	13,0	1/2"	M18X1.5	12	42,0	44,0	22,0
1200713	H1221593-082200	Slip on nut	8	13,0	1/2"	M22X1.5	15	39,8	40,5	27,0
1203154	H1221593-082600	Slip on nut	8	13,0	1/2"	M26X1.5	18	39,8	41,0	32,0
1201292	H1221593-1022B0	Slip on nut	10	16,0	5/8"	M22X1.5	15	51,4	47,0	27,0
1200740	H1221593-102600	Slip on nut	10	16,0	5/8"	M26X1.5	18	51,4	48,0	32,0
1200742	H1221593-103000	Slip on nut	10	16,0	5/8"	M30X2	22	52,4	49,0	36,0
1239736	H1221592-122600	Thrust wire nut	12	19,0	3/4"	M26X1.5	18	60,0	64,0	32,0
1200767	H1221593-123000	Slip on nut	12	19,0	3/4"	M30X2	22	52,1	59,0	36,0
1216685	H1221593-123600	Slip on nut	12	19,0	3/4"	M36X2	28	60,0	63,0	41,0
1225987	H1221592-163000	Thrust wire nut	16	25,0	1"	M30X2	22	66,0	64,0	36,0
1201391	H1221593-163600	Slip on nut	16	25,0	1"	M36X2	28	75,0	68,0	41,0
1216679	H1221592-203600	Thrust wire nut	20	32,0	1 1/4"	M36X2	28	92,2	86,0	41,0
1201393	H1221593-204500	Slip on nut	20	32,0	1 1/4"	M45X2	35	90,5	89,0	50,0
1201394	H1221593-245200	Slip on nut	24	38,0	1 1/2"	M52X2	42	106,5	97,5	60,0

Image: insert with Slip on Nut.

// H1211210

Metric Male 24° Seat
DIN 3853 - Heavy Series
CES

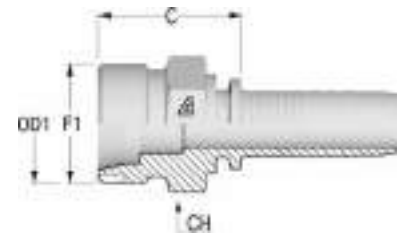

Item Code	Product Code	ID (Dash)	ID (mm)	ID (in)	F1	OD1	C (mm)	CH (mm)
1201828	H1211210-041400	4	6,0	1/4"	M14X1.5	6	24,3	17,0
1200485	H1211210-041600	4	6,0	1/4"	M16X1.5	8	24,3	17,0
1200477	H1211210-041800	4	6,0	1/4"	M18X1.5	10	25,3	19,0
1200521	H1211210-052000	5	8,0	5/16"	M20X1.5	12	25,3	22,0
1202267	H1211210-061800	6	10,0	3/8"	M18X1.5	10	25,3	19,0
1200316	H1211210-062000	6	10,0	3/8"	M20X1.5	12	25,3	22,0
1200319	H1211210-062200	6	10,0	3/8"	M22X1.5	14	27,3	22,0
1221728	H1211210-062400	6	10,0	3/8"	M24X1.5	16	28,1	24,0
1202564	H1211210-082200	8	13,0	1/2"	M22X1.5	14	28,1	22,0
1200360	H1211210-082400	8	13,0	1/2"	M24X1.5	16	29,1	24,0
1200364	H1211210-083000	8	13,0	1/2"	M30X2	20	33,1	32,0
1200403	H1211210-103000	10	16,0	5/8"	M30X2	20	33,1	32,0
1202526	H1211210-123000	12	19,0	3/4"	M30X2	20	33,6	32,0
1200434	H1211210-123600	12	19,0	3/4"	M36X2	25	37,6	36,0
1203151	H1211210-163600	16	25,0	1"	M36X2	25	38,4	36,0
1201375	H1211210-164200	16	25,0	1"	M42X2	30	42,4	46,0
1201376	H1211210-205200	20	32,0	1 1/4"	M52X2	38	48,0	55,0

REV.2.1

// H1221613

Metric Female 24° Cone with O-Ring
DIN 3865 - Heavy Series
DKOS

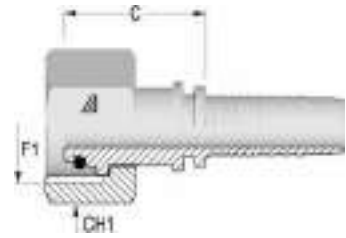

Item Code	Product Code	Nut Type	ID (Dash)	ID (mm)	ID (in)	F1	OD1	C (mm)	CH1 (mm)
1200596	H1221613-031600	Slip on nut	3	5,0	3/16"	M16X1.5	8	27,2	19,0
1201827	H1221613-041400	Slip on nut	4	6,0	1/4"	M14X1.5	6	26,4	17,0
1200615	H1221613-041600	Slip on nut	4	6,0	1/4"	M16X1.5	8	27,7	19,0
1200610	H1221613-041800	Slip on nut	4	6,0	1/4"	M18X1.5	10	27,6	22,0
1201061	H1221613-042000	Slip on nut	4	6,0	1/4"	M20X1.5	12	27,6	24,0
1201832	H1221613-051800	Slip on nut	5	8,0	5/16"	M18X1.5	10	27,6	22,0
1200644	H1221613-052000	Slip on nut	5	8,0	5/16"	M20X1.5	12	27,6	24,0
1239671	H1221612-061600	Thrust wire nut	6	10,0	3/8"	M16X1.5	8	23,2	19,0
1238179	H1221612-061800	Thrust wire nut	6	10,0	3/8"	M18X1.5	10	22,3	22,0
1200668	H1221613-062000	Slip on nut	6	10,0	3/8"	M20X1.5	12	27,6	24,0
1200669	H1221613-062200	Slip on nut	6	10,0	3/8"	M22X1.5	14	31,1	27,0
1202570	H1221613-062400	Slip on nut	6	10,0	3/8"	M24X1.5	16	30,9	30,0
1239650	H1221612-082000	Thrust wire nut	8	13,0	1/2"	M20X1.5	12	23,2	24,0
1218557	H1221613-082200	Slip on nut	8	13,0	1/2"	M22X1.5	14	31,9	27,0
1200708	H1221613-082400	Slip on nut	8	13,0	1/2"	M24X1.5	16	31,7	30,0
1200710	H1221613-083000	Slip on nut	8	13,0	1/2"	M30X2	20	36,5	36,0
1200737	H1221613-103000	Slip on nut	10	16,0	5/8"	M30X2	20	36,5	36,0
1201732	H1221613-123000	Slip on nut	12	19,0	3/4"	M30X2	20	37,0	36,0
1200763	H1221613-123600	Slip on nut	12	19,0	3/4"	M36X2	25	40,2	46,0
1239744	H1221612-163000	Thrust wire nut	16	25,0	1"	M30X2	20	29,8	36,0
1203099	H1221613-163600	Slip on nut	16	25,0	1"	M36X2	25	41,0	46,0
1201388	H1221613-164200	Slip on nut	16	25,0	1"	M42X2	30	43,1	50,0
1216693	H1221613-204200	Slip on nut	20	32,0	1 1/4"	M42X2	30	44,7	50,0
1201389	H1221613-205200	Slip on nut	20	32,0	1 1/4"	M52X2	38	48,1	60,0
1216695	H1221613-245200	Slip on nut	24	38,0	1 1/2"	M52X2	38	48,1	60,0

Image: insert with Slip on Nut.

// H1221643

45° Metric Female 24° Cone with O-Ring

DIN 3865 - Heavy Series

DKOS 45

Solid one piece

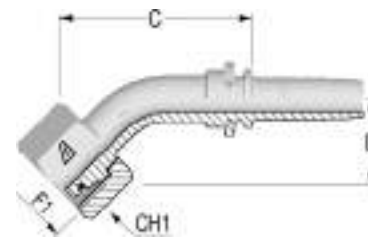

Item Code	Product Code	Nut Type	ID (Dash)	ID (mm)	ID (in)	F1	OD1	C (mm)	D Drop (mm)	CH1 (mm)
1216697	H1221643-041400	Slip on nut	4	6,0	1/4"	M14X1.5	6	47,0	20,0	17,0
1200613	H1221643-041600	Slip on nut	4	6,0	1/4"	M16X1.5	8	48,6	16,0	19,0
1200611	H1221643-041800	Slip on nut	4	6,0	1/4"	M18X1.5	10	43,5	19,0	22,0
1240698	H1221643-051800	Slip on nut	5	8,0	5/16"	M18X1.5	10	46,0	18,0	22,0
1200647	H1221643-052000	Slip on nut	5	8,0	5/16"	M20X1.5	12	48,1	21,0	24,0
1239968	H1221642-061800	Thrust wire nut	6	10,0	3/8"	M18X1.5	10	47,0	21,0	22,0
1200672	H1221643-062000	Slip on nut	6	10,0	3/8"	M20X1.5	12	50,6	20,0	24,0
1200673	H1221643-062200	Slip on nut	6	10,0	3/8"	M22X1.5	14	52,9	21,0	27,0
1242602	H1221642-082000	Thrust wire nut	8	13,0	1/2"	M20X1.5	12	54,0	24,0	24,0
1200712	H1221643-082400	Slip on nut	8	13,0	1/2"	M24X1.5	16	55,8	21,5	30,0
1201300	H1221643-103000	Slip on nut	10	16,0	5/8"	M30X2	20	66,3	30,0	36,0
1202891	H1221643-123000	Slip on nut	12	19,0	3/4"	M30X2	20	66,1	29,0	36,0
1200765	H1221643-123600	Slip on nut	12	19,0	3/4"	M36X2	25	69,5	33,0	46,0
1203098	H1221643-163600	Slip on nut	16	25,0	1"	M36X2	25	89,7	36,0	46,0
1201395	H1221643-164200	Slip on nut	16	25,0	1"	M42X2	30	110,3	40,5	50,0
1201398	H1221643-205200	Slip on nut	20	32,0	1 1/4"	M52X2	38	109,0	45,0	60,0

Image: insert with Slip on Nut.

// H1221693

90° Metric Female 24° Cone with O-Ring

DIN 3865 - Heavy Series

DKOS 90

Solid one piece

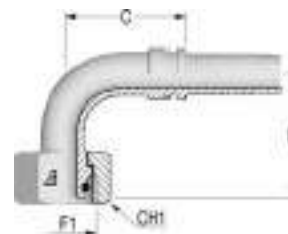

Item Code	Product Code	Nut Type	ID (Dash)	ID (mm)	ID (in)	F1	OD1	C (mm)	D Drop (mm)	CH1 (mm)
1201065	H1221693-041400	Slip on nut	4	6,0	1/4"	M14X1.5	6	27,3	33,0	17,0
1200619	H1221693-041600	Slip on nut	4	6,0	1/4"	M16X1.5	8	27,3	33,0	19,0
1200617	H1221693-041800	Slip on nut	4	6,0	1/4"	M18X1.5	10	26,8	34,0	22,0
1216700	H1221693-051800	Slip on nut	5	8,0	5/16"	M18X1.5	10	33,2	39,0	22,0
1200650	H1221693-052000	Slip on nut	5	8,0	5/16"	M20X1.5	12	33,2	39,0	24,0
1239989	H1221692-061600	Thrust wire nut	6	10,0	3/8"	M16X1.5	8	33,0	38,0	19,0
1239926	H1221692-061800	Thrust wire nut	6	10,0	3/8"	M18X1.5	10	35,0	38,0	22,0
1200677	H1221693-062000	Slip on nut	6	10,0	3/8"	M20X1.5	12	34,3	38,5	24,0
1200678	H1221693-062200	Slip on nut	6	10,0	3/8"	M22X1.5	14	34,3	40,5	27,0
1240110	H1221692-082000	Thrust wire nut	8	13,0	1/2"	M20X1.5	12	40,0	45,0	24,0
1200714	H1221693-082400	Slip on nut	8	13,0	1/2"	M24X1.5	16	39,8	41,5	30,0
1201253	H1221693-083000	Slip on nut	8	13,0	1/2"	M30X2	20	45,8	50,0	36,0
1240088	H1221692-102400	Thrust wire nut	10	16,0	5/8"	M24X1.5	16	52,0	56,0	30,0
1200741	H1221693-103000	Slip on nut	10	16,0	5/8"	M30X2	20	47,9	55,0	36,0
1200766	H1221693-123000	Slip on nut	12	19,0	3/4"	M30X2	20	50,6	58,0	36,0
1200768	H1221693-123600	Slip on nut	12	19,0	3/4"	M36X2	25	50,6	59,5	46,0
1203097	H1221693-163600	Slip on nut	16	25,0	1"	M36X2	25	77,6	73,5	46,0
1201396	H1221693-164200	Slip on nut	16	25,0	1"	M42X2	30	75,6	79,0	50,0
1203096	H1221693-204200	Slip on nut	20	32,0	1 1/4"	M42X2	30	95,0	88,0	50,0
1201397	H1221693-205200	Slip on nut	20	32,0	1 1/4"	M52X2	38	94,0	92,0	60,0

Image: insert with Slip on Nut.

REV.2.1

// H1221313

Universal Metric Female

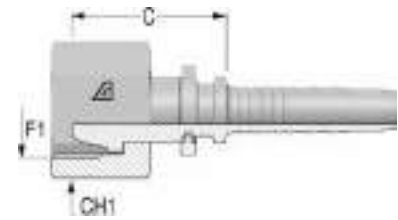

Item Code	Product Code	Nut Type	ID (Dash)	ID (mm)	ID (in)	F1 Dash	F1	C (mm)	CH1 (mm)
1200631	H1221313-041400	Slip on nut	4	6,0	1/4"	14	M14X1.5	22,3	17,0
1200632	H1221313-041600	Slip on nut	4	6,0	1/4"	16	M16X1.5	22,3	19,0
1200633	H1221313-041800	Slip on nut	4	6,0	1/4"	18	M18X1.5	22,3	22,0
1200658	H1221313-051600	Slip on nut	5	8,0	5/16"	16	M16X1.5	22,3	19,0
1200659	H1221313-051800	Slip on nut	5	8,0	5/16"	18	M18X1.5	22,3	22,0
1200698	H1221313-061800	Slip on nut	6	10,0	3/8"	18	M18X1.5	22,3	22,0
1200729	H1221313-082200	Slip on nut	8	13,0	1/2"	22	M22X1.5	24,7	27,0
1200753	H1221313-102600	Slip on nut	10	16,0	5/8"	26	M26X1.5	25,1	32,0

// H1221343

45° Universal Metric Female

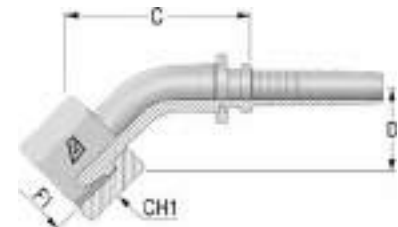

Item Code	Product Code	Nut Type	ID (Dash)	ID (mm)	ID (in)	F1 Dash	F1	C (mm)	D Drop (mm)	CH1 (mm)
1216669	H1221343-041400	Slip on nut	4	6,0	1/4"	14	M14X1.5	36,5	16,0	17,0
1200660	H1221343-051600	Slip on nut	5	8,0	5/16"	16	M16X1.5	42,1	19,0	19,0
1201450	H1221343-061800	Slip on nut	6	10,0	3/8"	18	M18X1.5	42,8	20,0	22,0
1225972	H1221343-082200	Slip on nut	8	13,0	1/2"	22	M22X1.5	54,9	20,0	27,0
1225973	H1221343-102600	Slip on nut	10	16,0	5/8"	26	M26X1.5	54,0	22,0	32,0

// H1221393

90° Universal Metric Female



Item Code	Product Code	Nut Type	ID (Dash)	ID (mm)	ID (in)	F1 Dash	F1	C (mm)	D Drop (mm)	CH1 (mm)
1225975	H1221393-041400	Slip on nut	4	6,0	1/4"	14	M14X1.5	29,9	28,5	17,0
1201452	H1221393-041600	Slip on nut	4	6,0	1/4"	16	M16X1.5	28,3	33,0	19,0
1200661	H1221393-051600	Slip on nut	5	8,0	5/16"	16	M16X1.5	34,2	36,0	19,0
1201323	H1221393-051800	Slip on nut	5	8,0	5/16"	18	M18X1.5	34,0	32,0	22,0
1200701	H1221393-061800	Slip on nut	6	10,0	3/8"	18	M18X1.5	32,8	37,0	22,0
1201580	H1221393-062200	Slip on nut	6	10,0	3/8"	22	M22X1.5	32,3	36,0	27,0
1200730	H1221393-082200	Slip on nut	8	13,0	1/2"	22	M22X1.5	39,8	40,0	27,0
1216672	H1221393-102600	Slip on nut	10	16,0	5/8"	26	M26X1.5	51,0	46,0	32,0

// H1221013

**Metric Female 60° Cone
DIN 3863**

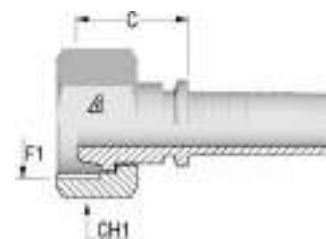

Item Code	Product Code	Nut Type	ID (Dash)	ID (mm)	ID (in)	F1 Dash	F1	C (mm)	CH1 (mm)
1200759	H1221013-123000	Slip on nut	12	19,0	3/4"	30	M30X1.5	21,6	36,0
1201572	H1221013-163800	Slip on nut	16	25,0	1"	38	M38X1.5	28,0	46,0

// H1221093

**90° Metric Female 60° Cone
DIN 3863
Solid one piece**

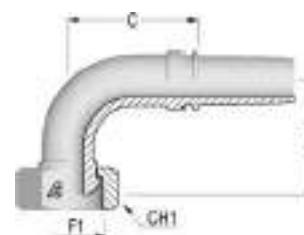

Item Code	Product Code	Nut Type	ID (Dash)	ID (mm)	ID (in)	F1 Dash	F1	C (mm)	D Drop (mm)	CH1 (mm)
1202056	H1221093-123000	Slip on nut	12	19,0	3/4"	30	M30X1.5	54,6	47,0	36,0
1201620	H1221093-163800	Slip on nut	16	25,0	1"	38	M38X1.5	72,6	60,0	46,0

REV.2.1

// H1252010

Metric Straight Standpipe

DIN 2353

RSL/RSS

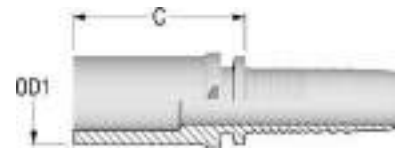

Item Code	Product Code	ID (Dash)	ID (mm)	ID (in)	OD1	C (mm)
1200855	H1252010-030600	3	5,0	3/16"	6	27,8
1200856	H1252010-030800	3	5,0	3/16"	8	29,8
1200859	H1252010-041000	4	6,0	1/4"	10	32,2
1200860	H1252010-041200	4	6,0	1/4"	12	31,2
1200865	H1252010-040600	4	6,0	1/4"	6	28,3
1200867	H1252010-040800	4	6,0	1/4"	8	30,2
1200871	H1252010-051000	5	8,0	5/16"	10	30,2
1200872	H1252010-051200	5	8,0	5/16"	12	32,7
1200878	H1252010-050800	5	8,0	5/16"	8	30,3
1200793	H1252010-061000	6	10,0	3/8"	10	30,3
1200794	H1252010-061200	6	10,0	3/8"	12	29,3
1200796	H1252010-061400	6	10,0	3/8"	14	35,8
1200797	H1252010-061500	6	10,0	3/8"	15	34,8
1216922	H1252010-081000	8	13,0	1/2"	10	32,5
1200809	H1252010-081200	8	13,0	1/2"	12	32,1
1200811	H1252010-081400	8	13,0	1/2"	14	36,1
1200812	H1252010-081500	8	13,0	1/2"	15	32,1
1200813	H1252010-081600	8	13,0	1/2"	16	37,1
1200815	H1252010-081800	8	13,0	1/2"	18	36,0
1200828	H1252010-101800	10	16,0	5/8"	18	34,2
1200829	H1252010-102000	10	16,0	5/8"	20	44,2
1200832	H1252010-102200	10	16,0	5/8"	22	37,2
1200838	H1252010-122000	12	19,0	3/4"	20	45,5
1200840	H1252010-122200	12	19,0	3/4"	22	36,5
1200841	H1252010-122500	12	19,0	3/4"	25	48,5
1201442	H1252010-162500	16	25,0	1"	25	51,4
1201440	H1252010-162800	16	25,0	1"	28	40,4
1201441	H1252010-163000	16	25,0	1"	30	54,4
1214227	H1252010-163800	16	25,0	1"	38	60,4
1214228	H1252010-203000	20	32,0	1 1/4"	30	56,0
1201443	H1252010-203500	20	32,0	1 1/4"	35	48,0
1201444	H1252010-203800	20	32,0	1 1/4"	38	62,0
1203082	H1252010-243800	24	38,0	1 1/2"	38	62,0
1201445	H1252010-244200	24	38,0	1 1/2"	42	52,0

// H1252040

45° Metric Standpipe

DIN 2353 - RSL45/RSS 45

Solid one piece

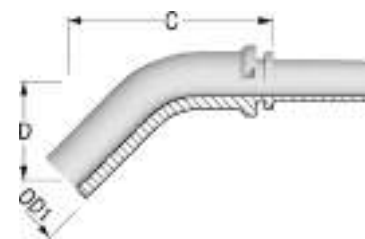

Item Code	Product Code	ID (Dash)	ID (mm)	ID (in)	OD1	C (mm)	D Drop (mm)
1200862	H1252040-041000	4	6,0	1/4"	10	48,0	24,0
1200863	H1252040-040600	4	6,0	1/4"	6	50,1	28,0
1200864	H1252040-040800	4	6,0	1/4"	8	43,2	23,0
1200876	H1252040-051000	5	8,0	5/16"	10	48,4	24,0
1200877	H1252040-051200	5	8,0	5/16"	12	55,4	28,0
1200800	H1252040-061000	6	10,0	3/8"	10	48,5	24,0
1200801	H1252040-061200	6	10,0	3/8"	12	55,5	28,0
1200802	H1252040-061400	6	10,0	3/8"	14	53,1	28,0
1200817	H1252040-081500	8	13,0	1/2"	15	62,6	28,5
1200818	H1252040-081600	8	13,0	1/2"	16	63,3	32,0
1200843	H1252040-122200	12	19,0	3/4"	22	74,3	37,0
1200844	H1252040-122500	12	19,0	3/4"	25	83,0	44,0
1214232	H1252040-163000	16	25,0	1"	30	137,0	46,1

// H1252090

90° Metric Standpipe

DIN 2353 - RSL 90/RSS90

Solid one piece



Item Code	Product Code	ID (Dash)	ID (mm)	ID (in)	OD1	C (mm)	D Drop (mm)
1200857	H1252090-030600	3	5,0	3/16"	6	24,5	36,0
1200868	H1252090-041000	4	6,0	1/4"	10	37,0	42,0
1202296	H1252090-041200	4	6,0	1/4"	12	38,0	50,0
1200869	H1252090-040600	4	6,0	1/4"	6	25,4	36,0
1200870	H1252090-040800	4	6,0	1/4"	8	25,9	44,0
1200879	H1252090-051000	5	8,0	5/16"	10	28,6	48,5
1200880	H1252090-051200	5	8,0	5/16"	12	39,4	55,0
1200803	H1252090-061000	6	10,0	3/8"	10	30,7	42,0
1200804	H1252090-061200	6	10,0	3/8"	12	35,0	50,0
1200805	H1252090-061400	6	10,0	3/8"	14	37,0	50,0
1218454	H1252090-081200	8	13,0	1/2"	12	41,1	52,0
1200822	H1252090-081500	8	13,0	1/2"	15	44,7	57,0
1200823	H1252090-081600	8	13,0	1/2"	16	43,7	64,0
1203079	H1252090-081800	8	13,0	1/2"	18	58,1	59,0
1200835	H1252090-101800	10	16,0	5/8"	18	52,2	58,0
1200836	H1252090-102000	10	16,0	5/8"	20	62,6	70,0
1210832	H1252090-102200	10	16,0	5/8"	22	49,4	64,0
1203081	H1252090-122000	12	19,0	3/4"	20	63,4	70,0
1200846	H1252090-122200	12	19,0	3/4"	22	53,1	67,5
1200847	H1252090-122500	12	19,0	3/4"	25	63,2	85,0
1214233	H1252090-162500	16	25,0	1"	25	73,1	98,5
1202886	H1252090-162800	16	25,0	1"	28	73,1	89,5
1214234	H1252090-163000	16	25,0	1"	30	73,1	102,5
1214235	H1252090-203500	20	32,0	1 1/4"	35	89,0	106,5

REV.2.1

// H1230910

Metric Banjo

RNM

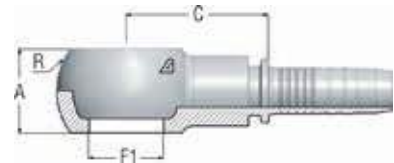

Item Code	Product Code	ID (Dash)	ID (mm)	ID (in)	F1	C (mm)	R (mm)	A (mm)
1202577	H1230910-031000	3	5,0	3/16"	M10X1.0	24,0	17	10
1200468	H1230910-041000	4	6,0	1/4"	M10X1.0	25,0	17	10
1200469	H1230910-041200	4	6,0	1/4"	M12X1.5	28,5	20	12
1200470	H1230910-041400	4	6,0	1/4"	M14X1.5	27,5	24	14
1200513	H1230910-051200	5	8,0	5/16"	M12X1.5	28,5	24	12
1200514	H1230910-051400	5	8,0	5/16"	M14X1.5	27,5	24	14
1200515	H1230910-051600	5	8,0	5/16"	M16X1.5	30,5	28	18
1200516	H1230910-051800	5	8,0	5/16"	M18X1.5	28,5	32	20
1200309	H1230910-061400	6	10,0	3/8"	M14X1.5	27,5	24	14
1200310	H1230910-061600	6	10,0	3/8"	M16X1.5	30,5	28	18
1200311	H1230910-061800	6	10,0	3/8"	M18X1.5	31,5	32	20
1200346	H1230910-081800	8	13,0	1/2"	M18X1.5	32,0	32	20
1200347	H1230910-082200	8	13,0	1/2"	M22X1.5	35,0	39	22
1200389	H1230910-102200	10	16,0	5/8"	M22X1.5	35,0	39	23,5
1200422	H1230910-122600	12	19,0	3/4"	M26X1.5	38,5	46	29
1203083	H1230910-163000	16	25,0	1"	M30X1.5	42,5	54	36

// H10V0810

Metric Bolt

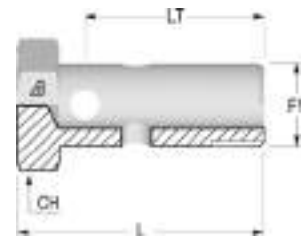

Item Code	Product Code	F1 Dash	F1	LT (mm)	L1 (mm)	CH (mm)
1210374	H10V0810-100000	10	M10X1.0	19	24,0	14,0
1210375	H10V0810-120000	12	M12X1.5	24	29,0	17,0
1210368	H10V0810-140000	14	M14X1.5	28	34,0	19,0
1210384	H10V0810-160000	16	M16X1.5	34	41,0	22,0
1210369	H10V0810-180000	18	M18X1.5	37	44,0	24,0
1210371	H10V0810-220000	22	M22X1.5	41	48,0	27,0
1210406	H10V0810-260000	26	M26X1.5	42	52,0	32,0
1210405	H10V0810-300000	30	M30X1.5	51	62,0	38,0

// PRESSURE WASHER

// H1224914

Universal Female for Pressure Washer

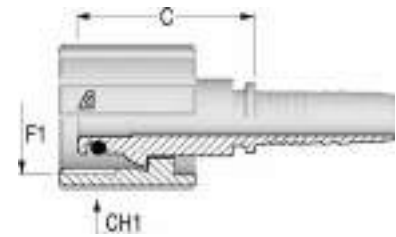

Item Code	Product Code	Nut Type	ID (Dash)	ID (mm)	ID (in)	F1 Dash	F1	C (mm)	CH1 (mm)
1203350	H1224914-042200	Slip on nut	4	6,0	1/4"	22	M22X1.5	36,8	35,0
1203351	H1224914-052200	Slip on nut	5	8,0	5/16"	22	M22X1.5	36,8	35,0
1203352	H1224914-062200	Slip on nut	6	10,0	3/8"	22	M22X1.5	36,8	35,0

REV.2.1

// SAE INSERTS

// H1226611

SAE Female Swivel 45° Seat

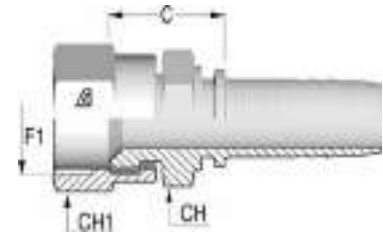

Item Code	Product Code	Nut Type	ID (Dash)	ID (mm)	ID (in)	F1 Dash	F1	C (mm)	CH (mm)	CH1 (mm)
1202661	H1226611-060600	Crimped	6	10,0	3/8"	6	5/8-18	23,3	19,0	22,0
1226098	H1226611-081000	Crimped	8	13,0	1/2"	10	7/8-14	26,6	22,0	27,0
1202371	H1226611-121200	Crimped	12	19,0	3/4"	12	1 1/16-14	28,6	27,0	32,0

// H1213010

SAE Male Solid - O-Ring Boss

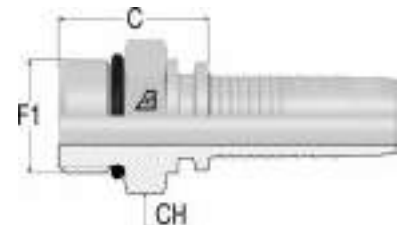

Item Code	Product Code	ID (Dash)	ID (mm)	ID (in)	F1 Dash	F1	C (mm)	CH (mm)
1203147	H1213010-040400	4	6,0	1/4"	4	7/16-20	20,3	14,0
1201833	H1213010-040500	4	6,0	1/4"	5	1/2-20	21,3	16,0
1202519	H1213010-040600	4	6,0	1/4"	6	9/16-18	22,3	17,0
1201834	H1213010-060600	6	10,0	3/8"	6	9/16-18	23,3	19,0
1200337	H1213010-060800	6	10,0	3/8"	8	3/4-16	24,3	22,0
1200338	H1213010-061000	6	10,0	3/8"	10	7/8-14	26,8	27,0
1200382	H1213010-080800	8	13,0	1/2"	8	3/4-16	25,1	22,0
1200383	H1213010-081000	8	13,0	1/2"	10	7/8-14	27,6	27,0
1200381	H1213010-081200	8	13,0	1/2"	12	1 1/16-12	32,1	32,0
1221652	H1213010-101000	10	16,0	5/8"	10	7/8-14	27,6	24,0
1203146	H1213010-121000	12	19,0	3/4"	10	7/8-14	28,1	27,0
1200445	H1213010-121200	12	19,0	3/4"	12	1 1/16-12	32,6	32,0
1201836	H1213010-161600	16	25,0	1"	16	1 5/16-12	35,4	38,0
1225859	H1213010-202000	20	32,0	1 1/4"	20	1 5/8-12	39,0	46,0

// H1213011

SAE Male Swivel - O-Ring Boss

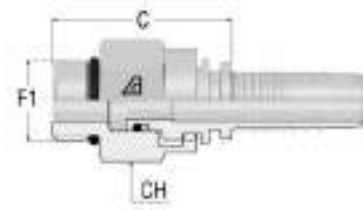

Item Code	Product Code	Nut Type	ID (Dash)	ID (mm)	ID (in)	F1 Dash	F1	C (mm)	CH (mm)
1225927	H1213011-060600	Crimped	6	10,0	3/8"	6	9/16-18	40,5	22,0
1225928	H1213011-060800	Crimped	6	10,0	3/8"	8	3/4-16	22,0	22,0
1225929	H1213011-080800	Crimped	8	13,0	1/2"	8	3/4-16	23,0	25,0
1225930	H1213011-081000	Crimped	8	13,0	1/2"	10	7/8-14	23,0	25,0
1230553	H1213011-121200	Crimped	12	19,0	3/4"	12	1 1/16-12	49,6	32,0

// H1213081

90° Compact SAE Male Swivel - O-Ring Boss

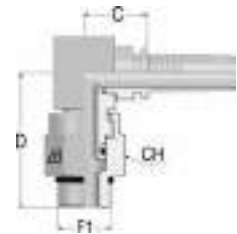

Item Code	Product Code	Nut Type	ID (Dash)	ID (mm)	ID (in)	F1 Dash	F1	C (mm)	D Drop (mm)	CH (mm)
1226490	H1213081-040500	Crimped	4	6,0	1/4"	5	1/2-20	17,0	34,0	17,0
1225933	H1213081-060800	Crimped	6	10,0	3/8"	8	3/4-16	22,0	44,0	25,0
1225934	H1213081-080800	Crimped	8	13,0	1/2"	8	3/4-16	21,6	49,7	25,0
1225935	H1213081-081000	Crimped	8	13,0	1/2"	10	7/8-14	23,0	49,0	25,0
1226492	H1213081-121200	Crimped	12	19,0	3/4"	12	1 1/16-12	27,0	61,0	32,0
1240593	H1213081-161600	Crimped	16	25,0	1"	16	1 5/16-12	34,4	67,5	41,0

REV.2.1

// JIC 37° INSERTS

// H1212510

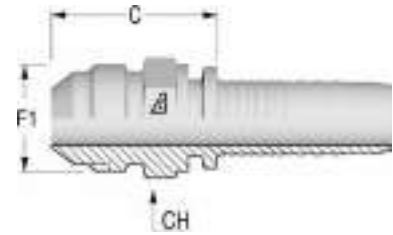
JIC Male 37° Cone
AGJ

Item Code	Product Code	ID (Dash)	ID (mm)	ID (in)	F1 Dash	F1	C (mm)	CH (mm)
1200457	H1212510-030400	3	5,0	3/16"	4	7/16-20	23,8	12,0
1200500	H1212510-040400	4	6,0	1/4"	4	7/16-20	25,3	12,0
1200499	H1212510-040500	4	6,0	1/4"	5	1/2-20	25,3	14,0
1200501	H1212510-040600	4	6,0	1/4"	6	9/16-18	26,3	17,0
1200534	H1212510-050500	5	8,0	5/16"	5	1/2-20	25,3	14,0
1200535	H1212510-050600	5	8,0	5/16"	6	9/16-18	26,3	17,0
1201087	H1212510-050800	5	8,0	5/16"	8	3/4-16	29,8	19,0
1200332	H1212510-060600	6	10,0	3/8"	6	9/16-18	26,3	17,0
1200330	H1212510-060800	6	10,0	3/8"	8	3/4-16	29,8	19,0
1200331	H1212510-061000	6	10,0	3/8"	10	7/8-14	33,8	24,0
1200375	H1212510-080800	8	13,0	1/2"	8	3/4-16	30,6	19,0
1200376	H1212510-081000	8	13,0	1/2"	10	7/8-14	34,6	24,0
1200374	H1212510-081200	8	13,0	1/2"	12	1 1/16-12	37,1	27,0
1200413	H1212510-101000	10	16,0	5/8"	10	7/8-14	34,6	24,0
1200411	H1212510-101200	10	16,0	5/8"	12	1 1/16-12	37,1	27,0
1200441	H1212510-121200	12	19,0	3/4"	12	1 1/16-12	37,6	27,0
1200442	H1212510-121400	12	19,0	3/4"	14	1 3/16-12	40,1	32,0
1200443	H1212510-121600	12	19,0	3/4"	16	1 5/16-12	42,6	36,0
1222989	H1212510-161200	16	25,0	1"	12	1 1/16-12	40,4	32,0
1201379	H1212510-161600	16	25,0	1"	16	1 5/16-12	43,4	36,0
1201380	H1212510-162000	16	25,0	1"	20	1 5/8-12	46,9	46,0
1201381	H1212510-202000	20	32,0	1 1/4"	20	1 5/8-12	48,5	46,0
1201785	H1212510-202400	20	32,0	1 1/4"	24	1 7/8-12	52,5	50,0
1201382	H1212510-242400	24	38,0	1 1/2"	24	1 7/8-12	52,5	50,0
1201383	H1212510-323200	32	51,0	2"	32	2 1/2-12	62,0	65,0

// H1222511

JIC Female 37° Seat

DKJ

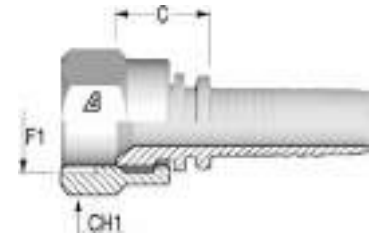

Item Code	Product Code	Nut Type	ID (Dash)	ID (mm)	ID (in)	F1 Dash	F1	C (mm)	CH1 (mm)
1200600	H1222511-030400	Crimped	3	5,0	3/16"	4	7/16-20	14,3	16,0
1200625	H1222511-040400	Crimped	4	6,0	1/4"	4	7/16-20	14,6	16,0
1200623	H1222511-040500	Crimped	4	6,0	1/4"	5	1/2-20	15,3	17,0
1200626	H1222511-040600	Crimped	4	6,0	1/4"	6	9/16-18	15,3	19,0
1200655	H1222511-050500	Crimped	5	8,0	5/16"	5	1/2-20	15,3	17,0
1200656	H1222511-050600	Crimped	5	8,0	5/16"	6	9/16-18	15,3	19,0
1200691	H1222511-060600	Crimped	6	10,0	3/8"	6	9/16-18	15,3	19,0
1200687	H1222511-060800	Crimped	6	10,0	3/8"	8	3/4-16	17,8	25,0
1200690	H1222511-061000	Crimped	6	10,0	3/8"	10	7/8-14	20,3	27,0
1200723	H1222511-080800	Crimped	8	13,0	1/2"	8	3/4-16	18,6	25,0
1200725	H1222511-081000	Crimped	8	13,0	1/2"	10	7/8-14	19,6	27,0
1200722	H1222511-081200	Crimped	8	13,0	1/2"	12	1 1/16-12	22,1	32,0
1200751	H1222511-101000	Crimped	10	16,0	5/8"	10	7/8-14	19,6	27,0
1200749	H1222511-101200	Crimped	10	16,0	5/8"	12	1 1/16-12	20,1	32,0
1201841	H1222511-121000	Crimped	12	19,0	3/4"	10	7/8-14	20,1	27,0
1200774	H1222511-121200	Crimped	12	19,0	3/4"	12	1 1/16-12	20,6	32,0
1200775	H1222511-121400	Crimped	12	19,0	3/4"	14	1 3/16-12	19,9	36,0
1200776	H1222511-121600	Crimped	12	19,0	3/4"	16	1 5/16-12	22,1	38,0
1201399	H1222511-161200	Crimped	16	25,0	1"	12	1 1/16-12	22,4	32,0
1201400	H1222511-161600	Crimped	16	25,0	1"	16	1 5/16-12	23,9	38,0
1201401	H1222512-162000	Thrust wire nut	16	25,0	1"	20	1 5/8-12	26,5	50,0
1202820	H1222511-201600	Crimped	20	32,0	1 1/4"	16	1 5/16-12	26,5	38,0
1201402	H1222512-202000	Thrust wire nut	20	32,0	1 1/4"	20	1 5/8-12	28,1	50,0
1201403	H1222512-202400	Thrust wire nut	20	32,0	1 1/4"	24	1 7/8-12	30,4	55,0
1201097	H1222512-242400	Thrust wire nut	24	38,0	1 1/2"	24	1 7/8-12	29,4	55,0
1201404	H1222512-323200	Thrust wire nut	32	51,0	2"	32	2 1/2-12	32,0	70,0

Image: insert with Crimped Nut.

REV.2.1

// H1226511

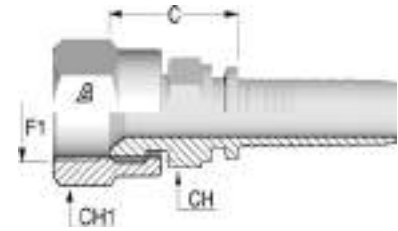
JIC Female 37° Seat with Stem Hexagon
DKJ

Item Code	Product Code	Nut Type	ID (Dash)	ID (mm)	ID (in)	F1 Dash	F1	C (mm)	CH (mm)	CH1 (mm)
1200599	H1226511-030400	Crimped	3	5,0	3/16"	4	7/16-20	18,1	12,0	16,0
1200621	H1226511-040400	Crimped	4	6,0	1/4"	4	7/16-20	18,3	14,0	16,0
1202406	H1226511-040500	Crimped	4	6,0	1/4"	5	1/2-20	20,3	14,0	17,0
1200622	H1226511-040600	Crimped	4	6,0	1/4"	6	9/16-18	20,3	14,0	19,0
1201497	H1226511-050500	Crimped	5	8,0	5/16"	5	1/2-20	20,3	14,0	17,0
1201264	H1226511-050600	Crimped	5	8,0	5/16"	6	9/16-18	20,3	14,0	19,0
1203246	H1226511-060400	Crimped	6	10,0	3/8"	4	7/16-20	20,6	17,0	16,0
1223146	H1226511-060500	Crimped	6	10,0	3/8"	5	1/2-20	21,3	16,0	17,0
1200686	H1226511-060600	Crimped	6	10,0	3/8"	6	9/16-18	21,3	17,0	19,0
1200685	H1226511-060800	Crimped	6	10,0	3/8"	8	3/4-16	24,8	19,0	25,0
1201340	H1226511-061000	Crimped	6	10,0	3/8"	10	7/8-14	25,8	22,0	27,0
1203090	H1226511-080600	Crimped	8	13,0	1/2"	6	9/16-18	23,1	19,0	19,0
1200720	H1226511-080800	Crimped	8	13,0	1/2"	8	3/4-16	25,6	19,0	25,0
1200721	H1226511-081000	Crimped	8	13,0	1/2"	10	7/8-14	26,6	22,0	27,0
1210833	H1226511-081200	Crimped	8	13,0	1/2"	12	1 1/16-12	28,1	25,0	32,0
1203329	H1226511-100800	Crimped	10	16,0	5/8"	8	3/4-16	26,6	24,0	25,0
1201728	H1226511-101000	Crimped	10	16,0	5/8"	10	7/8-14	27,6	24,0	27,0
1201464	H1226511-101200	Crimped	10	16,0	5/8"	12	1 1/16-12	28,1	25,0	32,0
1202895	H1226511-121000	Crimped	12	19,0	3/4"	10	7/8-14	28,1	27,0	27,0
1201333	H1226511-121200	Crimped	12	19,0	3/4"	12	1 1/16-12	28,6	27,0	32,0
1214219	H1226511-121400	Crimped	12	19,0	3/4"	14	1 3/16-12	29,9	32,0	36,0
1203089	H1226511-121600	Crimped	12	19,0	3/4"	16	1 5/16-12	32,1	32,0	38,0
1203243	H1226511-141600	Crimped	14	22,0	7/8"	16	1 5/16-12	32,1	32,0	38,0
1203088	H1226511-161200	Crimped	16	25,0	1"	12	1 1/16-12	31,4	32,0	32,0
1202408	H1226511-161600	Crimped	16	25,0	1"	16	1 5/16-12	32,9	32,0	38,0
1214220	H1226512-162000	Thrust wire nut	16	25,0	1"	20	1 5/8-12	37,5	41,0	50,0
1216812	H1226511-201600	Crimped	20	32,0	1 1/4"	16	1 5/16-12	37,5	41,0	38,0
1202483	H1226512-202000	Thrust wire nut	20	32,0	1 1/4"	20	1 5/8-12	39,1	41,0	50,0
1226093	H1226512-202400	Thrust wire nut	20	32,0	1 1/4"	24	1 7/8-12	43,4	50,0	55,0
1216815	H1226512-242400	Thrust wire nut	24	38,0	1 1/2"	24	1 7/8-12	43,4	50,0	55,0
1216816	H1226512-323200	Thrust wire nut	32	51,0	2"	32	2 1/2-12	49,0	65,0	70,0

Image: insert with Crimped Nut.

// H1226514 NEW

**JIC Female 37° Seat with double Hexagon
DKJ and solid nut**

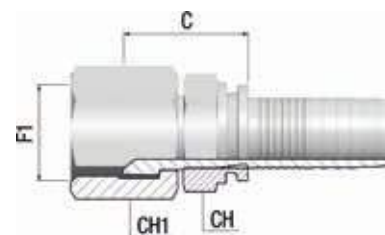

Item Code	Product Code	Nut Type	ID (Dash)	ID (mm)	ID (in)	F1 Dash	F1	C (mm)	CH (mm)	CH1 (mm)
1244537	H1226514-040400	Slip on nut	4	6,0	1/4"	4	7/16-20	19,0	14,0	14,0
1245538	H1226514-040500	Slip on nut	4	6,0	1/4"	5	1/2-20	18,9	14,0	17,0
1248014	H122651K-040600	Slip on nut	4	6,0	1/4"	6	9/16-18	22,0	14,0	19,0
1235613	H1226514-050500	Slip on nut	5	8,0	5/16"	5	1/2-20	20,6	14,0	17,0
1245542	H1226514-050600	Slip on nut	5	8,0	5/16"	6	9/16-18	22,1	14,0	19,0
1235614	H1226514-060600	Slip on nut	6	10,0	3/8"	6	9/16-18	22,1	17,0	19,0
1248122	H122651K-060800	Slip on nut	6	10,0	3/8"	8	3/4-16	24,0	17,0	22,0
1238237	H1226514-080800	Slip on nut	8	13,0	1/2"	8	3/4-16	25,7	19,0	22,0
1248016	H122651K-081000	Slip on nut	8	13,0	1/2"	10	7/8-14	29,0	19,0	27,0
1235615	H1226514-101000	Slip on nut	10	16,0	5/8"	10	7/8-14	29,2	24,0	27,0
1248017	H122651K-101200	Slip on nut	10	16,0	5/8"	12	1 1/16-12	28,6	24,0	32,0
1235616	H1226514-121200	Slip on nut	12	19,0	3/4"	12	1 1/16-12	29,7	27,0	32,0
1248018	H122651K-121600	Slip on nut	12	19,0	3/4"	16	1 5/16-12	36,1	32,0	41,0
1235617	H1226514-161600	Slip on nut	16	25,0	1"	16	1 5/16-12	33,9	32,0	41,0

Product Codes roots ending with K: insert with double hexagon knurled (ex. H122651K).

// H1222541-M

**45° JIC Female 37° Seat
Medium Drop
DKJ 45M
Solid one piece**

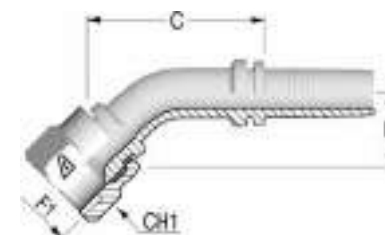

Item Code	Product Code	Nut Type	ID (Dash)	ID (mm)	ID (in)	F1 Dash	F1	C (mm)	D Drop (mm)	CH1 (mm)
1202821	H1222541-03040M	Crimped	3	5,0	3/16"	4	7/16-20	37,1	10,0	16,0
1202822	H1222541-04040M	Crimped	4	6,0	1/4"	4	7/16-20	36,6	10,0	16,0
1202823	H1222541-04050M	Crimped	4	6,0	1/4"	5	1/2-20	37,2	12,0	17,0
1202824	H1222541-04060M	Crimped	4	6,0	1/4"	6	9/16-18	39,4	11,0	19,0
1202825	H1222541-05050M	Crimped	5	8,0	5/16"	5	1/2-20	39,8	12,0	17,0
1202826	H1222541-05060M	Crimped	5	8,0	5/16"	6	9/16-18	42,8	12,0	19,0
1202827	H1222541-06060M	Crimped	6	10,0	3/8"	6	9/16-18	46,3	11,0	19,0
1202791	H1222541-06080M	Crimped	6	10,0	3/8"	8	3/4-16	47,2	15,0	25,0
1202828	H1222541-08080M	Crimped	8	13,0	1/2"	8	3/4-16	51,6	15,0	25,0
1202829	H1222541-08100M	Crimped	8	13,0	1/2"	10	7/8-14	50,7	16,0	27,0
1202830	H1222541-08120M	Crimped	8	13,0	1/2"	12	1 1/16-12	57,0	21,0	32,0
1202832	H1222541-10100M	Crimped	10	16,0	5/8"	10	7/8-14	62,2	19,0	27,0
1202831	H1222541-10120M	Crimped	10	16,0	5/8"	12	1 1/16-12	68,6	21,0	32,0
1202833	H1222541-12120M	Crimped	12	19,0	3/4"	12	1 1/16-12	67,5	21,0	32,0
1200778	H1222541-121400	Crimped	12	19,0	3/4"	14	1 3/16-12	67,6	23,0	36,0
1202834	H1222541-12160M	Crimped	12	19,0	3/4"	16	1 5/16-12	71,4	26,0	38,0
1202835	H1222541-16160M	Crimped	16	25,0	1"	16	1 5/16-12	79,4	24,0	38,0
1202836	H1222542-16200M	Thrust wire nut	16	25,0	1"	20	1 5/8-12	83,8	37,0	50,0
1202837	H1222542-20200M	Thrust wire nut	20	32,0	1 1/4"	20	1 5/8-12	97,1	37,0	50,0
1202839	H1222542-24240M	Thrust wire nut	24	38,0	1 1/2"	24	1 7/8-12	112,7	43,0	55,0
1202840	H1222542-32320M	Thrust wire nut	32	51,0	2"	32	2 1/2-12	159,9	67,0	70,0

Image: insert with Crimped Nut.

REV.2.1

// H1226544-M **NEW**

45° JIC Female 37° Seat

Medium Drop

DKJ 45M

Solid nut and double Hexagon crimped

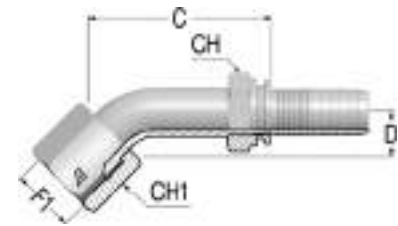

Item Code	Product Code	Nut Type	ID (Dash)	ID (mm)	ID (in)	F1 Dash	F1	C (mm)	D Drop (mm)	CH (mm)	CH1 (mm)
1241580	H1226544-04040M	Slip on nut	4	6,0	1/4"	4	7/16-20	37,0	10,0	14,0	14,0
1243629	H1226544-04060M	Slip on nut	4	6,0	1/4"	6	9/16-18	39,4	11,0	14,0	19,0
1241581	H1226544-05050M	Slip on nut	5	8,0	5/16"	5	1/2-20	40,0	11,0	14,0	17,0
1241582	H1226544-06060M	Slip on nut	6	10,0	3/8"	6	9/16-18	46,0	11,0	17,0	19,0
1244831	H1226544-06080M	Slip on nut	6	10,0	3/8"	8	3/4-16	47,0	22,0	17,0	22,0
1241583	H1226544-08080M	Slip on nut	8	13,0	1/2"	8	3/4-16	52,0	15,0	19,0	22,0
1245511	H1226544-08100M	Slip on nut	8	13,0	1/2"	10	7/8-14	51,0	16,0	19,0	27,0
1241585	H1226544-10100M	Slip on nut	10	16,0	5/8"	10	7/8-14	63,4	16,0	24,0	27,0
1244829	H1226544-10120M	Slip on nut	10	16,0	5/8"	12	1 1/16-12	69,0	21,0	24,0	32,0
1241586	H1226544-12120M	Slip on nut	12	19,0	3/4"	12	1 1/16-12	67,0	21,0	27,0	32,0
1246147	H1226544-12160M	Slip on nut	12	19,0	3/4"	16	1 5/16-12	71,0	24,0	27,0	41,0
1241587	H1226544-16160M	Slip on nut	16	25,0	1"	16	1 5/16-12	80,0	24,0	32,0	41,0

// H1222591-S

90° JIC Female 37° Seat

Short Drop

DKJ 90S

Solid one piece

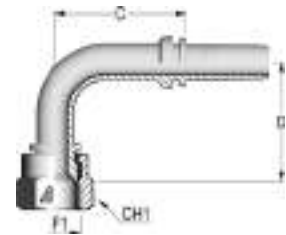

Item Code	Product Code	Nut Type	ID (Dash)	ID (mm)	ID (in)	F1 Dash	F1	C (mm)	D Drop (mm)	CH1 (mm)
1202841	H1222591-03040S	Crimped	3	5,0	3/16"	4	7/16-20	26,7	21,0	16,0
1202772	H1222591-04040S	Crimped	4	6,0	1/4"	4	7/16-20	27,0	21,0	16,0
1203118	H1222591-04050S	Crimped	4	6,0	1/4"	5	1/2-20	26,5	23,5	17,0
1202788	H1222591-04060S	Crimped	4	6,0	1/4"	6	9/16-18	31,0	23,0	19,0
1203116	H1222591-05060S	Crimped	5	8,0	5/16"	6	9/16-18	42,7	23,0	19,0
1216771	H1222591-06050S	Crimped	6	10,0	3/8"	5	1/2-20	33,3	25,0	17,0
1203032	H1222591-06060S	Crimped	6	10,0	3/8"	6	9/16-18	42,3	25,0	19,0
1203033	H1222591-06080S	Crimped	6	10,0	3/8"	8	3/4-16	48,8	29,0	25,0
1203034	H1222591-08080S	Crimped	8	13,0	1/2"	8	3/4-16	46,4	29,0	25,0
1202815	H1222591-08100S	Crimped	8	13,0	1/2"	10	7/8-14	45,8	32,0	27,0
1202744	H1222591-08120S	Crimped	8	13,0	1/2"	12	1 1/16-12	37,3	46,0	32,0
1203035	H1222591-1010BS	Crimped	10	16,0	5/8"	10	7/8-14	36,5	32,0	27,0
1202745	H1222591-10120S	Crimped	10	16,0	5/8"	12	1 1/16-12	47,9	48,0	32,0
1202845	H1222591-12120S	Crimped	12	19,0	3/4"	12	1 1/16-12	58,2	46,0	32,0
1200780	H1222591-12140S	Crimped	12	19,0	3/4"	14	1 3/16-12	49,6	52,5	36,0
1202846	H1222591-12160S	Crimped	12	19,0	3/4"	16	1 5/16-12	53,6	53,0	38,0
1203036	H1222591-16160S	Crimped	16	25,0	1"	16	1 5/16-12	74,0	56,0	38,0

// H1226594-S NEW

90° JIC Female 37° Seat

Short Drop

Solid Nut and double Hexagon crimped

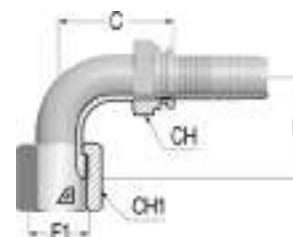

Item Code	Product Code	Nut Type	ID (Dash)	ID (mm)	ID (in)	F1 Dash	F1	C (mm)	D Drop (mm)	CH (mm)	CH1 (mm)
1243637	H1226594-04040S	Slip on nut	4	6,0	1/4"	4	7/16-20	27,0	21,0	14,0	14,0
1245516	H1226594-04050S	Slip on nut	4	6,0	1/4"	5	1/2-20	26,5	21,0	14,0	17,0
1243632	H1226594-04060S	Slip on nut	4	6,0	1/4"	6	9/16-18	30,7	23,0	14,0	19,0
1245523	H1226594-05060S	Slip on nut	5	8,0	5/16"	6	9/16-18	41,0	23,0	14,0	19,0
1243634	H1226594-06060S	Slip on nut	6	10,0	3/8"	6	9/16-18	40,3	24,5	17,0	19,0
1243641	H1226594-06080S	Slip on nut	6	10,0	3/8"	8	3/4-16	48,8	29,0	17,0	22,0
1243644	H1226594-08080S	Slip on nut	8	13,0	1/2"	8	3/4-16	46,0	29,0	19,0	22,0
1245562	H1226594-08100S	Slip on nut	8	13,0	1/2"	10	7/8-14	46,0	32,0	19,0	27,0
1244849	H1226594-10120S	Slip on nut	10	16,0	5/8"	12	1 1/16-12	48,0	48,0	24,0	32,0
1243635	H1226594-12120S	Slip on nut	12	19,0	3/4"	12	1 1/16-12	62,4	48,0	27,0	32,0
1246115	H1222593-12160S	Slip on nut	12	19,0	3/4"	16	1 5/16-12	53,6	53,0		41,0
1245568	H1226594-16160S	Slip on nut	16	25,0	1"	16	1 5/16-12	74,0	56,0	32,0	41,0

Product Codes roots ending with 3: insert with turned ring (ex. H1222593).

// H1222591-M

90° JIC Female 37° Seat

Medium Drop

DKJ 90M

Solid one piece

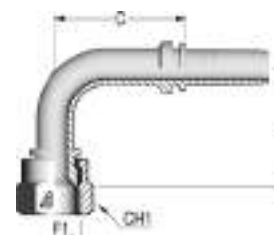

Item Code	Product Code	Nut Type	ID (Dash)	ID (mm)	ID (in)	F1 Dash	F1	C (mm)	D Drop (mm)	CH1 (mm)
1202792	H1222591-03040M	Crimped	3	5,0	3/16"	4	7/16-20	33,5	32,0	16,0
1202739	H1222591-04040M	Crimped	4	6,0	1/4"	4	7/16-20	34,2	32,0	16,0
1202740	H1222591-04050M	Crimped	4	6,0	1/4"	5	1/2-20	25,7	30,0	17,0
1202793	H1222591-04060M	Crimped	4	6,0	1/4"	6	9/16-18	28,5	38,0	19,0
1202794	H1222591-05050M	Crimped	5	8,0	5/16"	5	1/2-20	34,2	32,0	17,0
1202731	H1222591-05060M	Crimped	5	8,0	5/16"	6	9/16-18	33,2	35,0	19,0
1202742	H1222591-06060M	Crimped	6	10,0	3/8"	6	9/16-18	31,3	35,0	19,0
1202732	H1222591-06080M	Crimped	6	10,0	3/8"	8	3/4-16	39,5	41,0	25,0
1200693	H1222591-06100M	Crimped	6	10,0	3/8"	10	7/8-14	44,6	47,0	27,0
1202743	H1222591-08080M	Crimped	8	13,0	1/2"	8	3/4-16	37,2	40,0	25,0
1202741	H1222591-08100M	Crimped	8	13,0	1/2"	10	7/8-14	43,3	47,0	27,0
1202844	H1222591-10100M	Crimped	10	16,0	5/8"	10	7/8-14	49,4	48,0	27,0
1216778	H1222591-10120M	Crimped	10	16,0	5/8"	12	1 1/16-12	47,9	58,0	32,0
1202746	H1222591-12120M	Crimped	12	19,0	3/4"	12	1 1/16-12	52,4	54,0	32,0
1216780	H1222591-12160M	Crimped	12	19,0	3/4"	16	1 5/16-12	52,6	72,0	38,0
1202847	H1222591-16160M	Crimped	16	25,0	1"	16	1 5/16-12	72,6	71,5	38,0
1202848	H1222592-16200M	Thrust wire nut	16	25,0	1"	20	1 5/8-12	72,6	78,0	50,0
1202849	H1222592-20200M	Thrust wire nut	20	32,0	1 1/4"	20	1 5/8-12	82,4	78,0	50,0
1202850	H1222592-20240M	Thrust wire nut	20	32,0	1 1/4"	24	1 7/8-12	87,3	82,0	55,0
1202851	H1222592-24240M	Thrust wire nut	24	38,0	1 1/2"	24	1 7/8-12	95,3	92,0	55,0
1202852	H1222592-32320M	Thrust wire nut	32	51,0	2"	32	2 1/2-12	129,5	140,0	70,0

Image: insert with Crimped Nut.

REV.2.1

// H1226594-M **NEW**

90° JIC Female 37° Seat

Medium Drop

Solid Nut and double Hexagon crimped

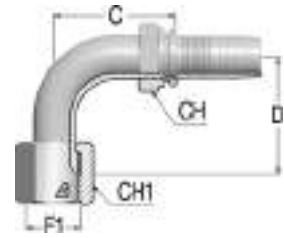

Item Code	Product Code	Nut Type	ID (Dash)	ID (mm)	ID (in)	F1 Dash	F1	C (mm)	D Drop (mm)	CH (mm)	CH1 (mm)
1241588	H1226594-04040M	Slip on nut	4	6,0	1/4"	4	7/16-20	34,0	32,0	14,0	14,0
1245515	H1226594-04050M	Slip on nut	4	6,0	1/4"	5	1/2-20	26,0	32,0	14,0	17,0
1235584	H1222593-04060M	Slip on nut	4	6,0	1/4"	6	9/16-18	31,0	38,0		19,0
1241589	H1226594-05050M	Slip on nut	5	8,0	5/16"	5	1/2-20	34,0	32,0	14,0	17,0
1245522	H1226594-05060M	Slip on nut	5	8,0	5/16"	6	9/16-18	33,0	35,0	14,0	19,0
1241590	H1226594-06060M	Slip on nut	6	10,0	3/8"	6	9/16-18	31,3	38,0	17,0	19,0
1245576	H1222593-06080M	Slip on nut	6	10,0	3/8"	8	3/4-16	41,0	39,5		22,0
1241591	H1226594-08080M	Slip on nut	8	13,0	1/2"	8	3/4-16	37,2	41,0	19,0	22,0
1245560	H1226594-08100M	Slip on nut	8	13,0	1/2"	10	7/8-14	43,3	47,0	19,0	27,0
1241592	H1226594-10100M	Slip on nut	10	16,0	5/8"	10	7/8-14	49,4	47,0	24,0	27,0
1245565	H1226594-10120M	Slip on nut	10	16,0	5/8"	12	1 1/16-12	48,0	58,0	24,0	32,0
1241593	H1226594-12120M	Slip on nut	12	19,0	3/4"	12	1 1/16-12	52,0	58,0	27,0	32,0
1246116	H1222593-12160M	Slip on nut	12	19,0	3/4"	16	1 5/16-12	52,6	71,0		41,0
1241594	H1226594-16160M	Slip on nut	16	25,0	1"	16	1 5/16-12	73,0	71,0	32,0	41,0

Product Codes roots ending with 3: insert with turned ring (ex. H1222593).

// H1222591-L

90° JIC Female 37° Seat

Long Drop

DKJ 90L

Solid one piece

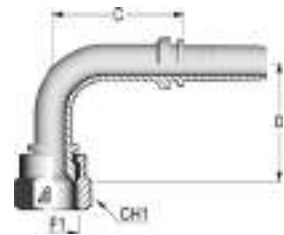

Item Code	Product Code	Nut Type	ID (Dash)	ID (mm)	ID (in)	F1 Dash	F1	C (mm)	D Drop (mm)	CH1 (mm)
1203131	H1222591-04040L	Crimped	4	6,0	1/4"	4	7/16-20	30,8	46,0	16,0
1214215	H1222591-04050L	Crimped	4	6,0	1/4"	5	1/2-20	31,3	45,0	17,0
1203115	H1222591-06060L	Crimped	6	10,0	3/8"	6	9/16-18	43,3	54,0	19,0
1202842	H1222591-06080L	Crimped	6	10,0	3/8"	8	3/4-16	46,8	64,0	25,0
1214216	H1222591-08080L	Crimped	8	13,0	1/2"	8	3/4-16	49,9	64,0	25,0
1202843	H1222591-08100L	Crimped	8	13,0	1/2"	10	7/8-14	37,3	65,0	27,0
1203114	H1222591-10100L	Crimped	10	16,0	5/8"	10	7/8-14	49,9	65,0	27,0
1203112	H1222591-12120L	Crimped	12	19,0	3/4"	12	1 1/16-12	54,1	95,0	32,0
1203111	H1222591-16160L	Crimped	16	25,0	1"	16	1 5/16-12	78,6	114,0	38,0

// H1226594-L NEW

90° JIC Female 37° Seat

Long Drop

Solid Nut and double Hexagon crimped

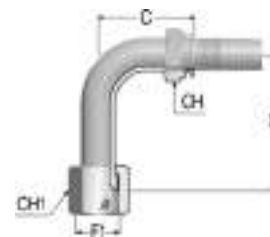

Item Code	Product Code	Nut Type	ID (Dash)	ID (mm)	ID (in)	F1 Dash	F1	C (mm)	D Drop (mm)	CH (mm)	CH1 (mm)
1244851	H1226594-04040L	Slip on nut	4	6,0	1/4"	4	7/16-20	31,0	46,0	14,0	14,0
1245514	H1226594-04050L	Slip on nut	4	6,0	1/4"	5	1/2-20	31,0	46,0	14,0	17,0
1244845	H1226594-06060L	Slip on nut	6	10,0	3/8"	6	9/16-18	43,3	54,0	17,0	17,0
1245766	H1222593-06080L	Slip on nut	6	10,0	3/8"	8	3/4-16	47,0	64,0		22,0
1245557	H1226594-08080L	Slip on nut	8	13,0	1/2"	8	3/4-16	49,9	64,0	19,0	22,0
1244846	H1226594-08100L	Slip on nut	8	13,0	1/2"	10	7/8-14	37,2	65,0	19,0	27,0
1244847	H1226594-10100L	Slip on nut	10	16,0	5/8"	10	7/8-14	50,0	70,0	24,0	27,0
1244850	H1226594-12120L	Slip on nut	12	19,0	3/4"	12	1 1/16-12	54,0	96,0	27,0	32,0
1245567	H1226594-16160L	Slip on nut	16	25,0	1"	16	1 5/16-12	79,0	114,0	32,0	41,0

Product Codes roots ending with 3: insert with turned ring (ex. H1222593).

// NPTF INSERTS

// H1212810

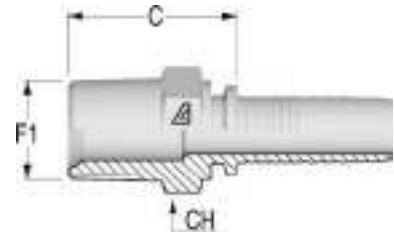
NPTF Male 60° Seat
AGN

Item Code	Product Code	ID (Dash)	ID (mm)	ID (in)	F1 Dash	F1	C (mm)	CH (mm)
1200448	H1212810-030200	3	5,0	3/16"	2	1/8-27	20,8	12,0
1200466	H1212810-040200	4	6,0	1/4"	2	1/8-27	21,3	14,0
1228235	H121281P-040400	4	6,0	1/4"	4	1/4-18	26,8	14,3
1200467	H1212810-040600	4	6,0	1/4"	6	3/8-18	27,8	19,0
1203150	H1212810-040800	4	6,0	1/4"	8	1/2-14	31,3	22,0
1200511	H1212810-050400	5	8,0	5/16"	4	1/4-18	26,8	17,0
1200512	H1212810-050600	5	8,0	5/16"	6	3/8-18	27,8	19,0
1200307	H1212810-060400	6	10,0	3/8"	4	1/4-18	26,8	17,0
1200308	H1212810-060600	6	10,0	3/8"	6	3/8-18	27,8	19,0
1200306	H1212810-060800	6	10,0	3/8"	8	1/2-14	31,3	22,0
1200345	H1212810-080600	8	13,0	1/2"	6	3/8-18	28,6	19,0
1200343	H1212810-080800	8	13,0	1/2"	8	1/2-14	32,1	22,0
1200344	H1212810-081200	8	13,0	1/2"	12	3/4-14	34,1	27,0
1200387	H1212810-100800	10	16,0	5/8"	8	1/2-14	33,1	24,0
1200388	H1212810-101200	10	16,0	5/8"	12	3/4-14	34,1	27,0
1203149	H1212810-120800	12	19,0	3/4"	8	1/2-14	33,6	27,0
1200421	H1212810-121200	12	19,0	3/4"	12	3/4-14	34,6	27,0
1200420	H1212810-121600	12	19,0	3/4"	16	1-11 1/2	43,6	36,0
1216610	H1212810-141600	14	22,0	7/8"	16	1-11 1/2	43,6	36,0
1202282	H1212810-161200	16	25,0	1"	12	3/4-14	39,4	36,0
1201366	H1212810-161600	16	25,0	1"	16	1-11 1/2	44,4	36,0
1201367	H1212810-162000	16	25,0	1"	20	1 1/4-11 1/2	47,4	46,0
1201368	H1212810-202000	20	32,0	1 1/4"	20	1 1/4-11 1/2	49,0	46,0
1201369	H1212810-242400	24	38,0	1 1/2"	24	1 1/2-11 1/2	50,5	50,0
1216613	H1212810-293200	29	46,0	1 13/16"	32	2-11 1/2	54,2	65,0
1201370	H1212810-323200	32	51,0	2"	32	2-11 1/2	54,2	65,0

// H1222810

NPTF Female Solid

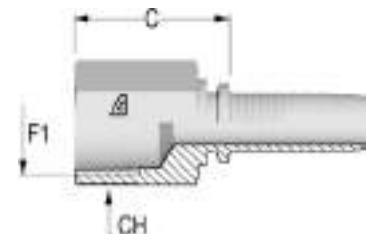

Item Code	Product Code	ID (Dash)	ID (mm)	ID (in)	F1 Dash	F1	C (mm)	CH (mm)
1216794	H1222810-040200	4	6,0	1/4"	2	1/8-27	22,3	14,0
1200464	H1222810-040400	4	6,0	1/4"	4	1/4-18	27,8	19,0
1219145	H1222810-060600	6	10,0	3/8"	6	3/8-18	28,8	22,0
1216795	H1222810-080800	8	13,0	1/2"	8	1/2-14	35,6	25,0
1216796	H1222810-121200	12	19,0	3/4"	12	3/4-14	38,1	32,0
1216797	H1222810-161600	16	25,0	1"	16	1-11 1/2	44,9	38,0

// H1212811
NPTF Male Swivel 60° Seat

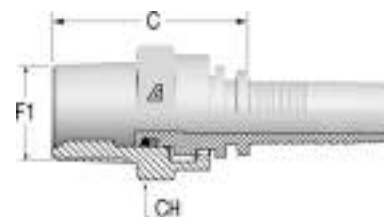

Item Code	Product Code	Nut Type	ID (Dash)	ID (mm)	ID (in)	F1 Dash	F1	C (mm)	CH (mm)
1216614	H1212811-040400	Crimped	4	6,0	1/4"	4	1/4-18	37,6	17,0
1216615	H1212811-040600	Crimped	4	6,0	1/4"	6	3/8-18	39,5	22,0
1216616	H1212811-060400	Crimped	6	10,0	3/8"	4	1/4-18	39,6	17,0
1214186	H1212811-060600	Crimped	6	10,0	3/8"	6	3/8-18	37,5	22,0
1216617	H1212811-060800	Crimped	6	10,0	3/8"	8	1/2-14	43,5	25,0
1216619	H1212811-080600	Crimped	8	13,0	1/2"	6	3/8-18	38,3	22,0
1214187	H1212811-080800	Crimped	8	13,0	1/2"	8	1/2-14	42,3	25,0
1216620	H1212811-121200	Crimped	12	19,0	3/4"	12	3/4-14	50,1	32,0
1216621	H1212811-161600	Crimped	16	25,0	1"	16	1-11 1/2	57,9	41,0

// H1212881
90° Compact NPTF Male Swivel 60° Seat

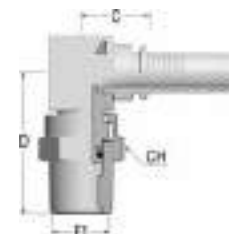

Item Code	Product Code	Nut Type	ID (Dash)	ID (mm)	ID (in)	F1 Dash	F1	C (mm)	D Drop (mm)	CH (mm)
1225918	H1212881-040400	Crimped	4	6,0	1/4"	4	1/4-18	17,0	39,0	17,0
1225920	H1212881-060600	Crimped	6	10,0	3/8"	6	3/8-18	20,0	41,0	22,0
1225921	H1212881-080800	Crimped	8	13,0	1/2"	8	1/2-14	21,6	49,7	19,0
1225922	H1212881-121200	Crimped	12	19,0	3/4"	12	3/4-14	27,0	61,0	32,0

REV.2.1

// NPSM INSERTS

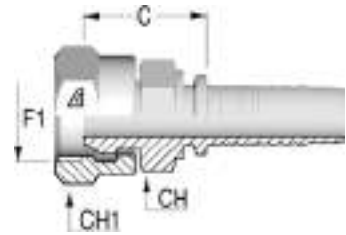
// H1227311
NPSM Female

Item Code	Product Code	Nut Type	ID (Dash)	ID (mm)	ID (in)	F1 Dash	F1	C (mm)	CH (mm)	CH1 (mm)
1203280	H1227311-040400	Crimped	4	6,0	1/4"	4	1/4-18	24,3	17,0	19,0
1216834	H1227311-060600	Crimped	6	10,0	3/8"	6	3/8-18	24,8	19,0	22,0
1202084	H1227311-080800	Crimped	8	13,0	1/2"	8	1/2-14	26,6	22,0	27,0
1216835	H1227311-121200	Crimped	12	19,0	3/4"	12	3/4-14	20,6		32,0
1216836	H1227311-161600	Crimped	16	25,0	1"	16	1-11 1/2	35,4	36,0	38,0

1216835: without Stem Hexagon, with O-Ring

// ORFS INSERTS

// H1212410 ORFS Male

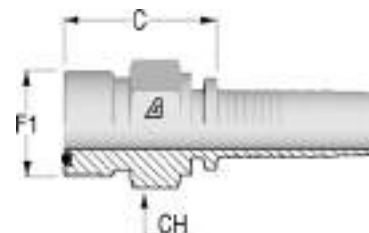

Item Code	Product Code	ID (Dash)	ID (mm)	ID (in)	F1 Dash	F1	C (mm)	CH (mm)
1202488	H1212410-040400	4	6,0	1/4"	4	9/16-18	22,3	17,0
1202489	H1212410-040600	4	6,0	1/4"	6	11/16-16	24,3	19,0
1214185	H1212410-050600	5	8,0	5/16"	6	11/16-16	24,3	19,0
1202490	H1212410-060600	6	10,0	3/8"	6	11/16-16	24,3	19,0
1202491	H1212410-060800	6	10,0	3/8"	8	13/16-16	26,3	22,0
1202055	H1212410-061000	6	10,0	3/8"	10	1-14	29,8	27,0
1202492	H1212410-080800	8	13,0	1/2"	8	13/16-16	27,1	22,0
1202054	H1212410-081000	8	13,0	1/2"	10	1-14	30,6	27,0
1202493	H1212410-081200	8	13,0	1/2"	12	1 3/16-12	34,1	32,0
1202892	H1212410-101000	10	16,0	5/8"	10	1-14	30,6	27,0
1202494	H1212410-101200	10	16,0	5/8"	12	1 3/16-12	34,1	32,0
1202495	H1212410-121000	12	19,0	3/4"	10	1-14	31,1	27,0
1202496	H1212410-121200	12	19,0	3/4"	12	1 3/16-12	34,6	32,0
1202497	H1212410-121600	12	19,0	3/4"	16	1 7/16-12	38,1	41,0
1202498	H1212410-161600	16	25,0	1"	16	1 7/16-12	37,9	38,0
1202499	H1212410-162000	16	25,0	1"	20	1 11/16-12	39,9	46,0
1202500	H1212410-202000	20	32,0	1 1/4"	20	1 11/16-12	41,5	46,0

// H1222414 **NEW** ORFS Female with support Hexagon knurled

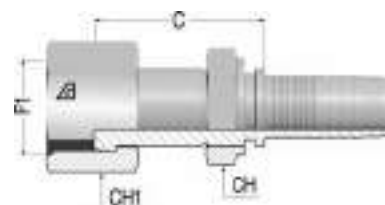

Item Code	Product Code	Nut Type	ID (Dash)	ID (mm)	ID (in)	F1 Dash	F1	C (mm)	CH (mm)	CH1 (mm)
1240013	H1222414-040400	Slip on nut	4	6,0	1/4"	4	9/16-18	29,5	14,0	17,0
1245728	H1222414-040600	Slip on nut	4	6,0	1/4"	6	11/16-16	31,8	17,0	22,0
1245899	H1222414-040800	Slip on nut	4	6,0	1/4"	8	13/16-16	35,8	22,0	24,0
1245428	H1222414-050600	Slip on nut	5	8,0	5/16"	6	11/16-16	38,0	17,0	22,0
1240034	H1222414-060600	Slip on nut	6	10,0	3/8"	6	11/16-16	32,3	17,0	22,0
1245892	H1222414-060800	Slip on nut	6	10,0	3/8"	8	13/16-16	39,3	22,0	24,0
1240035	H1222414-080800	Slip on nut	8	13,0	1/2"	8	13/16-16	40,5	22,0	24,0
1245429	H1222414-081000	Slip on nut	8	13,0	1/2"	10	1-14	43,0	24,0	30,0
1245904	H1222414-081200	Slip on nut	8	13,0	1/2"	12	1 3/16-12	42,1	30,0	36,0
1240036	H1222414-101000	Slip on nut	10	16,0	5/8"	10	1-14	39,6	27,0	30,0
1245905	H1222414-101200	Slip on nut	10	16,0	5/8"	12	1 3/16-12	42,1	30,0	36,0
1240038	H1222414-121200	Slip on nut	12	19,0	3/4"	12	1 3/16-12	42,6	30,0	36,0
1245906	H1222414-121600	Slip on nut	12	19,0	3/4"	16	1 7/16-12	50,6	36,0	41,0
1242623	H1222414-161600	Slip on nut	16	25,0	1"	16	1 7/16-12	51,4	36,0	41,0

REV.2.1

// H1222443-M

45° ORFS Female

Medium Drop

DK ORFS 45M

Solid one piece

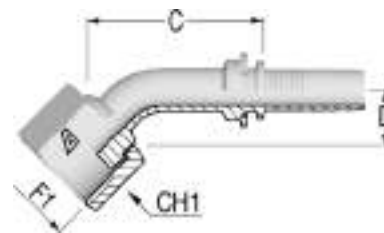

Item Code	Product Code	Nut Type	ID (Dash)	ID (mm)	ID (in)	F1 Dash	F1	C (mm)	D Drop (mm)	CH1 (mm)
1202774	H1222443-04040M	Slip on nut	4	6,0	1/4"	4	9/16-18	41,1	11,0	17,0
1202775	H1222443-04060M	Slip on nut	4	6,0	1/4"	6	11/16-16	46,1	11,0	22,0
1202871	H1222443-05060M	Slip on nut	5	8,0	5/16"	6	11/16-16	46,3	12,0	22,0
1202776	H1222443-06060M	Slip on nut	6	10,0	3/8"	6	11/16-16	47,4	12,0	22,0
1202777	H1222443-06080M	Slip on nut	6	10,0	3/8"	8	13/16-16	51,2	15,0	24,0
1202854	H1222441-08080M	Crimped	8	13,0	1/2"	8	13/16-16	47,1	16,0	24,0
1202771	H1222443-08100M	Slip on nut	8	13,0	1/2"	10	1-14	50,4	16,5	30,0
1202819	H1222443-10100M	Slip on nut	10	16,0	5/8"	10	1-14	57,7	17,0	30,0
1202853	H1222443-10120M	Slip on nut	10	16,0	5/8"	12	1 3/16-12	63,1	21,0	36,0
1203060	H1222441-12100M	Crimped	12	19,0	3/4"	10	1-14	51,4	24,0	30,0
1202872	H1222443-12120M	Slip on nut	12	19,0	3/4"	12	1 3/16-12	63,5	21,0	36,0
1202915	H1222443-12160M	Slip on nut	12	19,0	3/4"	16	1 7/16-12	70,7	24,0	41,0
1202797	H1222443-16160S	Slip on nut	16	25,0	1"	16	1 7/16-12	82,4	26,0	41,0
1203141	H1222443-16200M	Slip on nut	16	25,0	1"	20	1 11/16-12	85,4	26,0	50,0
1202873	H1222443-20200M	Slip on nut	20	32,0	1 1/4"	20	1 11/16-12	95,0	32,0	50,0
1202874	H1222443-24240M	Slip on nut	24	38,0	1 1/2"	24	2-12	104,4	28,0	60,0

Image: insert with Slip on Nut.

// H1222493-S

90° ORFS Female

Short Drop

DK ORFS 90S

Solid one piece



Item Code	Product Code	Nut Type	ID (Dash)	ID (mm)	ID (in)	F1 Dash	F1	C (mm)	D Drop (mm)	CH1 (mm)
1202778	H1222493-04040S	Slip on nut	4	6,0	1/4"	4	9/16-18	28,5	21,0	17,0
1202856	H1222493-04060S	Slip on nut	4	6,0	1/4"	6	11/16-16	32,0	23,0	22,0
1202857	H1222493-05060S	Slip on nut	5	8,0	5/16"	6	11/16-16	50,1	23,5	22,0
1202858	H1222493-06060S	Slip on nut	6	10,0	3/8"	6	11/16-16	40,0	27,0	22,0
1202859	H1222493-06080S	Slip on nut	6	10,0	3/8"	8	13/16-16	41,8	29,0	24,0
1203392	H1222491-08060S	Crimped	8	13,0	1/2"	6	11/16-16	44,1	25,0	22,0
1202855	H1222491-08080S	Crimped	8	13,0	1/2"	8	13/16-16	39,8	29,0	24,0
1203054	H1222493-08100S	Slip on nut	8	13,0	1/2"	10	1-14	46,3	32,5	30,0
1203334	H1222493-08120S	Slip on nut	8	13,0	1/2"	12	1 3/16-12	56,3	51,0	36,0
1202860	H1222493-10100S	Slip on nut	10	16,0	5/8"	10	1-14	52,3	32,5	30,0
1202861	H1222493-10120S	Slip on nut	10	16,0	5/8"	12	1 3/16-12	55,4	49,0	36,0
1202862	H1222493-12120S	Slip on nut	12	19,0	3/4"	12	1 3/16-12	60,6	51,0	36,0
1203055	H1222493-12160S	Slip on nut	12	19,0	3/4"	16	1 7/16-12	61,6	56,0	41,0
1203209	H1222491-16120S	Crimped	16	25,0	1"	12	1 3/16-12	54,6	51,0	36,0
1202863	H1222493-16160S	Slip on nut	16	25,0	1"	16	1 7/16-12	80,0	58,0	41,0
1203135	H1222493-16200S	Slip on nut	16	25,0	1"	20	1 11/16-12	82,6	64,0	50,0
1203133	H1222493-20200S	Slip on nut	20	32,0	1 1/4"	20	1 11/16-12	95,0	68,0	50,0
1214213	H1222493-24240S	Slip on nut	24	38,0	1 1/2"	24	2-12	103,7	78,0	60,0

Image: insert with Slip on Nut.

// H1222493-M
90° ORFS Female
Medium Drop
DK ORFS 90M
Solid one piece



Item Code	Product Code	Nut Type	ID (Dash)	ID (mm)	ID (in)	F1 Dash	F1	C (mm)	D Drop (mm)	CH1 (mm)
1202875	H1222493-04040M	Slip on nut	4	6,0	1/4"	4	9/16-18	29,8	32,0	17,0
1202715	H1222493-04060M	Slip on nut	4	6,0	1/4"	6	11/16-16	37,3	38,0	22,0
1202779	H1222493-05060M	Slip on nut	5	8,0	5/16"	6	11/16-16	40,7	34,0	22,0
1202780	H1222493-06060M	Slip on nut	6	10,0	3/8"	6	11/16-16	41,8	38,0	22,0
1202716	H1222493-06080M	Slip on nut	6	10,0	3/8"	8	13/16-16	43,8	41,0	24,0
1202781	H1222491-08080M	Crimped	8	13,0	1/2"	8	13/16-16	34,8	42,0	24,0
1202770	H1222493-08100M	Slip on nut	8	13,0	1/2"	10	1-14	48,3	47,0	30,0
1202782	H1222493-10100M	Slip on nut	10	16,0	5/8"	10	1-14	55,4	44,0	30,0
1203137	H1222493-10120M	Slip on nut	10	16,0	5/8"	12	1 3/16-12	55,4	58,0	36,0
1202783	H1222493-12120M	Slip on nut	12	19,0	3/4"	12	1 3/16-12	61,6	58,0	36,0
1202916	H1222493-12160M	Slip on nut	12	19,0	3/4"	16	1 7/16-12	65,6	71,0	41,0
1216748	H1222491-16120M	Crimped	16	25,0	1"	12	1 3/16-12	62,6	58,0	36,0
1202717	H1222493-16160M	Slip on nut	16	25,0	1"	16	1 7/16-12	82,6	66,0	41,0
1203069	H1222493-16200M	Slip on nut	16	25,0	1"	20	1 11/16-12	82,6	78,0	50,0
1202876	H1222493-20200M	Slip on nut	20	32,0	1 1/4"	20	1 11/16-12	97,0	78,0	50,0
1202877	H1222493-24240M	Slip on nut	24	38,0	1 1/2"	24	2-12	107,8	87,0	60,0

Image: insert with Slip on Nut.

// H1222493-L
90° ORFS Female
Long Drop
DK ORFS 90L
Solid one piece



Item Code	Product Code	Nut Type	ID (Dash)	ID (mm)	ID (in)	F1 Dash	F1	C (mm)	D Drop (mm)	CH1 (mm)
1210841	H1222493-04040L	Slip on nut	4	6,0	1/4"	4	9/16-18	32,8	46,0	17,0
1203139	H1222493-04060L	Slip on nut	4	6,0	1/4"	6	11/16-16	34,8	54,0	22,0
1203138	H1222493-06060L	Slip on nut	6	10,0	3/8"	6	11/16-16	41,8	54,0	22,0
1203057	H1222493-06080L	Slip on nut	6	10,0	3/8"	8	13/16-16	46,8	64,0	24,0
1202922	H1222491-08080L	Crimped	8	13,0	1/2"	8	13/16-16	38,3	64,0	24,0
1214208	H1222493-08100L	Slip on nut	8	13,0	1/2"	10	1-14	46,3	70,0	30,0
1202918	H1222493-10100L	Slip on nut	10	16,0	5/8"	10	1-14	55,4	70,0	30,0
1202919	H1222493-10120L	Slip on nut	10	16,0	5/8"	12	1 3/16-12	55,4	96,0	36,0
1202920	H1222493-12120L	Slip on nut	12	19,0	3/4"	12	1 3/16-12	61,6	96,0	36,0
1202921	H1222493-12160L	Slip on nut	12	19,0	3/4"	16	1 7/16-12	61,6	118,0	41,0
1203136	H1222493-16160L	Slip on nut	16	25,0	1"	16	1 7/16-12	82,6	114,0	41,0
1203134	H1222493-20200L	Slip on nut	20	32,0	1 1/4"	20	1 11/16-12	97,0	129,0	50,0
1214212	H1222493-24240L	Slip on nut	24	38,0	1 1/2"	24	2-12	110,8	141,0	60,0

Image: insert with Slip on Nut.

REV.2.1

// FRENCH INSERTS

// H1211810

Metric Male - French Type

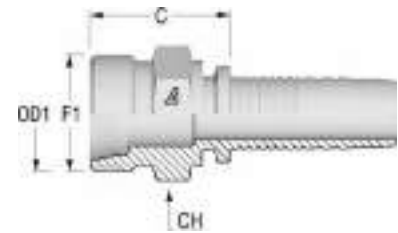

Item Code	Product Code	ID (Dash)	ID (mm)	ID (in)	F1	OD1	C (mm)	CH (mm)
1200317	H1211810-062000	6	10,0	3/8"	M20X1.5	13,25	25,3	22,0
1200361	H1211810-082400	8	13,0	1/2"	M24X1.5	16,75	27,1	24,0
1200404	H1211810-103000	10	16,0	5/8"	M30X1.5	21,25	31,1	30,0
1200435	H1211810-123600	12	19,0	3/4"	M36X1.5	26,75	33,6	36,0

// H1221813

Metric Female - French Type

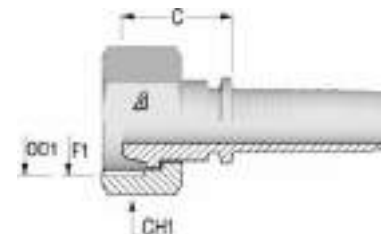

Item Code	Product Code	Nut Type	ID (Dash)	ID (mm)	ID (in)	F1	OD1	C (mm)	CH1 (mm)
1200744	H1221813-103000	Slip on nut	10	16,0	5/8"	M30X1.5	22	26,6	36,0
1200770	H1221813-123600	Slip on nut	12	19,0	3/4"	M36X1.5	28	27,0	42,0

// H1221893

90° Metric Female - French Type

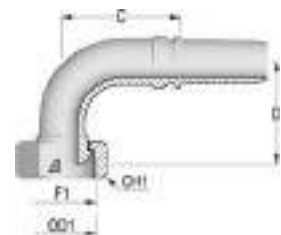

Item Code	Product Code	Nut Type	ID (Dash)	ID (mm)	ID (in)	F1	OD1	C (mm)	D Drop (mm)	CH1 (mm)
1200654	H1221893-052000	Slip on nut	5	8,0	5/16"	M20X1.5	14	32,5	36,5	24,0
1200719	H1221893-082400	Slip on nut	8	13,0	1/2"	M24X1.5	16	39,5	46,0	30,0
1203156	H1221893-103000	Slip on nut	10	16,0	5/8"	M30X1.5	22	43,0	49,0	36,0
1200773	H1221893-123600	Slip on nut	12	19,0	3/4"	M36X1.5	28	46,6	48,5	42,0

// JIS INSERTS

// H1223711

JIS Female 60° Cone - B 8363 (Type C)

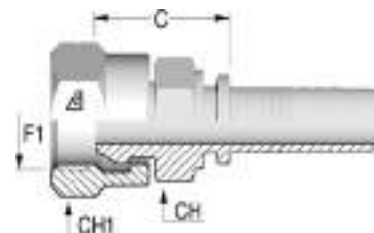

Item Code	Product Code	Nut Type	ID (Dash)	ID (mm)	ID (in)	F1 Dash	F1	C (mm)	CH (mm)	CH1 (mm)
1203110	H1223711-040400	Crimped	4	6,0	1/4"	4	1/4-19	24,3	17,0	19,0
1203109	H1223711-060600	Crimped	6	10,0	3/8"	6	3/8-19	25,5	19,0	22,0
1203108	H1223711-080800	Crimped	8	13,0	1/2"	8	1/2-14	26,1	22,0	27,0
1226069	H1223711-100800	Crimped	10	16,0	5/8"	8	1/2-14	27,1	24,0	27,0
1226549	H1223711-101200	Crimped	10	16,0	5/8"	12	3/4-14	29,6	30,0	36,0
1203107	H1223711-121200	Crimped	12	19,0	3/4"	12	3/4-14	30,1	30,0	36,0
1214218	H1223711-161600	Crimped	16	25,0	1"	16	1-11	34,9	36,0	41,0

// H1223741

45° JIS Female 60° Cone - B 8363 (Type C)

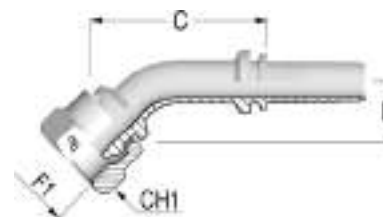

Item Code	Product Code	Nut Type	ID (Dash)	ID (mm)	ID (in)	F1 Dash	F1	C (mm)	D Drop (mm)	CH1 (mm)
1216798	H1223741-040400	Crimped	4	6,0	1/4"	4	1/4-19	24,3	19,0	19,0
1216799	H1223741-060600	Crimped	6	10,0	3/8"	6	3/8-19	26,5	21,0	22,0
1216800	H1223741-080800	Crimped	8	13,0	1/2"	8	1/2-14	27,0	22,0	27,0
1216801	H1223741-121200	Crimped	12	19,0	3/4"	12	3/4-14	19,9	25,0	36,0

// H1223791

90° JIS Female 60° Cone - B 8363 (Type C)

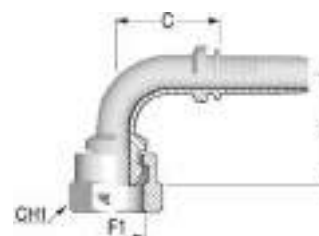

Item Code	Product Code	Nut Type	ID (Dash)	ID (mm)	ID (in)	F1 Dash	F1	C (mm)	D Drop (mm)	CH1 (mm)
1216803	H1223791-040400	Crimped	4	6,0	1/4"	4	1/4-19	25,3	33,0	19,0
1216805	H1223791-060600	Crimped	6	10,0	3/8"	6	3/8-19	32,3	36,5	22,0
1216806	H1223791-080800	Crimped	8	13,0	1/2"	8	1/2-14	37,3	38,5	27,0

REV.2.1

// H122381Z

JIS Female 60° Seat Flare - B 8363 (Type F)

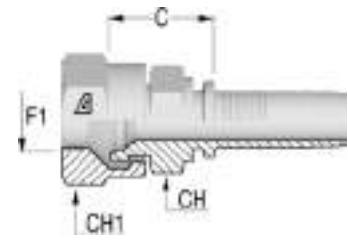

Item Code	Product Code	Nut Type	ID (Dash)	ID (mm)	ID (in)	F1 Dash	F1	C (mm)	CH (mm)	CH1 (mm)
1202947	H122381Z-040400	Crimped	4	6,0	1/4"	4	1/4-19	20,8	17,0	19,0
1202879	H122381Z-060600	Crimped	6	10,0	3/8"	6	3/8-19	21,8	19,0	22,0
1202878	H122381Z-080800	Crimped	8	13,0	1/2"	8	1/2-14	23,6	22,0	27,0
1203106	H122381Z-121200	Crimped	12	19,0	3/4"	12	3/4-14	27,1	30,0	36,0
1203105	H122381Z-161600	Crimped	16	25,0	1"	16	1-11	32,9	36,0	41,0
1201585	H122381Z-202000	Thrust wire nut	20	32,0	1 1/4"	20	1 1/4-11	39,5	46,0	50,0
1201677	H122381Z-242400	Thrust wire nut	24	38,0	1 1/2"	24	1 1/2-11	41,5	50,0	55,0

Image: insert with Crimped Nut.

// H122384Z

45° JIS Female 60° Seat Flare - B 8363 (Type F)

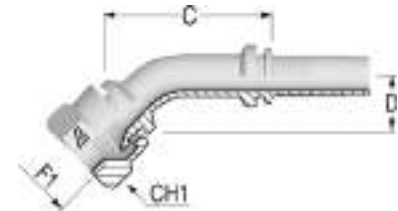

Item Code	Product Code	Nut Type	ID (Dash)	ID (mm)	ID (in)	F1 Dash	F1	C (mm)	D Drop (mm)	CH1 (mm)
1203104	H122384Z-040400	Crimped	4	6,0	1/4"	4	1/4-19	42,5	15,0	19,0

// H122389Z

90° JIS Female 60° Seat Flare - B 8363 (Type F)



Item Code	Product Code	Nut Type	ID (Dash)	ID (mm)	ID (in)	F1 Dash	F1	C (mm)	D Drop (mm)	CH1 (mm)
1203095	H122389Z-040400	Crimped	4	6,0	1/4"	4	1/4-19	27,3	29,5	19,0
1203094	H122389Z-060600	Crimped	6	10,0	3/8"	6	3/8-19	31,3	33,0	22,0
1203093	H122389Z-080800	Crimped	8	13,0	1/2"	8	1/2-14	37,3	36,5	27,0
1203092	H122389Z-121200	Crimped	12	19,0	3/4"	12	3/4-14	46,1	52,0	36,0
1203091	H122389Z-161600	Crimped	16	25,0	1"	16	1-11	77,1	64,5	41,0

// KOMATSU INSERTS

// H1224011

Komatsu Female

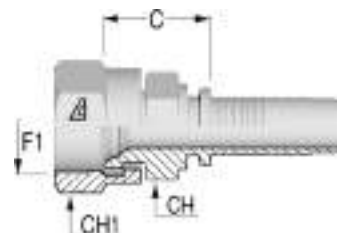

Item Code	Product Code	Nut Type	ID (Dash)	ID (mm)	ID (in)	F1 Dash	F1	C (mm)	CH (mm)	CH1 (mm)
1200502	H1224011-041400	Crimped	4	6,0	1/4"	14	M14X1.5	20,8	17,0	19,0
1216808	H1224011-061400	Crimped	6	10,0	3/8"	14	M14X1.5	20,8	17,0	19,0
1200334	H1224011-061800	Crimped	6	10,0	3/8"	18	M18X1.5	21,8	19,0	22,0
1202688	H1224011-082200	Crimped	8	13,0	1/2"	22	M22X1.5	23,6	22,0	27,0
1200414	H1224011-102400	Crimped	10	16,0	5/8"	24	M24X1.5	27,1	30,0	32,0
1200444	H1224011-123000	Crimped	12	19,0	3/4"	30	M30X1.5	27,6	30,0	36,0
1201720	H1224011-163300	Crimped	16	25,0	1"	33	M33X1.5	35,7	36,0	41,0

// H1244110

Komatsu Flange

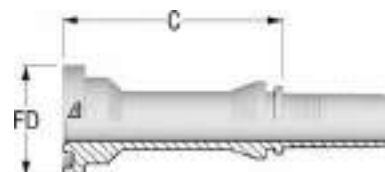

Item Code	Product Code	ID (Dash)	ID (mm)	ID (in)	F1 Dash	F1	C (mm)	FD (mm)
1201625	H1244110-101000	10	16,0	5/8"	10	5/8	46,7	34,0

// H1244140

45° Komatsu Flange

Solid one piece

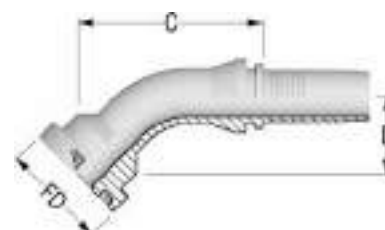

Item Code	Product Code	ID (Dash)	ID (mm)	ID (in)	F1 Dash	F1	FD (mm)	C (mm)	D Drop (mm)
1202066	H1244140-101000	10	16,0	5/8"	10	5/8	34,0	49,1	25,0

REV.2.1

// H1244190
90° Komatsu Flange
Solid one piece

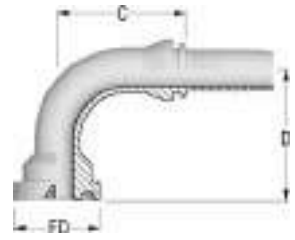

Item Code	Product Code	ID (Dash)	ID (mm)	ID (in)	F1 Dash	F1	FD (mm)	C (mm)	D Drop (mm)
1202067	H1244190-101000	10	16,0	5/8"	10	5/8	34,0	51,0	51,0

// SAE FLANGES

// H1243310

Flange SAE 3000 psi J518 Code 61
SFL

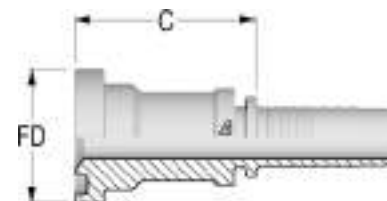

Item Code	Product Code	ID (Dash)	ID (mm)	ID (in)	F1 Dash	F1	C (mm)	FD (mm)	WP (psi)
1202747	H1243310-080800	8	13,0	1/2"	8	1/2	41,0	30,2	5000
1202763	H1243310-081200	8	13,0	1/2"	12	3/4	42,0	38,1	5000
1202801	H1243310-101200	10	16,0	5/8"	12	3/4	42,2	38,1	5000
1201734	H1243310-121200	12	19,0	3/4"	12	3/4	42,5	38,1	5000
1202750	H1243310-121600	12	19,0	3/4"	16	1	50,5	44,5	5000
1201408	H1243310-161600	16	25,0	1"	16	1	51,4	44,5	5000
1201409	H1243310-162000	16	25,0	1"	20	1 1/4	53,9	50,8	4000
1221654	H1243310-201600	20	32,0	1 1/4"	16	1	53,0	44,5	5000
1201410	H1243310-202000	20	32,0	1 1/4"	20	1 1/4	55,5	50,8	4000
1201411	H1243310-202400	20	32,0	1 1/4"	24	1 1/2	58,5	60,3	3000
1201412	H1243310-242400	24	38,0	1 1/2"	24	1 1/2	58,5	60,3	3000
1201413	H1243310-243200	24	38,0	1 1/2"	32	2	70,0	71,4	3000
1221662	H1243310-322400	32	51,0	2"	24	1 1/2	66,0	60,3	3000
1201414	H1243310-323200	32	51,0	2"	32	2	70,0	71,4	3000
1202074	H1243310-324000	32	51,0	2"	40	2 1/2	83,0	84,1	2500
1226113	H1243310-403200	40	63,0	2 1/2"	32	2	86,5	71,4	3000
1203063	H1243310-404000	40	63,0	2 1/2"	40	2 1/2	86,5	84,1	2500

// H1243320

22° Flange SAE 3000 psi J518 Code 61
SFL 22
Solid one piece

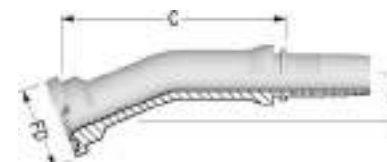

Item Code	Product Code	ID (Dash)	ID (mm)	ID (in)	F1 Dash	F1	FD (mm)	C (mm)	D Drop (mm)	WP (psi)
1216854	H1243320-161600	16	25,0	1"	16	1	44,5	92,7	12,0	5000
1216856	H1243320-202000	20	32,0	1 1/4"	20	1 1/4	50,8	113,6	16,0	4000
1216857	H1243320-202400	20	32,0	1 1/4"	24	1 1/2	60,3	114,7	20,5	3000
1216858	H1243320-242400	24	38,0	1 1/2"	24	1 1/2	60,3	131,0	22,0	3000
1216859	H1243320-323200	32	51,0	2"	32	2	71,4	153,0	22,0	3000

REV.2.1

// H1243330

30° Flange SAE 3000 psi J518 Code 61

SFL 30

Solid one piece

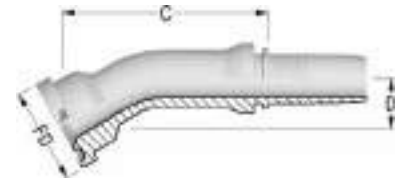

Item Code	Product Code	ID (Dash)	ID (mm)	ID (in)	F1 Dash	F1	FD (mm)	C (mm)	D Drop (mm)	WP (psi)
1216861	H1243330-121200	12	19,0	3/4"	12	3/4	38,1	80,8	12,0	5000
1216862	H1243330-121600	12	19,0	3/4"	16	1	44,5	83,8	12,0	5000
1216863	H1243330-161600	16	25,0	1"	16	1	44,5	89,8	12,0	5000
1216864	H1243330-162000	16	25,0	1"	20	1 1/4	50,8	90,0	12,0	4000
1216866	H1243330-202000	20	32,0	1 1/4"	20	1 1/4	50,8	102,4	12,0	4000
1216867	H1243330-202400	20	32,0	1 1/4"	24	1 1/2	60,3	111,9	13,0	3000
1216868	H1243330-242400	24	38,0	1 1/2"	24	1 1/2	60,3	128,6	23,0	3000
1216869	H1243330-243200	24	38,0	1 1/2"	32	2	71,4	147,0	29,5	3000

// H1243340

45° Flange SAE 3000 psi J518 Code 61

SFL 45

Solid one piece

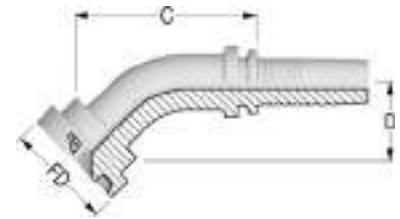

Item Code	Product Code	ID (Dash)	ID (mm)	ID (in)	F1 Dash	F1	FD (mm)	C (mm)	D Drop (mm)	WP (psi)
1202748	H1243340-080800	8	13,0	1/2"	8	1/2	30,2	69,4	22,0	5000
1202751	H1243340-081200	8	13,0	1/2"	12	3/4	38,1	60,3	26,0	5000
1202678	H1243340-121200	12	19,0	3/4"	12	3/4	38,1	73,7	32,0	5000
1202752	H1243340-121600	12	19,0	3/4"	16	1	44,5	77,9	29,0	5000
1214223	H1243340-122000	12	19,0	3/4"	20	1 1/4	50,8	81,5	30,0	5000
1202681	H1243340-161600	16	25,0	1"	16	1	44,5	82,7	33,5	5000
1201845	H1243340-162000	16	25,0	1"	20	1 1/4	50,8	82,2	36,0	4000
1216872	H1243340-201600	20	32,0	1 1/4"	16	1	44,5	114,6	35,1	5000
1201848	H1243340-202000	20	32,0	1 1/4"	20	1 1/4	50,8	95,1	37,5	4000
1202677	H1243340-202400	20	32,0	1 1/4"	24	1 1/2	60,3	104,1	40,0	3000
1216873	H1243340-242000	24	38,0	1 1/2"	20	1 1/4	50,8	144,9	49,5	4000
1202753	H1243340-242400	24	38,0	1 1/2"	24	1 1/2	60,3	116,7	48,0	3000
1202754	H1243340-243200	24	38,0	1 1/2"	32	2	71,4	135,6	55,5	3000
1201982	H1243340-323200	32	51,0	2"	32	2	71,4	140,8	47,5	3000
1216874	H1243340-4040SL	40	63,0	2 1/2"	40	2 1/2	84,1	139,0	53,0	2500

// H1243360

60° Flange SAE 3000 psi J518 Code 61

SFL 60

Solid one piece

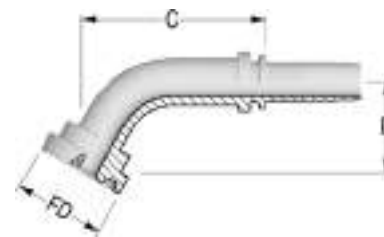

Item Code	Product Code	ID (Dash)	ID (mm)	ID (in)	F1 Dash	F1	FD (mm)	C (mm)	D Drop (mm)	WP (psi)
1216878	H1243360-121200	12	19,0	3/4"	12	3/4	38,1	85,7	37,0	5000
1216880	H1243360-161600	16	25,0	1"	16	1	44,5	101,0	47,0	5000
1216881	H1243360-162000	16	25,0	1"	20	1 1/4	50,8	106,6	43,5	4000
1216882	H1243360-202000	20	32,0	1 1/4"	20	1 1/4	50,8	129,5	56,5	4000
1202882	H1243360-242400	24	38,0	1 1/2"	24	1 1/2	60,3	151,5	57,0	3000
1216884	H1243360-323200	32	51,0	2"	32	2	71,4	173,0	92,0	3000

// H1243390

90° Flange SAE 3000 psi J518 Code 61

SFL 90

Solid one piece

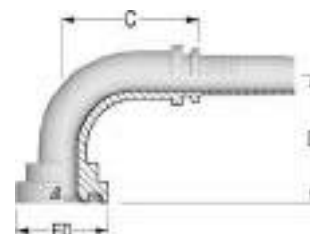

Item Code	Product Code	ID (Dash)	ID (mm)	ID (in)	F1 Dash	F1	FD (mm)	C (mm)	D Drop (mm)	WP (psi)
1202749	H1243390-080800	8	13,0	1/2"	8	1/2	30,2	45,8	42,0	5000
1202755	H1243390-081200	8	13,0	1/2"	12	3/4	38,1	45,3	51,0	5000
1202805	H1243390-101200	10	16,0	5/8"	12	3/4	38,1	49,4	51,0	5000
1202679	H1243390-121200	12	19,0	3/4"	12	3/4	38,1	59,7	58,0	5000
1202756	H1243390-121600	12	19,0	3/4"	16	1	44,5	66,2	64,5	5000
1202883	H1243390-122000	12	19,0	3/4"	20	1 1/4	50,8	69,7	60,0	4000
1202680	H1243390-161600	16	25,0	1"	16	1	44,5	70,6	67,0	5000
1201846	H1243390-162000	16	25,0	1"	20	1 1/4	50,8	73,6	71,0	4000
1216894	H1243390-162400	16	25,0	1"	24	1 1/2	60,3	93,1	75,0	3000
1202884	H1243390-201600	20	32,0	1 1/4"	16	1	44,5	94,4	65,0	5000
1201847	H1243390-202000	20	32,0	1 1/4"	20	1 1/4	50,8	88,0	84,0	4000
1202676	H1243390-202400	20	32,0	1 1/4"	24	1 1/2	60,3	91,5	87,5	3000
1202806	H1243390-242000	24	38,0	1 1/2"	20	1 1/4	50,8	93,6	93,0	4000
1202757	H1243390-242400	24	38,0	1 1/2"	24	1 1/2	60,3	104,8	91,0	3000
1202758	H1243390-243200	24	38,0	1 1/2"	32	2	71,4	104,8	115,0	3000
1216898	H1243390-322400	32	51,0	2"	24	1 1/2	60,3	132,8	133,0	3000
1201983	H1243390-323200	32	51,0	2"	32	2	71,4	129,3	130,0	3000
1203169	H1243390-3240B0	32	51,0	2"	40	2 1/2	84,1	103,0	100,0	2500
1203364	H1243390-4040SL	40	63,0	2 1/2"	40	2 1/2	84,1	137,2	125,0	2500

REV.2.1

// H1243610

Flange SAE 6000 psi J518 Code 62

SFS

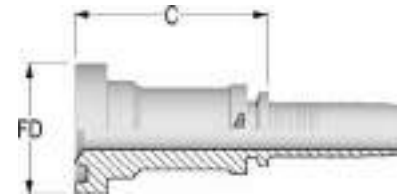

Item Code	Product Code	ID (Dash)	ID (mm)	ID (in)	F1 Dash	F1	C (mm)	FD (mm)	WP (psi)
1202511	H1243610-080800	8	13,0	1/2"	8	1/2	47,0	31,8	6000
1202759	H1243610-081200	8	13,0	1/2"	12	3/4	52,0	41,3	6000
1202807	H1243610-101200	10	16,0	5/8"	12	3/4	52,2	41,3	6000
1202733	H1243610-121200	12	19,0	3/4"	12	3/4	52,5	41,3	6000
1202760	H1243610-121600	12	19,0	3/4"	16	1	55,5	47,6	6000
1216908	H1243610-161200	16	25,0	1"	12	3/4	56,4	41,3	6000
1201415	H1243610-161600	16	25,0	1"	16	1	56,4	47,6	6000
1201416	H1243610-162000	16	25,0	1"	20	1 1/4	63,4	54,0	6000
1201417	H1243610-202000	20	32,0	1 1/4"	20	1 1/4	83,0	54,0	6000
1201418	H1243610-202400	20	32,0	1 1/4"	24	1 1/2	71,0	63,5	6000
1201419	H1243610-242400	24	38,0	1 1/2"	24	1 1/2	101,0	63,5	6000
1201420	H1243610-243200	24	38,0	1 1/2"	32	2	76,0	79,4	6000
1201421	H1243610-323200	32	51,0	2"	32	2	76,0	79,4	6000

// H1243640

45° Flange SAE 6000 psi J518 Code 62

SFS 45

Solid one piece



Item Code	Product Code	ID (Dash)	ID (mm)	ID (in)	F1 Dash	F1	FD (mm)	C (mm)	D Drop (mm)	WP (psi)
1201729	H1243640-080800	8	13,0	1/2"	8	1/2	31,8	56,5	23,0	6000
1202764	H1243640-081200	8	13,0	1/2"	12	3/4	41,3	79,9	30,5	6000
1216910	H1243640-101200	10	16,0	5/8"	12	3/4	41,3	69,0	31,0	6000
1202082	H1243640-121200	12	19,0	3/4"	12	3/4	41,3	84,1	31,0	6000
1202083	H1243640-121600	12	19,0	3/4"	16	1	47,6	80,0	33,5	6000
1201794	H1243640-161600	16	25,0	1"	16	1	47,6	96,7	36,0	6000
1202091	H1243640-162000	16	25,0	1"	20	1 1/4	54,0	96,1	39,0	6000
1202761	H1243640-202000	20	32,0	1 1/4"	20	1 1/4	54,0	108,6	40,0	6000
1202452	H1243640-202400	20	32,0	1 1/4"	24	1 1/2	63,5	114,8	45,5	6000
1202453	H1243640-242400	24	38,0	1 1/2"	24	1 1/2	63,5	122,9	45,0	6000
1202734	H1243640-323200	32	51,0	2"	32	2	79,4	156,6	60,0	6000

// H1243690

90° Flange SAE 6000 psi J518 Code 62

SFS 90

Solid one piece

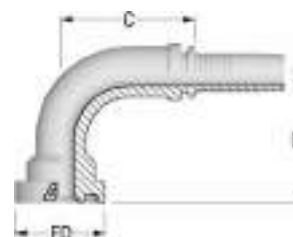

Item Code	Product Code	ID (Dash)	ID (mm)	ID (in)	F1 Dash	FD (mm)	C (mm)	D Drop (mm)	WP (psi)	F1
1202257	H1243690-080800	8	13,0	1/2"	8	31,8	47,8	46,0	6000	1/2
1202766	H1243690-081200	8	13,0	1/2"	12	41,3	47,8	54,0	6000	3/4
1202808	H1243690-100800	10	16,0	5/8"	8	31,8	50,0	52,0	6000	1/2
1202814	H1243690-101200	10	16,0	5/8"	12	41,3	49,9	55,0	6000	3/4
1202075	H1243690-121200	12	19,0	3/4"	12	41,3	63,2	61,0	6000	3/4
1201795	H1243690-121600	12	19,0	3/4"	16	47,6	63,2	66,0	6000	1
1216913	H1243690-161200	16	25,0	1"	12	41,3	72,6	61,0	6000	3/4
1201739	H1243690-161600	16	25,0	1"	16	47,6	73,6	75,0	6000	1
1202767	H1243690-162000	16	25,0	1"	20	54,0	77,6	78,0	6000	1 1/4
1202735	H1243690-202000	20	32,0	1 1/4"	20	54,0	94,5	89,0	6000	1 1/4
1202768	H1243690-202400	20	32,0	1 1/4"	24	63,5	98,0	94,0	6000	1 1/2
1202736	H1243690-242400	24	38,0	1 1/2"	24	63,5	99,6	105,0	6000	1 1/2
1202769	H1243690-243200	24	38,0	1 1/2"	32	79,4	116,9	123,0	6000	2
1202762	H1243690-323200	32	51,0	2"	32	79,4	143,3	132,0	6000	2

// H10W3320

Split Flange Clamp 3000 psi J518 Code 61

FHL



Item Code	Product Code	FD (in)	V (mm)	H (mm)
1900451	H10W3320-080000	1/2"	38,1	8,7
1900457	H10W3320-120000	3/4"	47,6	11,1
1900452	H10W3320-160000	1"	52,4	13,1
1900454	H10W3320-200000	1 1/4"	58,7	15,1
1900453	H10W3320-240000	1 1/2"	69,9	17,9
1900455	H10W3320-320000	2"	77,8	21,4
1900456	H10W3320-400000	2 1/2"	89,0	25,5
1900458	H10W3320-480000	3"	106,0	31,0
1901123	H10W3320-560000	3 1/2"	120,0	35,0
1900715	H10W3320-640000	4"	130,0	39,0

REV.2.1

// H10W3620

Split Flange Clamp 6000 psi J518 Code 62

FHS

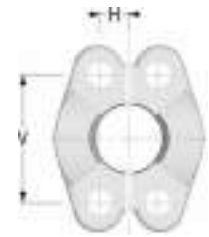

Item Code	Product Code	FD (in)	V (mm)	H (mm)
1900445	H10W3620-080000	1/2"	40,5	9,1
1900450	H10W3620-120000	3/4"	50,8	11,9
1900446	H10W3620-160000	1"	57,2	13,9
1900448	H10W3620-200000	1 1/4"	66,7	15,9
1900447	H10W3620-240000	1 1/2"	79,4	18,3
1900449	H10W3620-320000	2"	96,8	22,2

// H10W3310

4 Hole Flange Clamp 3000 psi J518 Code 61

VHL

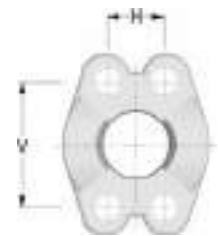

Item Code	Product Code	FD (in)	V (mm)	H (mm)
1900442	H10W3310-120000	3/4"	47,6	22,2
1900437	H10W3310-160000	1"	52,4	26,2
1900439	H10W3310-200000	1 1/4"	58,7	30,2
1900438	H10W3310-240000	1 1/2"	69,9	35,8
1900440	H10W3310-320000	2"	77,8	42,8

// H10W3610

4 Hole Flange Clamp 6000 psi J518 Code 62

VHS

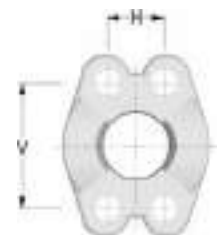

Item Code	Product Code	FD (in)	V (mm)	H (mm)
1900428	H10W3610-080000	1/2"	40,5	18,2
1900433	H10W3610-120000	3/4"	50,8	23,8
1900429	H10W3610-160000	1"	57,2	27,8
1900431	H10W3610-200000	1 1/4"	66,7	31,8
1900430	H10W3610-240000	1 1/2"	79,4	36,6
1900432	H10W3610-320000	2"	96,8	44,4
1900910	H10W3610-400000	2 1/2"	123,8	58,7



// NEW POWERTRAK FITTINGS

// BSP INSERTS.....	93	// ORFS INSERTS.....	100
// DIN METRIC INSERTS.....	95	// SAE FLANGES.....	102
// JIC 37° INSERTS.....	97	// SUPERCAT FLANGES.....	105
// NPTF INSERTS.....	99	// FERRULES.....	106

REV.2.1

// BSP INSERTS

// H1310510

BSP Male 60° Flare
AGR

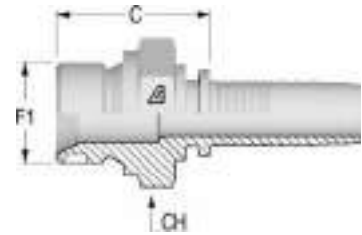

Item Code	Product Code	ID (Dash)	ID (mm)	ID (in)	F1 Dash	F1	C (mm)	CH (mm)
1238090	H1310510-121200	12	19,0	3/4"	12	3/4-14	37,5	32,0
1226162	H1310510-161600	16	25,0	1"	16	1-11	44,5	41,0
1230555	H1310510-202000	20	32,0	1 1/4"	20	1 1/4-11	95,5	50,0
1241600	H1310510-242400	24	38,0	1 1/2"	24	1 1/2-11	56,0	55,0
1241601	H1310510-323200	32	51,0	2"	32	2-11	71,5	70,0

// H1320812

BSP Female 60° Cone with O-Ring
DKOR

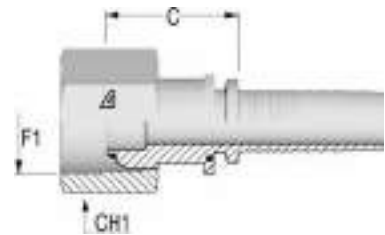

Item Code	Product Code	Nut Type	ID (Dash)	ID (mm)	ID (in)	F1 Dash	F1	C (mm)	CH1 (mm)
1226178	H1320812-121200	Thrust wire nut	12	19,0	3/4"	12	3/4-14	25,2	32,0
1241616	H1320812-121600	Thrust wire nut	12	19,0	3/4"	16	1-11	27,7	38,0
1226179	H1320812-161600	Thrust wire nut	16	25,0	1"	16	1-11	31,0	38,0
1241617	H1320812-162000	Thrust wire nut	16	25,0	1"	20	1 1/4-11	32,0	50,0
1238241	H1320812-202000	Thrust wire nut	20	32,0	1 1/4"	20	1 1/4-11	35,0	50,0
1246639	H1320812-202400	Thrust wire nut	20	32,0	1 1/4"	24	1 1/2-11	36,8	55,0
1239857	H1320812-242400	Thrust wire nut	24	38,0	1 1/2"	24	1 1/2-11	38,8	55,0
1238240	H1320812-323200	Thrust wire nut	32	51,0	2"	32	2-11	49,0	70,0

// H1320842

45° BSP Female 60° Cone with O-Ring
DKOR 45
Solid one piece

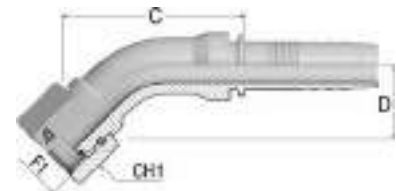

Item Code	Product Code	Nut Type	ID (Dash)	ID (mm)	ID (in)	F1 Dash	F1	C (mm)	D Drop (mm)	CH1 (mm)
1241628	H1320842-121200	Thrust wire nut	12	19,0	3/4"	12	3/4-14	75,0	30,0	32,0
1237423	H1320842-161600	Thrust wire nut	16	25,0	1"	16	1-11	92,0	40,0	38,0
1241629	H1320842-202000	Thrust wire nut	20	32,0	1 1/4"	20	1 1/4-11	90,0	40,0	50,0
1242138	H1320842-242400	Thrust wire nut	24	38,0	1 1/2"	24	1 1/2-11	116,0	46,0	55,0
1241630	H1320842-323200	Thrust wire nut	32	51,0	2"	32	2-11	153,5	60,0	70,0

// H1320892

90° BSPP Female 60° Cone with O-Ring

DKOR 90

Solid one piece



Item Code	Product Code	Nut Type	ID (Dash)	ID (mm)	ID (in)	F1 Dash	F1	C (mm)	D Drop (mm)	CH1 (mm)
1226180	H1320892-121200	Thrust wire nut	12	19,0	3/4"	12	3/4-14	59,0	61,0	32,0
1226181	H1320892-161600	Thrust wire nut	16	25,0	1"	16	1-11	74,0	71,0	38,0
1241625	H1320892-202000	Thrust wire nut	20	32,0	1 1/4"	20	1 1/4-11	84,0	83,0	50,0
1238242	H1320892-242400	Thrust wire nut	24	38,0	1 1/2"	24	1 1/2-11	101,0	96,0	55,0
1241626	H1320892-323200	Thrust wire nut	32	51,0	2"	32	2-11	140,5	130,0	70,0

REV.2.1

// DIN METRIC INSERTS

// H1311210

Metric Male 24° Seat
DIN 3853 - Heavy Series
CES

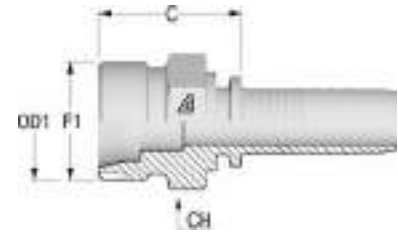

Item Code	Product Code	ID (Dash)	ID (mm)	ID (in)	F1	OD1	C (mm)	CH (mm)
1241605	H1311210-123600	12	19,0	3/4"	M36X2	25	36,5	36,0
1226164	H1311210-164200	16	25,0	1"	M42X2	30	36,2	46,0
1243063	H1311210-204200	20	32,0	1 1/4"	M42X2	30	47,0	46,0
1226165	H1311210-205200	20	32,0	1 1/4"	M52X2	38	51,0	55,0

// H1321613

Metric Female 24° Cone with O-Ring
DIN 3865 - Heavy Series
DKOS

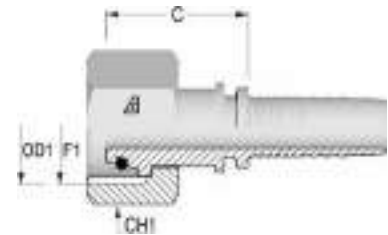

Item Code	Product Code	Nut Type	ID (Dash)	ID (mm)	ID (in)	F1	OD1	C (mm)	CH1 (mm)
1226182	H1321612-123000	Thrust wire nut	12	19,0	3/4"	M30X2	20	36,8	36,0
1241632	H1321613-123600	Slip on nut	12	19,0	3/4"	M36X2	25	41,1	46,0
1240224	H1321612-163600	Thrust wire nut	16	25,0	1"	M36X2	25	46,0	46,0
1226184	H1321613-164200	Slip on nut	16	25,0	1"	M42X2	30	45,2	50,0
1242139	H1321612-204200	Thrust wire nut	20	32,0	1 1/4"	M42X2	30	51,0	50,0
1226185	H1321613-205200	Slip on nut	20	32,0	1 1/4"	M52X2	38	51,1	60,0
1238244	H1321612-245200	Thrust wire nut	24	38,0	1 1/2"	M52X2	38	58,0	60,0

Image: insert with Slip on Nut.

// H1321643

45° Metric Female 24° Cone with O-Ring

DIN 3865 - Heavy Series

DKOS 45

Solid one piece

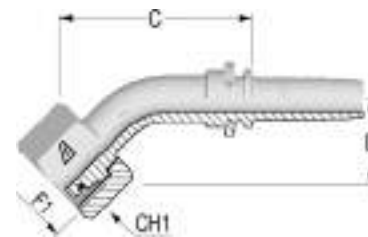

Item Code	Product Code	Nut Type	ID (Dash)	ID (mm)	ID (in)	F1	OD1	C (mm)	D Drop (mm)	CH1 (mm)
1243201	H1321643-123000	Slip on nut	12	19,0	3/4"	M30X2	20	66,0	29,0	36,0
1237408	H1321643-123600	Slip on nut	12	19,0	3/4"	M36X2	25	70,4	33,0	46,0
1242140	H1321642-163600	Thrust wire nut	16	25,0	1"	M36X2	25	93,0	37,5	46,0
1237422	H1321643-164200	Slip on nut	16	25,0	1"	M42X2	30	109,5	35,5	50,0
1238246	H1321643-205200	Slip on nut	20	32,0	1 1/4"	M52X2	38	112,0	45,0	60,0
1238245	H1321642-245200	Thrust wire nut	24	38,0	1 1/2"	M52X2	38	127,0	45,0	60,0

Image: insert with Slip on Nut.

// H1321693

90° Metric Female 24° Cone with O-Ring

DIN 3865 - Heavy Series

DKOS 90

Solid one piece

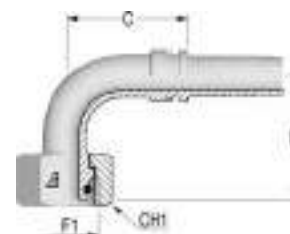

Item Code	Product Code	Nut Type	ID (Dash)	ID (mm)	ID (in)	F1	OD1	C (mm)	D Drop (mm)	CH1 (mm)
1241633	H1321692-123000	Thrust wire nut	12	19,0	3/4"	M30X2	20	65,5	67,5	36,0
1237409	H1321693-123600	Slip on nut	12	19,0	3/4"	M36X2	25	51,0	59,5	46,0
1240225	H1321692-163600	Thrust wire nut	16	25,0	1"	M36X2	25	75,6	82,0	46,0
1237410	H1321693-164200	Slip on nut	16	25,0	1"	M42X2	30	85,0	70,0	50,0
1243064	H1321692-204200	Thrust wire nut	20	32,0	1 1/4"	M42X2	30	88,0	87,5	50,0
1238248	H1321693-205200	Slip on nut	20	32,0	1 1/4"	M52X2	38	97,0	92,0	60,0
1238247	H1321692-245200	Thrust wire nut	24	38,0	1 1/2"	M52X2	38	106,0	95,0	60,0

Image: insert with Slip on Nut.

REV.2.1

// JIC 37° INSERTS

// H1312510

JIC Male 37° Cone
AGJ

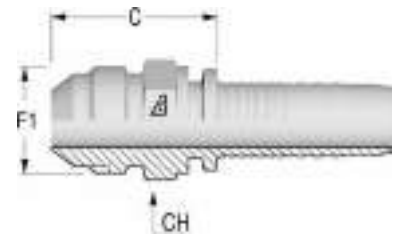

Item Code	Product Code	ID (Dash)	ID (mm)	ID (in)	F1 Dash	F1	C (mm)	CH (mm)
1226168	H1312510-121200	12	19,0	3/4"	12	1 1/16-12	38,5	27,0
1226169	H1312510-161600	16	25,0	1"	16	1 5/16-12	45,5	36,0
1226170	H1312510-202000	20	32,0	1 1/4"	20	1 5/8-12	51,5	46,0
1226171	H1312510-242400	24	38,0	1 1/2"	24	1 7/8-12	57,5	50,0
1238091	H1312510-323200	32	51,0	2"	32	2 1/2-12	77,0	65,0

// H1322512

JIC Female 37° Seat
DKJ

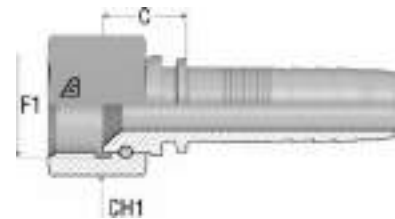

Item Code	Product Code	Nut Type	ID (Dash)	ID (mm)	ID (in)	F1 Dash	F1	C (mm)	CH1 (mm)
1241618	H1322512-121200	Thrust wire nut	12	19,0	3/4"	12	1 1/16-12	22,2	32,0
1241619	H1322512-121600	Thrust wire nut	12	19,0	3/4"	16	1 5/16-12	25,0	38,0
1241620	H1322512-161600	Thrust wire nut	16	25,0	1"	16	1 5/16-12	27,0	38,0
1241621	H1322512-162000	Thrust wire nut	16	25,0	1"	20	1 5/8-12	29,0	50,0
1241622	H1322512-202000	Thrust wire nut	20	32,0	1 1/4"	20	1 5/8-12	31,5	50,0
1241623	H1322512-202400	Thrust wire nut	20	32,0	1 1/4"	24	1 7/8-12	34,0	55,0
1241624	H1322512-242400	Thrust wire nut	24	38,0	1 1/2"	24	1 7/8-12	36,5	55,0

// H1322542

45° JIC Female 37° Seat
Medium Drop
DKJ 45M
Solid one piece

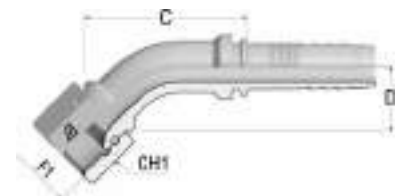

Item Code	Product Code	Nut Type	ID (Dash)	ID (mm)	ID (in)	F1 Dash	F1	C (mm)	D Drop (mm)	CH1 (mm)
1226205	H1322542-121200	Thrust wire nut	12	19,0	3/4"	12	1 1/16-12	69,5	27,5	32,0
1241631	H1322542-121600	Thrust wire nut	12	19,0	3/4"	16	1 5/16-12	69,0	33,5	38,0
1226206	H1322542-161600	Thrust wire nut	16	25,0	1"	16	1 5/16-12	84,8	31,0	38,0
1238251	H1322542-202000	Thrust wire nut	20	32,0	1 1/4"	20	1 5/8-12	99,0	37,0	50,0
1226207	H1322542-242400	Thrust wire nut	24	38,0	1 1/2"	24	1 7/8-12	118,3	43,5	55,0

// H1322592
90° JIC Female 37° Seat
Medium Drop
DKJ 90M
Solid one piece

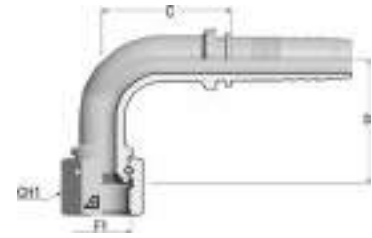

Item Code	Product Code	Nut Type	ID (Dash)	ID (mm)	ID (in)	F1 Dash	F1	C (mm)	D Drop (mm)	CH1 (mm)
1226209	H1322592-121200	Thrust wire nut	12	19,0	3/4"	12	1 1/16-12	59,1	57,0	32,0
1226211	H1322592-121600	Thrust wire nut	12	19,0	3/4"	16	1 5/16-12	58,1	63,5	38,0
1226212	H1322592-161600	Thrust wire nut	16	25,0	1"	16	1 5/16-12	75,7	67,0	38,0
1238254	H1322592-202000	Thrust wire nut	20	32,0	1 1/4"	20	1 5/8-12	84,0	78,0	50,0
1230690	H1322592-242400	Thrust wire nut	24	38,0	1 1/2"	24	1 7/8-12	105,3	92,0	55,0
1238255	H1322592-323200	Thrust wire nut	32	51,0	2"	32	2 1/2-12	147,5	135,0	70,0

REV.2.1

// NPTF INSERTS

// H1312810

NPTF Male 60° Seat
AGN

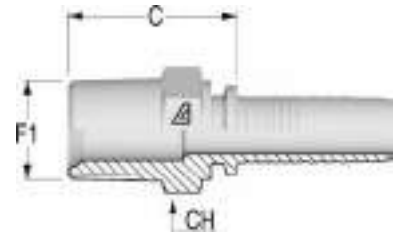

Item Code	Product Code	ID (Dash)	ID (mm)	ID (in)	F1 Dash	F1	C (mm)	CH (mm)
1226172	H1312810-121200	12	19,0	3/4"	12	3/4-14	35,5	27,0
1226173	H1312810-161600	16	25,0	1"	16	1-11 1/2	46,5	36,0
1238093	H1312810-202000	20	32,0	1 1/4"	20	1 1/4-11 1/2	41,0	46,0
1238095	H1312810-323200	32	51,0	2"	32	2-11 1/2	69,2	65,0

// ORFS INSERTS

// H1312410

ORFS Male

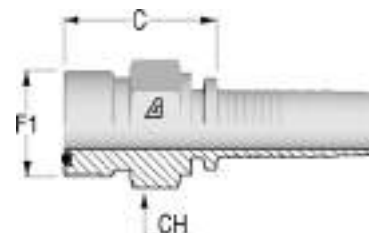

Item Code	Product Code	ID (Dash)	ID (mm)	ID (in)	F1 Dash	F1	C (mm)	CH (mm)
1230556	H1312410-121200	12	19,0	3/4"	12	1 3/16-12	32,7	32,0
1226166	H1312410-161600	16	25,0	1"	16	1 7/16-12	35,7	38,0
1230557	H1312410-202000	20	32,0	1 1/4"	20	1 11/16-12	38,7	46,0
1226167	H1312410-242400	24	38,0	1 1/2"	24	2-12	41,8	55,0

// H1322411

ORFS Female with Stem Hexagon

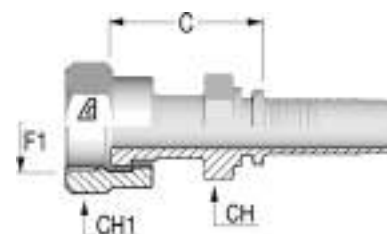

Item Code	Product Code	Nut Type	ID (Dash)	ID (mm)	ID (in)	F1 Dash	F1	C (mm)	CH (mm)	CH1 (mm)
1226190	H1322411-121200	Crimped	12	19,0	3/4"	12	1 3/16-12	44,5	30,0	36,0
1226191	H1322411-121600	Crimped	12	19,0	3/4"	16	1 7/16-12	50,5	36,0	41,0
1242141	H1322411-161200	Crimped	16	25,0	1"	12	1 3/16-12	42,0	32,0	36,0
1226192	H1322411-161600	Crimped	16	25,0	1"	16	1 7/16-12	52,5	36,0	41,0
1226193	H1322411-162000	Crimped	16	25,0	1"	20	1 11/16-12	53,5	41,0	50,0
1226194	H1322411-202000	Crimped	20	32,0	1 1/4"	20	1 11/16-12	56,0	41,0	50,0
1226195	H1322411-242400	Crimped	24	38,0	1 1/2"	24	2-12	62,5	50,0	60,0

// H1322441

45° ORFS Female

Medium Drop

DK ORFS 45M

Solid one piece

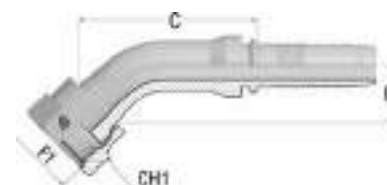

Item Code	Product Code	Nut Type	ID (Dash)	ID (mm)	ID (in)	F1 Dash	F1	C (mm)	D Drop (mm)	CH1 (mm)
1226196	H1322441-121200	Crimped	12	19,0	3/4"	12	1 3/16-12	32,5	26,0	36,0
1226197	H1322441-121600	Crimped	12	19,0	3/4"	16	1 7/16-12	31,2	28,0	41,0
1226198	H1322441-161600	Crimped	16	25,0	1"	16	1 7/16-12	94,0	28,0	41,0
1241634	H1322441-162000	Crimped	16	25,0	1"	20	1 11/16-12	88,0	28,0	50,0
1238249	H1322441-202000	Crimped	20	32,0	1 1/4"	20	1 11/16-12	110,0	36,5	50,0

REV.2.1

// H1322491
90° ORFS Female
Medium Drop
DK ORFS 90M
Solid one piece

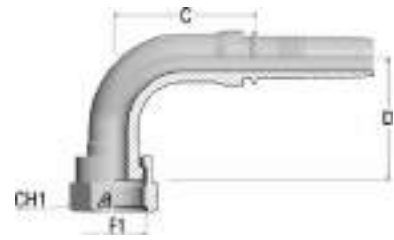

Item Code	Product Code	Nut Type	ID (Dash)	ID (mm)	ID (in)	F1 Dash	F1	C (mm)	D Drop (mm)	CH1 (mm)
1226200	H1322491-121200	Crimped	12	19,0	3/4"	12	1 3/16-12	67,6	58,0	36,0
1226201	H1322491-121600	Crimped	12	19,0	3/4"	16	1 7/16-12	69,6	58,0	36,0
1226202	H1322491-161600	Crimped	16	25,0	1"	16	1 7/16-12	79,6	66,0	41,0
1241635	H1322491-162000	Crimped	16	25,0	1"	20	1 11/16-12	73,0	66,0	50,0
1226203	H1322491-202000	Crimped	20	32,0	1 1/4"	20	1 11/16-12	102,4	81,0	50,0

// SAE FLANGES

// H1343310

Flange SAE 3000 psi J518 Code 61
SFL

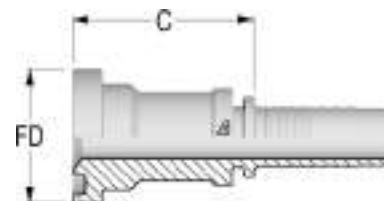

Item Code	Product Code	ID (Dash)	ID (mm)	ID (in)	F1 Dash	F1	C (mm)	FD (mm)	WP (psi)
1226222	H1343310-121200	12	19,0	3/4"	12	3/4	43,5	38,1	5000
1226224	H1343310-161600	16	25,0	1"	16	1	53,5	44,5	5000
1226225	H1343310-162000	16	25,0	1"	20	1 1/4	56,0	50,8	5000
1241602	H1343310-201600	20	32,0	1 1/4"	16	1	58,5	44,4	5000
1226227	H1343310-202000	20	32,0	1 1/4"	20	1 1/4	58,5	50,8	5000
1241604	H1343310-202400	20	32,0	1 1/4"	24	1 1/2	61,5	60,3	5000
1241603	H1343310-242000	24	38,0	1 1/2"	20	1 1/4	55,5	50,8	5000
1226228	H1343310-242400	24	38,0	1 1/2"	24	1 1/2	63,5	60,3	5000
1226229	H1343310-243200	24	38,0	1 1/2"	32	2	75,0	71,4	5000
1235374	H1343310-323200	32	50,0	2"	32	2	85,0	71,4	5000

// H1343340

45° Flange SAE 3000 psi J518 Code 61
SFL 45
Solid one piece

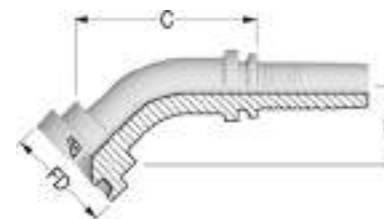

Item Code	Product Code	ID (Dash)	ID (mm)	ID (in)	F1 Dash	F1	FD (mm)	C (mm)	D Drop (mm)	WP (psi)
1226233	H1343340-162000	16	25,0	1"	20	1 1/4	50,8	88,9	32,5	5000
1226234	H1343340-202000	20	32,0	1 1/4"	20	1 1/4	50,8	94,3	38,5	5000
1226235	H1343340-242400	24	38,0	1 1/2"	24	1 1/2	60,3	99,8	43,0	5000
1233534	H1343340-323200	32	50,0	2"	32	2	71,4	154,0	54,0	5000

REV.2.1

// H1343390

90° Flange SAE 3000 psi J518 Code 61

SFL 90

Solid one piece

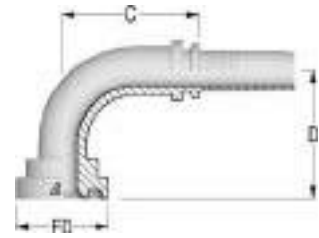

Item Code	Product Code	ID (Dash)	ID (mm)	ID (in)	F1 Dash	F1	FD (mm)	C (mm)	D Drop (mm)	WP (psi)
1226241	H1343390-161600	16	25,0	1"	16	1	44,5	78,1	64,0	5000
1226242	H1343390-162000	16	25,0	1"	20	1 1/4	50,8	74,7	69,0	5000
1226244	H1343390-202000	20	32,0	1 1/4"	20	1 1/4	50,8	92,0	81,0	5000
1241608	H1343390-202400	20	32,0	1 1/4"	24	1 1/2	60,3	87,0	85,0	5000
1226245	H1343390-242400	24	38,0	1 1/2"	24	1 1/2	60,3	103,0	93,0	5000
1235375	H1343390-323200	32	50,0	2"	32	2	71,4	139,0	130,0	5000

// H1343610

Flange SAE 6000 psi J518 Code 62

SFS

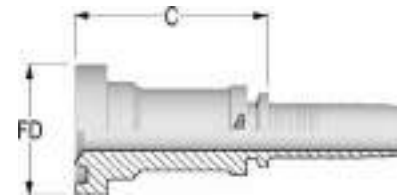

Item Code	Product Code	ID (Dash)	ID (mm)	ID (in)	F1 Dash	F1	C (mm)	FD (mm)	WP (psi)
1226247	H1343610-121200	12	19,0	3/4"	12	3/4	53,5	41,3	6000
1226248	H1343610-121600	12	19,0	3/4"	16	1	56,5	47,6	6000
1226623	H1343610-161200	16	25,0	1"	12	3/4	58,5	41,3	6000
1226250	H1343610-161600	16	25,0	1"	16	1	58,5	47,6	6000
1226624	H1343610-162000	16	25,0	1"	20	1 1/4	65,5	54,0	6000
1236992	H1343610-201600	20	32,0	1 1/4"	16	1	61,0	47,6	6000
1226252	H1343610-202000	20	32,0	1 1/4"	20	1 1/4	64,0	54,0	6000
1226253	H1343610-202400	20	32,0	1 1/4"	24	1 1/2	74,0	63,5	6000
1241614	H1343610-242000	24	38,0	1 1/2"	20	1 1/4	71,0	54,0	6000
1226254	H1343610-242400	24	38,0	1 1/2"	24	1 1/2	76,0	63,5	6000
1226255	H1343610-243200	24	38,0	1 1/2"	32	2	88,0	79,4	6000
1241615	H1343610-322400	32	51,0	2"	24	1 1/2	86,0	63,5	6000
1235378	H1343610-323200	32	50,0	2"	32	2	103,0	79,4	6000

// H1343640

45° Flange SAE 6000 psi J518 Code 62

SFS 45

Solid one piece



Item Code	Product Code	ID (Dash)	ID (mm)	ID (in)	F1 Dash	F1	FD (mm)	C (mm)	D Drop (mm)	WP (psi)
1226261	H1343640-121200	12	19,0	3/4"	12	3/4	41,3	62,8	30,0	6000
1226262	H1343640-121600	12	19,0	3/4"	16	1	47,6	65,4	33,0	6000
1241609	H1343640-161200	16	25,0	1"	12	3/4	41,3	77,0	29,5	6000
1226263	H1343640-161600	16	25,0	1"	16	1	47,6	82,9	38,5	6000
1226264	H1343640-162000	16	25,0	1"	20	1 1/4	54,0	78,0	44,0	6000
1242142	H1343640-201600	20	32,0	1 1/4"	16	1	47,6	104,7	34,5	6000
1238305	H1343640-202000	20	32,0	1 1/4"	20	1 1/4	54,0	103,0	41,0	6000
1241610	H1343640-202400	20	32,0	1 1/4"	24	1 1/2	63,5	117,0	48,0	6000
1226265	H1343640-242400	24	38,0	1 1/2"	24	1 1/2	63,5	122,5	48,0	6000
1235379	H1343640-323200	32	50,0	2"	32	2	79,4	177,0	61,0	6000

// H1343690

90° Flange SAE 6000 psi J518 Code 62

SFS 90

Solid one piece

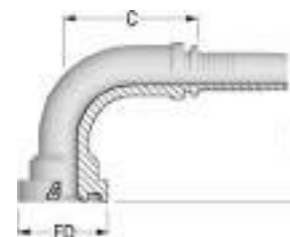

Item Code	Product Code	ID (Dash)	ID (mm)	ID (in)	F1 Dash	F1	FD (mm)	C (mm)	D Drop (mm)	WP (psi)
1226270	H1343690-121200	12	19,0	3/4"	12	3/4	41,3	64,7	64,0	6000
1226271	H1343690-121600	12	19,0	3/4"	16	1	47,6	64,7	66,0	6000
1226633	H1343690-161200	16	25,0	1"	12	3/4	41,3	74,7	61,0	6000
1226273	H1343690-161600	16	25,0	1"	16	1	47,6	74,8	74,0	6000
1226274	H1343690-162000	16	25,0	1"	20	1 1/4	54,0	78,8	85,0	6000
1241611	H1343690-201600	20	32,0	1 1/4"	16	1	47,6	87,0	72,0	6000
1230765	H1343690-202000	20	32,0	1 1/4"	20	1 1/4	54,0	96,0	91,0	6000
1238310	H1343690-202400	20	32,0	1 1/4"	24	1 1/2	63,5	99,0	103,5	6000
1226276	H1343690-242400	24	38,0	1 1/2"	24	1 1/2	63,5	113,8	109,0	6000
1235381	H1343690-323200	32	50,0	2"	32	2	79,4	169,0	134,0	6000

// SUPERCAT FLANGES

// H1343910

Flange SUPERCAT

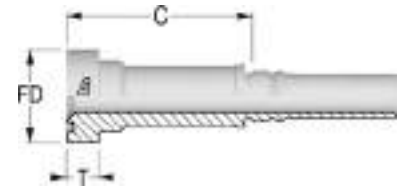

Item Code	Product Code	ID (Dash)	ID (mm)	ID (in)	F1 Dash	F1	FD (mm)	T (mm)	C (mm)
1226278	H1343910-121200	12	19,0	3/4"	12	3/4	41,3	14,3	85,5
1226279	H1343910-121600	12	19,0	3/4"	16	1	47,6	14,3	85,5
1226280	H1343910-161600	16	25,0	1"	16	1	47,6	14,3	94,5
1226281	H1343910-162000	16	25,0	1"	20	1 1/4	54,0	14,3	94,5
1226282	H1343910-202000	20	32,0	1 1/4"	20	1 1/4	54,0	14,3	92,0
1226283	H1343910-202400	20	32,0	1 1/4"	24	1 1/2	63,5	14,3	87,0

// H1343940

45° Flange SUPERCAT

Solid one piece

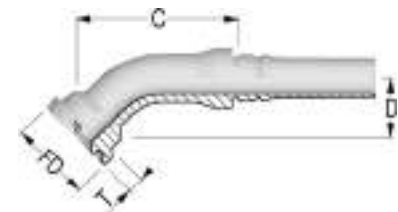

Item Code	Product Code	ID (Dash)	ID (mm)	ID (in)	F1 Dash	F1	FD (mm)	T (mm)	C (mm)	D Drop (mm)
1226289	H1343940-121200	12	19,0	3/4"	12	3/4	41,3	14,3	107,0	34,0
1241612	H1343940-121600	12	19,0	3/4"	16	1	47,6	14,3	112,0	34,0
1226290	H1343940-161600	16	25,0	1"	16	1	47,6	14,3	129,0	42,5
1226291	H1343940-162000	16	25,0	1"	20	1 1/4	54,0	14,3	128,0	40,0
1226292	H1343940-202000	20	32,0	1 1/4"	20	1 1/4	54,0	14,3	150,0	45,1
1238317	H1343940-202400	20	32,0	1 1/4"	24	1 1/2	63,5	14,3	152,0	60,0

// H1343990

90° Flange SUPERCAT

Solid one piece



Item Code	Product Code	ID (Dash)	ID (mm)	ID (in)	F1 Dash	F1	FD (mm)	T (mm)	C (mm)	D Drop (mm)
1226297	H1343990-121200	12	19,0	3/4"	12	3/4	41,3	14,3	67,2	67,0
1226298	H1343990-121600	12	19,0	3/4"	16	1	47,6	14,3	68,7	70,0
1226299	H1343990-161600	16	25,0	1"	16	1	47,6	14,3	84,8	79,0
1226301	H1343990-162000	16	25,0	1"	20	1 1/4	54,0	14,3	79,8	82,5
1238312	H1343990-202000	20	32,0	1 1/4"	20	1 1/4	54,0	14,3	97,0	93,0
1238315	H1343990-202400	20	32,0	1 1/4"	24	1 1/2	63,5	14,3	97,0	101,0

// FERRULES

// H1300NS4

Multispiral No-Skive Ferrule for 4 Spiral Hoses

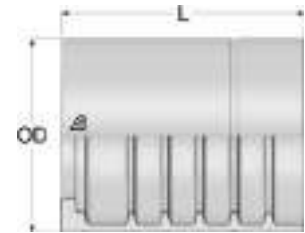

Item Code	Product Code	ID (Dash)	ID (mm)	ID (in)	Ferrule OD (mm)	L (mm)
1236599	H1300NS4-120000	12	19,0	3/4"	44,0	55,0
1236600	H1300NS4-160000	16	25,0	1"	51,0	64,0
1236601	H1300NS4-200000	20	31,0	1 1/4"	61,0	99,0
1236602	H1300NS4-240000	24	38,0	1 1/2"	70,0	89,5
1236603	H1300NS4-320000	32	51,0	2"	87,0	125,0

// H1300NS6

Multispiral No-Skive Ferrule for 6 Spiral Hoses

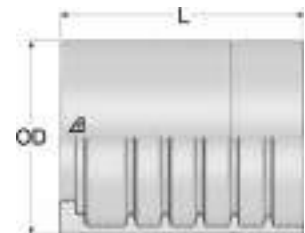

Item Code	Product Code	ID (Dash)	ID (mm)	ID (in)	Ferrule OD (mm)	L (mm)
1236604	H1300NS6-200000	20	31,0	1 1/4"	65,0	99,0
1236605	H1300NS6-240000	24	38,0	1 1/2"	73,0	89,5
1236606	H1300NS6-320000	32	51,0	2"	88,9	125,0



// WATERBLAST FITTINGS

// FERRULES	108	// INSERTS	109
-------------	-----	------------	-----

// FERRULES

// D990000 - WATERBLAST

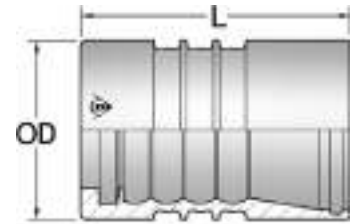

Item Code	Product Code	ID (Dash)	ID (mm)	ID (in)	Ferrule OD (mm)	L (mm)
1240103	D99000H-04/0	4	6,0	1/4"	22,0	25,5
1240105	D99000H-05/0	5	8,0	5/16"	27,0	35,0
1215264	D990000-06/0	6	10,0	3/8"	28,0	47,0
1223163	D99000N-08/0	8	13,0	1/2"	33,0	50,0
1215266	D990000-12/0	12	19,0	3/4"	41,0	63,0
1215267	D990000-16/0	16	25,0	1"	49,0	75,0

WB20L: 1/4" and 5/16" only

// D980000 - WATERBLAST

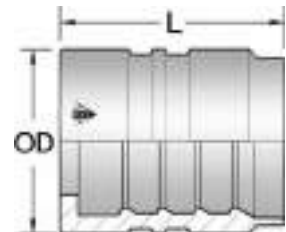

Item Code	Product Code	ID (Dash)	ID (mm)	ID (in)	Ferrule OD (mm)	L (mm)
1242379	D980000-06/0	6	10,0	3/8"	32,0	45,0
1215257	D980000-08/0	8	13,0	1/2"	37,4	46,0
1241935	D980000-12/0	12	19,0	3/4"	46,0	63,0

REV.2.1

// INSERTS

// D99001-WB

BSP Female 60° with O-Ring

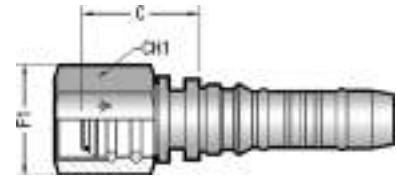

Item Code	Product Code	Nut Type	ID (Dash)	ID (mm)	ID (in)	F1 Dash	F1	C (mm)	CH1 (mm)
1240158	DA99001-0404/0	Slip on nut	4	6,0	1/4"	4	1/4-19	26,0	22,0
1240159	DA99001-0605/0	Slip on nut	5	8,0	5/16"	6	3/8-19	31,0	25,0
1214925	DA99001-0606/0	Thrust wire nut	6	10,0	3/8"	6	3/8-19	32,1	22,0
1225828	DA9900N-0808/0	Thrust wire nut	8	13,0	1/2"	8	1/2-14	36,0	30,0
1214927	DA99001-1212/0	Thrust wire nut	12	19,0	3/4"	12	3/4-14	37,3	36,0

// D99010-WB

BSP Female 60° without O-Ring

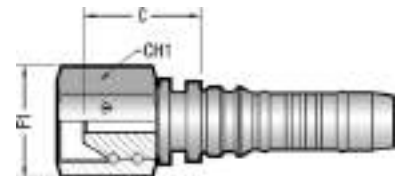

Item Code	Product Code	Nut Type	ID (Dash)	ID (mm)	ID (in)	F1 Dash	F1	C (mm)	CH1 (mm)
1245682	DA99010-0808/0	Thrust wire nut	8	13,0	1/2"	8	1/2-14	36,0	30,0

// D99061-WB

UNF Type "M Swivel"

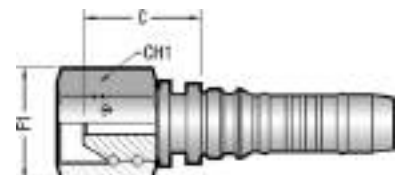

Item Code	Product Code	Nut Type	ID (Dash)	ID (mm)	ID (in)	F1 Dash	F1	C (mm)	CH1 (mm)
1230563	DA99061-1008/0	Thrust wire nut	8	13,0	1/2"	10	1-12 UNF	41,0	32,0

// D99179-WB

Metric Female 24° Cone with O-Ring - Heavy Series
DIN 3865 - DKOS -
Slip on Nut with Relief Bore

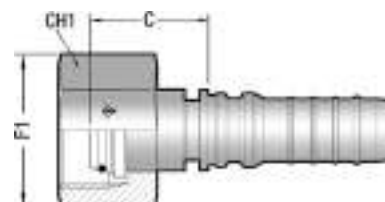

Item Code	Product Code	Nut Type	ID (Dash)	ID (mm)	ID (in)	F1	OD1	C (mm)	CH1 (mm)
1240100	DA99179-0204/0	Slip on nut	4	6,0	1/4"	M14X1.5	6	28,0	22,0
1240101	DA99179-0405/0	Slip on nut	5	8,0	5/16"	M18X1.5	10	34,3	27,0
1214929	DA99179-0606/0	Slip on nut	6	10,0	3/8"	M22X1.5	14	36,5	27,0
1214930	DA99179-0806/0	Slip on nut	6	10,0	3/8"	M24X1.5	16	39,5	30,0
1214931	DA9917N-0808/0	Slip on nut	8	13,0	1/2"	M24X1.5	16	40,0	30,0
1214932	DA99179-1212/0	Slip on nut	12	19,0	3/4"	M36X2	25	47,3	46,0
1214933	DA99179-1616/0	Slip on nut	16	25,0	1"	M42X2	30	49,6	50,0

// D99170-WB

NPTF Male 60° Seat - AGN

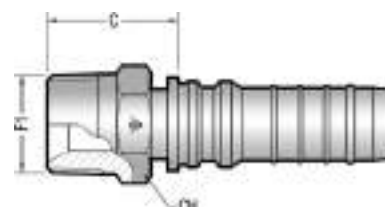

Item Code	Product Code	ID (Dash)	ID (mm)	ID (in)	F1 Dash	F1	C (mm)	CH (mm)
1240134	D990170-0404/0	4	6,0	1/4"	4	1/4-18	27,5	17,0
1240135	D990170-0605/0	5	8,0	5/16"	6	3/8-18	30,5	19,0
1215271	D990170-0606/0	6	10,0	3/8"	6	3/8-18	31,0	19,0
1215272	D99017N-0808/0	8	13,0	1/2"	8	1/2-14	35,0	22,0
1215273	D990170-1212/0	12	19,0	3/4"	12	3/4-14	37,9	30,0
1215274	D990170-1616/0	16	25,0	1"	16	1-11 1/2	47,3	36,0



// INTERLOCK FITTINGS

// FERRULES.....	112	// NPTF INSERTS.....	120
// HOSE MENDER.....	113	// ORFS INSERTS.....	121
// BSP INSERTS.....	114	// SAE FLANGES.....	123
// DIN METRIC INSERTS.....	116	// SUPERCAT FLANGES.....	127
// JIC 37° INSERTS.....	118	// HAMMER UNION.....	128

// FERRULES

// H1400200

Interlock Dual Skive Ferrule for 4 Spiral Hoses

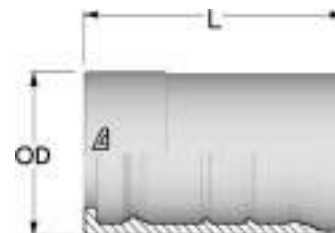

Item Code	Product Code	ID (Dash)	ID (mm)	ID (in)	Ferrule OD (mm)	L (mm)
1201571	H1400200-060000	6	10,0	3/8"	27,0	49,0
1201856	H1400200-080000	8	13,0	1/2"	30,0	52,5
1201502	H1400200-100000	10	16,0	5/8"	34,0	57,5
1201503	H1400200-120000	12	19,0	3/4"	38,0	60,2
1201504	H1400200-160000	16	25,0	1"	46,0	74,7
1200098	H1400200-200000	20	31,0	1 1/4"	55,0	88,2
1200099	H1400200-240000	24	38,0	1 1/2"	62,0	94,2
1201284	H1400200-320000	32	51,0	2"	78,0	99,2

// H1400301

Interlock Dual Skive Ferrule for 4-6 Spiral Hoses

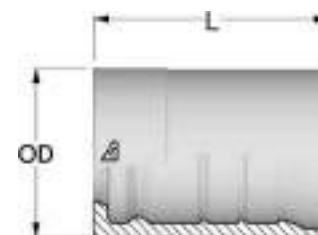

Item Code	Product Code	ID (Dash)	ID (mm)	ID (in)	Ferrule OD (mm)	L (mm)
1202585	H1400301-100000	10	16,0	5/8"	35,5	57,5
1202730	H1400301-120000	12	19,0	3/4"	43,5	60,0
1202222	H1400301-160000	16	25,0	1"	52,0	75,0
1201761	H1400301-200000	20	31,0	1 1/4"	62,0	88,0
1201805	H1400301-240000	24	38,0	1 1/2"	69,5	94,0
1202006	H1400301-320000	32	51,0	2"	88,0	99,0

// H1T00600

Interlock Dual Skive Ferrule for Alfabiotech/Powerflexbio 3K and AT8K

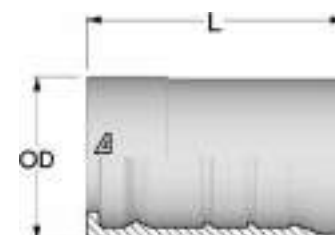

Item Code	Product Code	ID (Dash)	ID (mm)	ID (in)	Ferrule OD (mm)	L (mm)
1225872	H1T00600-320000	32	51,0	2"	88,1	108,2

REV.2.1

// HOSE MENDER

// H14C5610

Hose Mender

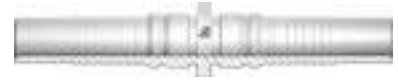

Item Code	Product Code	ID (Dash)	ID (mm)	ID (in)
1219636	H14C5610-101000	10	16,0	5/8"
1235392	H14C5610-202000	20	32,0	1 1/4"
1235393	H14C5610-242400	24	38,0	1 1/2"
1235394	H14C5610-323200	32	51,0	2"

// BSP INSERTS

// H1410510

**BSP Male 60° Flare
AGR**

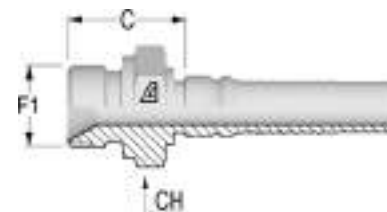

Item Code	Product Code	ID (Dash)	ID (mm)	ID (in)	F1 Dash	F1	C (mm)	CH (mm)
1200218	H1410510-121200	12	19,0	3/4"	12	3/4-14	34,0	32,0
1200239	H1410510-161600	16	25,0	1"	16	1-11	40,0	41,0
1201219	H1410510-202000	20	32,0	1 1/4"	20	1 1/4-11	45,2	50,0
1200280	H1410510-242400	24	38,0	1 1/2"	24	1 1/2-11	48,5	55,0
1201080	H1410510-323200	32	51,0	2"	32	2-11	55,5	70,0

// H1410710

**BSPT Male
AGR K**

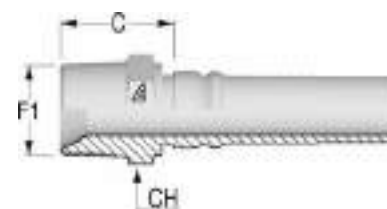

Item Code	Product Code	ID (Dash)	ID (mm)	ID (in)	F1 Dash	F1	C (mm)	CH (mm)
1200215	H1410710-121200	12	19,0	3/4"	12	3/4-14	32,0	27,0
1200237	H1410710-161600	16	25,0	1"	16	1-11	42,0	36,0
1200261	H1410710-202000	20	32,0	1 1/4"	20	1 1/4-11	46,2	46,0
1200278	H1410710-242400	24	38,0	1 1/2"	24	1 1/2-11	48,0	50,0

// H1420812

**BSP Female 60° Cone with O-Ring
DKOR**

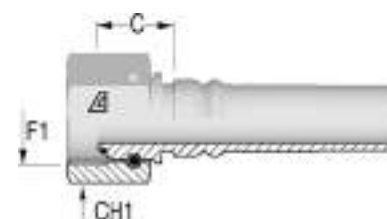

Item Code	Product Code	Nut Type	ID (Dash)	ID (mm)	ID (in)	F1 Dash	F1	C (mm)	CH1 (mm)
1214247	H1420811-080800	Crimped	8	13,0	1/2"	8	1/2-14	19,5	27,0
1202424	H1420812-121200	Thrust wire nut	12	19,0	3/4"	12	3/4-14	22,5	32,0
1202440	H1420812-161600	Thrust wire nut	16	25,0	1"	16	1-11	25,5	38,0
1201132	H1420812-202000	Thrust wire nut	20	32,0	1 1/4"	20	1 1/4-11	30,2	50,0
1201134	H1420812-242400	Thrust wire nut	24	38,0	1 1/2"	24	1 1/2-11	33,5	55,0
1201136	H1420812-323200	Thrust wire nut	32	51,0	2"	32	2-11	35,0	70,0

Image: insert with Thrust Wire Nut.

REV.2.1

// H1420842

45° BSPP Female 60° Cone with O-Ring

DKOR 45

Solid one piece

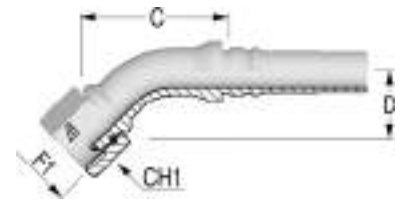

Item Code	Product Code	Nut Type	ID (Dash)	ID (mm)	ID (in)	F1 Dash	F1	C (mm)	D Drop (mm)	CH1 (mm)
1202447	H1420842-121200	Thrust wire nut	12	19,0	3/4"	12	3/4-14	72,0	30,0	32,0
1202446	H1420842-161600	Thrust wire nut	16	25,0	1"	16	1-11	81,0	34,0	38,0
1202444	H1420842-202000	Thrust wire nut	20	32,0	1 1/4"	20	1 1/4-11	97,0	40,0	50,0
1202442	H1420842-242400	Thrust wire nut	24	38,0	1 1/2"	24	1 1/2-11	113,0	46,0	55,0
1201535	H1420842-323200	Thrust wire nut	32	51,0	2"	32	2-11	151,0	60,0	70,0

// H1420892

90° BSPP Female 60° Cone with O-Ring

DKOR 90

Solid one piece



Item Code	Product Code	Nut Type	ID (Dash)	ID (mm)	ID (in)	F1 Dash	F1	C (mm)	D Drop (mm)	CH1 (mm)
1200217	H1420892-121200	Thrust wire nut	12	19,0	3/4"	12	3/4-14	58,0	61,0	32,0
1202445	H1420892-161600	Thrust wire nut	16	25,0	1"	16	1-11	75,0	71,0	38,0
1202443	H1420892-202000	Thrust wire nut	20	32,0	1 1/4"	20	1 1/4-11	79,0	83,0	50,0
1202441	H1420892-242400	Thrust wire nut	24	38,0	1 1/2"	24	1 1/2-11	93,0	96,0	55,0
1200288	H1420892-323200	Thrust wire nut	32	51,0	2"	32	2-11	134,0	130,0	70,0

// DIN METRIC INSERTS

// H1411210

Metric Male 24° Seat
DIN 3853 - Heavy Series
CES

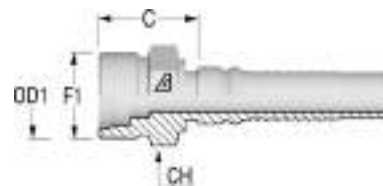

Item Code	Product Code	ID (Dash)	ID (mm)	ID (in)	F1	OD1	C (mm)	CH (mm)
1216929	H1411210-082400	8	13,0	1/2"	M24X1.5	16	27,0	24,0
1201077	H1411210-103000	10	16,0	5/8"	M30X2	20	31,0	32,0
1200212	H1411210-123600	12	19,0	3/4"	M36X2	25	35,0	36,0
1200236	H1411210-164200	16	25,0	1"	M42X2	30	40,0	46,0
1200260	H1411210-205200	20	32,0	1 1/4"	M52X2	38	45,2	55,0

// H1421613

Metric Female 24° Cone with O-Ring
DIN 3865 - Heavy Series
DKOS

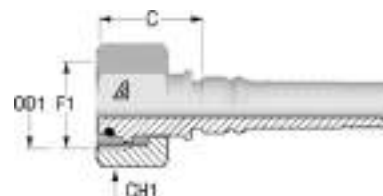

Item Code	Product Code	Nut Type	ID (Dash)	ID (mm)	ID (in)	F1	OD1	C (mm)	CH1 (mm)
1201857	H1421613-082400	Slip on nut	8	13,0	1/2"	M24X1.5	16	29,6	30,0
1201118	H1421613-103000	Slip on nut	10	16,0	5/8"	M30X2	20	34,4	36,0
1202584	H1421612-123000	Thrust wire nut	12	19,0	3/4"	M30X2	20	37,5	36,0
1201092	H1421613-123600	Slip on nut	12	19,0	3/4"	M36X2	25	37,6	46,0
1202887	H1421612-163600	Thrust wire nut	16	25,0	1"	M36X2	25	38,8	46,0
1201125	H1421613-164200	Slip on nut	16	25,0	1"	M42X2	30	40,7	50,0
1216935	H1421612-204200	Thrust wire nut	20	32,0	1 1/4"	M42X2	30	43,6	50,0
1201129	H1421613-205200	Slip on nut	20	32,0	1 1/4"	M52X2	38	45,3	60,0
1216936	H1421612-245200	Thrust wire nut	24	38,0	1 1/2"	M52X2	38	50,8	60,0

Image: insert with Slip on Nut.

REV.2.1

// H1421643

45° Metric Female 24° Cone with O-Ring

DIN 3865 - Heavy Series

DKOS

Solid one piece

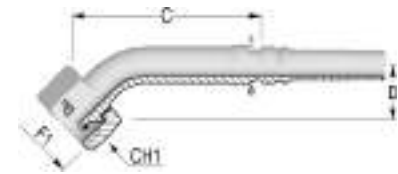

Item Code	Product Code	Nut Type	ID (Dash)	ID (mm)	ID (in)	F1	OD1	C (mm)	D Drop (mm)	CH1 (mm)
1216942	H1421643-082400	Slip on nut	8	13,0	1/2"	M24X1.5	16	83,0	29,0	30,0
1202073	H1421643-103000	Slip on nut	10	16,0	5/8"	M30X2	20	59,0	31,5	36,0
1202583	H1421642-123000	Thrust wire nut	12	19,0	3/4"	M30X2	20	74,0	33,0	36,0
1202079	H1421643-123600	Slip on nut	12	19,0	3/4"	M36X2	25	78,1	36,0	46,0
1216940	H1421642-163600	Thrust wire nut	16	25,0	1"	M36X2	25	86,5	37,5	46,0
1201724	H1421643-164200	Slip on nut	16	25,0	1"	M42X2	30	96,8	38,0	50,0
1202003	H1421643-205200	Slip on nut	20	32,0	1 1/4"	M52X2	38	112,7	48,0	60,0
1216941	H1421642-245200	Thrust wire nut	24	38,0	1 1/2"	M52X2	38	111,0	44,0	60,0

Image: insert with Slip on Nut.

// H1421693

90° Metric Female 24° Cone with O-Ring

DIN 3865 - Heavy Series

DKOS 90

Solid one piece

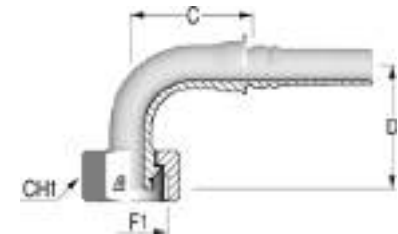

Item Code	Product Code	Nut Type	ID (Dash)	ID (mm)	ID (in)	F1	OD1	C (mm)	D Drop (mm)	CH1 (mm)
1203125	H1421693-082400	Slip on nut	8	13,0	1/2"	M24X1.5	16	52,0	50,0	30,0
1202072	H1421693-103000	Slip on nut	10	16,0	5/8"	M30X2	20	48,0	55,0	36,0
1202582	H1421692-123000	Thrust wire nut	12	19,0	3/4"	M30X2	20	61,0	67,5	36,0
1201723	H1421693-123600	Slip on nut	12	19,0	3/4"	M36X2	25	61,7	65,0	46,0
1203126	H1421692-163600	Thrust wire nut	16	25,0	1"	M36X2	25	76,5	82,0	46,0
1201740	H1421693-164200	Slip on nut	16	25,0	1"	M42X2	30	86,4	79,0	50,0
1201059	H1421693-205200	Slip on nut	20	32,0	1 1/4"	M52X2	38	90,9	101,0	60,0
1216945	H1421692-245200	Thrust wire nut	24	38,0	1 1/2"	M52X2	38	100,5	102,0	60,0

Image: insert with Slip on Nut.

// JIC 37° INSERTS

// H1412510

JIC Male 37° Cone
AGJ

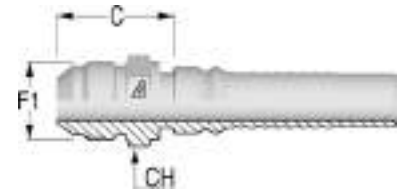

Item Code	Product Code	ID (Dash)	ID (mm)	ID (in)	F1 Dash	F1	C (mm)	CH (mm)
1200216	H1412510-121200	12	19,0	3/4"	12	1 1/16-12	37,0	32,0
1201094	H1412510-121600	12	19,0	3/4"	16	1 5/16-12	40,0	36,0
1200238	H1412510-161600	16	25,0	1"	16	1 5/16-12	41,0	36,0
1201787	H1412510-162000	16	25,0	1"	20	1 5/8-12	44,5	46,0
1200262	H1412510-202000	20	32,0	1 1/4"	20	1 5/8-12	45,7	46,0
1216931	H1412510-202400	20	32,0	1 1/4"	24	1 7/8-12	49,7	50,0
1200279	H1412510-242400	24	38,0	1 1/2"	24	1 7/8-12	50,0	50,0
1201798	H1412510-323200	32	51,0	2"	32	2 1/2-12	61,0	65,0

// H1422512

JIC Female 37° Seat
DKJ

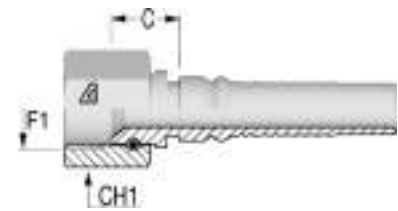

Item Code	Product Code	Nut Type	ID (Dash)	ID (mm)	ID (in)	F1 Dash	F1	C (mm)	CH1 (mm)
1201265	H1422512-101200	Thrust wire nut	10	16,0	5/8"	12	1 1/16-12	18,7	32,0
1201121	H1422512-121200	Thrust wire nut	12	19,0	3/4"	12	1 1/16-12	18,7	32,0
1201122	H1422512-121600	Thrust wire nut	12	19,0	3/4"	16	1 5/16-12	21,5	38,0
1201126	H1422512-161600	Thrust wire nut	16	25,0	1"	16	1 5/16-12	22,5	38,0
1201127	H1422512-162000	Thrust wire nut	16	25,0	1"	20	1 5/8-12	24,5	50,0
1201131	H1422512-202000	Thrust wire nut	20	32,0	1 1/4"	20	1 5/8-12	25,7	50,0
1216973	H1422512-202400	Thrust wire nut	20	32,0	1 1/4"	24	1 7/8-12	28,2	55,0
1201133	H1422512-242400	Thrust wire nut	24	38,0	1 1/2"	24	1 7/8-12	29,0	55,0
1201135	H1422512-323200	Thrust wire nut	32	51,0	2"	32	2 1/2-12	34,0	70,0

REV.2.1

// H1422542
45° JIC Female 37° Seat
DKJ 45
Solid one piece

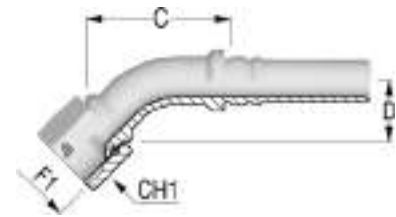

Item Code	Product Code	Nut Type	ID (Dash)	ID (mm)	ID (in)	F1 Dash	F1	C (mm)	D Drop (mm)	CH1 (mm)
1201485	H1422542-121200	Thrust wire nut	12	19,0	3/4"	12	1 1/16-12	66,0	27,5	32,0
1202098	H1422542-121600	Thrust wire nut	12	19,0	3/4"	16	1 5/16-12	72,0	30,0	38,0
1201486	H1422542-161600	Thrust wire nut	16	25,0	1"	16	1 5/16-12	79,5	31,0	38,0
1201487	H1422542-202000	Thrust wire nut	20	32,0	1 1/4"	20	1 5/8-12	93,0	37,0	50,0
1201765	H1422542-242400	Thrust wire nut	24	38,0	1 1/2"	24	1 7/8-12	121,0	38,0	55,0

// H1422592
90° JIC Female 37° Seat
DKJ 90
Solid one piece



Item Code	Product Code	Nut Type	ID (Dash)	ID (mm)	ID (in)	F1 Dash	F1	C (mm)	D Drop (mm)	CH1 (mm)
1201488	H1422592-121200	Thrust wire nut	12	19,0	3/4"	12	1 1/16-12	45,0	57,0	32,0
1202103	H1422592-121600	Thrust wire nut	12	19,0	3/4"	16	1 5/16-12	58,0	60,5	38,0
1201489	H1422592-161600	Thrust wire nut	16	25,0	1"	16	1 5/16-12	71,0	67,0	38,0
1201490	H1422592-202000	Thrust wire nut	20	32,0	1 1/4"	20	1 5/8-12	79,2	78,0	50,0
1201491	H1422592-242400	Thrust wire nut	24	38,0	1 1/2"	24	1 7/8-12	94,5	92,0	55,0
1201796	H1422592-323200	Thrust wire nut	32	51,0	2"	32	2 1/2-12	132,0	120,5	70,0

// NPTF INSERTS

// H1412810

NPTF Male 60° Seat
AGN

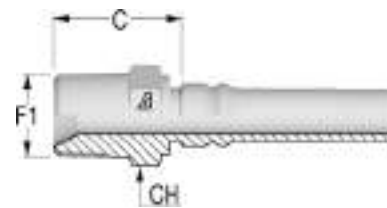

Item Code	Product Code	ID (Dash)	ID (mm)	ID (in)	F1 Dash	F1	C (mm)	CH (mm)
1201609	H1412810-060600	6	10,0	3/8"	6	3/8-18	26,5	19,0
1203127	H1412810-080800	8	13,0	1/2"	8	1/2-14	30,0	22,0
1200193	H1412810-121200	12	19,0	3/4"	12	3/4-14	32,0	27,0
1200219	H1412810-161600	16	25,0	1"	16	1-11 1/2	42,0	36,0
1200240	H1412810-202000	20	32,0	1 1/4"	20	1 1/4-11 1/2	46,2	46,0
1200263	H1412810-242400	24	38,0	1 1/2"	24	1 1/2-11 1/2	48,0	50,0
1200281	H1412810-323200	32	51,0	2"	32	2-11 1/2	53,2	65,0

REV.2.1

// ORFS INSERTS

// H1412410

ORFS Male

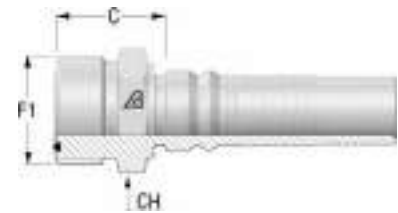

Item Code	Product Code	ID (Dash)	ID (mm)	ID (in)	F1 Dash	F1	C (mm)	CH (mm)
1214664	H1412410-121200	12	19,0	3/4"	12	1 3/16-12	30,2	30,0
1231483	H1412410-161600	16	25,0	1"	16	1 7/16-12	35,8	38,0
1226310	H1412410-202000	20	32,0	1 1/4"	20	1 11/16-12	39,1	46,0
1226312	H1412410-242400	24	38,0	1 1/2"	24	2-12	41,0	55,0

// H1422411

ORFS Female with Stem Hexagon

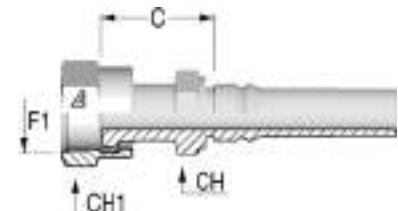

Item Code	Product Code	Nut Type	ID (Dash)	ID (mm)	ID (in)	F1 Dash	F1	C (mm)	CH (mm)	CH1 (mm)
1202864	H1422411-101200	Crimped	10	16,0	5/8"	12	1 3/16-12	40,0	30,0	36,0
1202099	H1422411-121200	Crimped	12	19,0	3/4"	12	1 3/16-12	40,0	30,0	36,0
1202106	H1422411-121600	Crimped	12	19,0	3/4"	16	1 7/16-12	43,0	36,0	41,0
1216952	H1422411-161200	Crimped	16	25,0	1"	12	1 3/16-12	42,0	32,0	36,0
1202071	H1422411-161600	Crimped	16	25,0	1"	16	1 7/16-12	47,0	36,0	41,0
1202107	H1422411-162000	Crimped	16	25,0	1"	20	1 11/16-12	49,0	46,0	50,0
1216955	H1422411-201600	Crimped	20	32,0	1 1/4"	16	1 7/16-12	47,2	41,0	41,0
1201807	H1422411-202000	Crimped	20	32,0	1 1/4"	20	1 11/16-12	47,2	46,0	50,0
1216956	H1422411-242400	Crimped	24	38,0	1 1/2"	24	2-12	52,0	50,0	60,0

// H1422441

45° ORFS Female

DK ORFS 45

Solid one piece

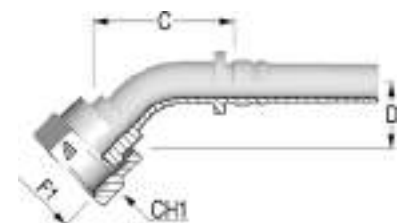

Item Code	Product Code	Nut Type	ID (Dash)	ID (mm)	ID (in)	F1 Dash	F1	C (mm)	D Drop (mm)	CH1 (mm)
1202108	H1422441-121200	Crimped	12	19,0	3/4"	12	1 3/16-12	77,7	26,0	36,0
1202109	H1422441-121600	Crimped	12	19,0	3/4"	16	1 7/16-12	68,4	28,0	41,0
1202110	H1422441-161600	Crimped	16	25,0	1"	16	1 7/16-12	114,0	28,0	41,0
1202111	H1422441-162000	Crimped	16	25,0	1"	20	1 11/16-12	83,4	28,0	50,0
1202112	H1422441-202000	Crimped	20	32,0	1 1/4"	20	1 11/16-12	100,7	33,0	50,0

// H1422491
90° ORFS Female
DK ORFS 90
Solid one piece

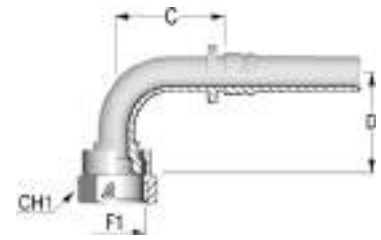

Item Code	Product Code	Nut Type	ID (Dash)	ID (mm)	ID (in)	F1 Dash	F1	C (mm)	D Drop (mm)	CH1 (mm)
1203123	H1422491-101200	Crimped	10	16,0	5/8"	12	1 3/16-12	48,1	58,0	36,0
1202117	H1422491-121200	Crimped	12	19,0	3/4"	12	1 3/16-12	64,2	58,0	36,0
1202116	H1422491-121600	Crimped	12	19,0	3/4"	16	1 7/16-12	66,2	58,0	41,0
1202115	H1422491-161600	Crimped	16	25,0	1"	16	1 7/16-12	75,2	66,0	41,0
1202114	H1422491-162000	Crimped	16	25,0	1"	20	1 11/16-12	73,2	66,0	50,0
1202113	H1422491-202000	Crimped	20	32,0	1 1/4"	20	1 11/16-12	91,7	81,0	50,0

// SAE FLANGES

// H1443310

Flange SAE 3000 psi J518 Code 61
SFL

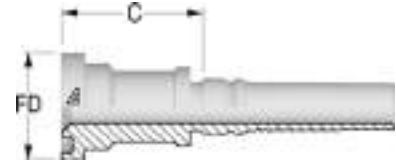

Item Code	Product Code	ID (Dash)	ID (mm)	ID (in)	F1 Dash	F1	C (mm)	FD (mm)	WP (psi)
1200233	H1443310-161600	16	25,0	1"	16	1	49,0	44,5	5000
1200234	H1443310-162000	16	25,0	1"	20	1 1/4	51,5	50,8	4000
1200257	H1443310-202000	20	32,0	1 1/4"	20	1 1/4	52,7	50,8	4000
1200256	H1443310-202400	20	32,0	1 1/4"	24	1 1/2	55,7	60,3	3000
1200276	H1443310-242400	24	38,0	1 1/2"	24	1 1/2	56,0	60,3	3000
1200277	H1443310-243200	24	38,0	1 1/2"	32	2	67,5	71,4	3000
1200287	H1443310-323200	32	51,0	2"	32	2	69,0	71,4	3000

// H1443340

45° Flange SAE 3000 psi J518 Code 61
SFL 45
Solid one piece

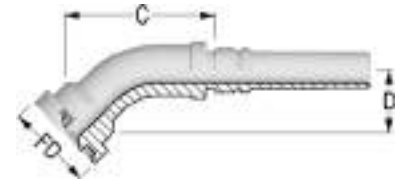

Item Code	Product Code	ID (Dash)	ID (mm)	ID (in)	F1 Dash	F1	FD (mm)	C (mm)	D Drop (mm)	WP (psi)
1200230	H1443340-162000	16	25,0	1"	20	1 1/4	50,8	95,6	30,0	4000
1200253	H1443340-202000	20	32,0	1 1/4"	20	1 1/4	50,8	100,9	32,5	4000
1200252	H1443340-202400	20	32,0	1 1/4"	24	1 1/2	60,3	92,8	40,0	3000
1200272	H1443340-242400	24	38,0	1 1/2"	24	1 1/2	60,3	103,7	43,0	3000
1200273	H1443340-243200	24	38,0	1 1/2"	32	2	71,4	132,7	56,5	3000
1200285	H1443340-323200	32	51,0	2"	32	2	71,4	138,1	54,0	3000

// H1443390

90° Flange SAE 3000 psi J518 Code 61
SFL 90
Solid one piece

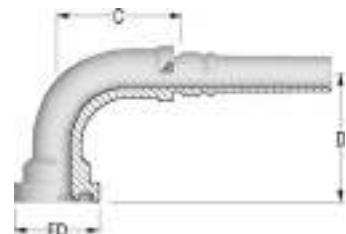

Item Code	Product Code	ID (Dash)	ID (mm)	ID (in)	F1 Dash	F1	FD (mm)	C (mm)	D Drop (mm)	WP (psi)
1200231	H1443390-161600	16	25,0	1"	16	1	44,5	72,2	64,0	5000
1200232	H1443390-162000	16	25,0	1"	20	1 1/4	50,8	70,2	69,0	4000
1200255	H1443390-202000	20	32,0	1 1/4"	20	1 1/4	50,8	86,2	81,0	4000
1200254	H1443390-202400	20	32,0	1 1/4"	24	1 1/2	60,3	81,2	85,0	3000
1200274	H1443390-242400	24	38,0	1 1/2"	24	1 1/2	60,3	95,5	93,0	3000
1200275	H1443390-243200	24	38,0	1 1/2"	32	2	71,4	130,3	97,0	3000
1200286	H1443390-323200	32	51,0	2"	32	2	71,4	134,4	130,0	3000

// H1443610

Flange SAE 6000 psi J518 Code 62
SFS

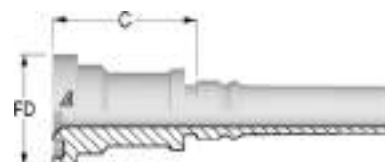

Item Code	Product Code	ID (Dash)	ID (mm)	ID (in)	F1 Dash	F1	C (mm)	FD (mm)	WP (psi)
1200199	H1443610-121200	12	19,0	3/4"	12	3/4	50,0	41,3	6000
1200198	H1443610-121600	12	19,0	3/4"	16	1	53,0	47,6	6000
1201218	H1443610-161200	16	25,0	1"	12	3/4	51,0	41,3	6000
1200224	H1443610-161600	16	25,0	1"	16	1	54,0	47,6	6000
1200225	H1443610-162000	16	25,0	1"	20	1 1/4	61,0	54,0	6000
1201556	H1443610-201600	20	32,0	1 1/4"	16	1	80,2	47,6	6000
1200246	H1443610-202000	20	32,0	1 1/4"	20	1 1/4	62,2	54,0	6000
1200245	H1443610-202400	20	32,0	1 1/4"	24	1 1/2	68,2	63,5	6000
1200270	H1443610-242000	24	38,0	1 1/2"	20	1 1/4	62,5	54,0	6000
1200268	H1443610-242400	24	38,0	1 1/2"	24	1 1/2	68,5	63,5	6000
1200271	H1443610-243200	24	38,0	1 1/2"	32	2	80,5	79,4	6000
1200284	H1443610-323200	32	51,0	2"	32	2	87,0	79,4	6000

// H1443640

45° Flange SAE 6000 psi J518 Code 62
SFS 45
Solid one piece

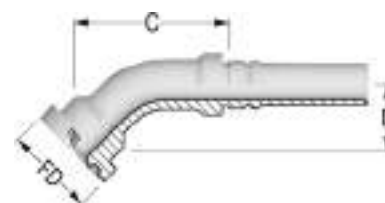

Item Code	Product Code	ID (Dash)	ID (mm)	ID (in)	F1 Dash	F1	FD (mm)	C (mm)	D Drop (mm)	WP (psi)
1200195	H1443640-121200	12	19,0	3/4"	12	3/4	41,3	72,1	30,0	6000
1200194	H1443640-121600	12	19,0	3/4"	16	1	47,6	76,8	33,0	6000
1202890	H1443640-161200	16	25,0	1"	12	3/4	41,3	80,3	29,5	6000
1200220	H1443640-161600	16	25,0	1"	16	1	47,6	94,8	35,0	6000
1200221	H1443640-162000	16	25,0	1"	20	1 1/4	54,0	105,3	44,0	6000
1201557	H1443640-201600	20	32,0	1 1/4"	16	1	47,6	104,7	34,5	6000
1200242	H1443640-202000	20	32,0	1 1/4"	20	1 1/4	54,0	102,0	39,5	6000
1200241	H1443640-202400	20	32,0	1 1/4"	24	1 1/2	63,5	111,7	48,0	6000
1200264	H1443640-242400	24	38,0	1 1/2"	24	1 1/2	63,5	136,3	48,0	6000
1200265	H1443640-243200	24	38,0	1 1/2"	32	2	79,4	129,1	55,0	6000
1200282	H1443640-323200	32	51,0	2"	32	2	79,4	160,6	63,0	6000

REV.2.1

// H1443690

90° Flange SAE 6000 psi J518 Code 62

SFS 90

Solid one piece

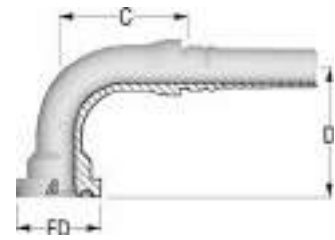

Item Code	Product Code	ID (Dash)	ID (mm)	ID (in)	F1 Dash	F1	FD (mm)	C (mm)	D Drop (mm)	WP (psi)
1200197	H1443690-121200	12	19,0	3/4"	12	3/4	41,3	61,2	64,0	6000
1200196	H1443690-121600	12	19,0	3/4"	16	1	47,6	61,2	66,0	6000
1202811	H1443690-161200	16	25,0	1"	12	3/4	41,3	70,2	61,0	6000
1200222	H1443690-161600	16	25,0	1"	16	1	47,6	70,4	74,0	6000
1200223	H1443690-162000	16	25,0	1"	20	1 1/4	54,0	77,2	80,0	6000
1200244	H1443690-202000	20	32,0	1 1/4"	20	1 1/4	54,0	88,2	91,0	6000
1200243	H1443690-202400	20	32,0	1 1/4"	24	1 1/2	63,5	92,9	103,5	6000
1200266	H1443690-242400	24	38,0	1 1/2"	24	1 1/2	63,5	106,3	109,0	6000
1200267	H1443690-243200	24	38,0	1 1/2"	32	2	79,4	106,5	121,5	6000
1200283	H1443690-323200	32	51,0	2"	32	2	79,4	146,0	145,0	6000

// H1T43610

Flange SAE 6000 psi J518 Code 62

SFS

Special version

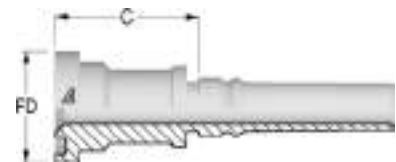

Item Code	Product Code	ID (Dash)	ID (mm)	ID (in)	F1 Dash	F1	C (mm)	FD (mm)	WP (psi)
1223166	H1T43610-322400	32	51,0	2"	24	1 1/2	106,0	63,5	6000
1223388	H1T43610-323200	32	51,0	2"	32	2	104,0	79,4	6000
1235395	H1T43610-404000	40	63,0	2 1/2"	40	2 1/2	124,3	108,0	6000

// H1T43640

45° Flange SAE 6000 psi J518 Code 62

SFS 45

Solid one piece

Special version

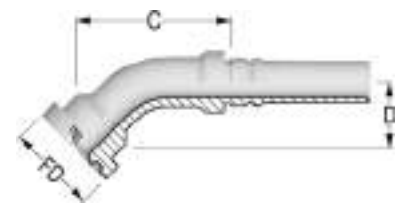

Item Code	Product Code	ID (Dash)	ID (mm)	ID (in)	F1 Dash	F1	FD (mm)	C (mm)	D Drop (mm)	WP (psi)
1223389	H1T43640-323200	32	51,0	2"	32	2	79,4	141,0	63,0	6000

// H1T43690

90° Flange SAE 6000 psi J518 Code 62

SFS 90

Solid one piece

Special version

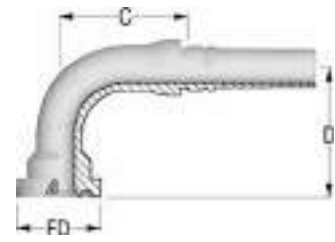

Item Code	Product Code	ID (Dash)	ID (mm)	ID (in)	F1 Dash	F1	FD (mm)	C (mm)	D Drop (mm)	WP (psi)
1223168	H1T43690-322400	32	51,0	2"	24	1 1/2	63,5	134,0	112,0	6000
1228051	H1T43690-323200	32	51,0	2"	32	2	79,4	132,0	145,0	6000

// SUPERCAT FLANGES

// H1443910

Flange SUPERCAT

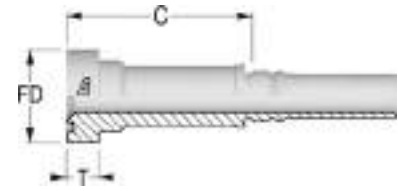

Item Code	Product Code	ID (Dash)	ID (mm)	ID (in)	F1 Dash	F1	FD (mm)	T (mm)	C (mm)
1202219	H1443910-121200	12	19,0	3/4"	12	3/4	41,3	14,3	82,0
1202388	H1443910-121600	12	19,0	3/4"	16	1	47,6	14,3	82,0
1202389	H1443910-161600	16	25,0	1"	16	1	47,6	14,3	90,0
1202390	H1443910-162000	16	25,0	1"	20	1 1/4	54,0	14,3	90,0
1202391	H1443910-202000	20	32,0	1 1/4"	20	1 1/4	54,0	14,3	86,2
1202392	H1443910-202400	20	32,0	1 1/4"	24	1 1/2	63,5	14,3	83,2

// H1443940

45° Flange SUPERCAT

Solid one piece

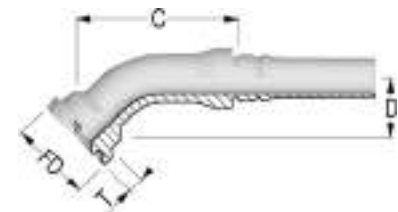

Item Code	Product Code	ID (Dash)	ID (mm)	ID (in)	F1 Dash	F1	FD (mm)	T (mm)	C (mm)	D Drop (mm)
1202398	H1443940-121200	12	19,0	3/4"	12	3/4	41,3	14,3	82,9	34,0
1202397	H1443940-121600	12	19,0	3/4"	16	1	47,6	14,3	87,4	34,0
1202396	H1443940-161600	16	25,0	1"	16	1	47,6	14,3	93,9	40,0
1202395	H1443940-162000	16	25,0	1"	20	1 1/4	54,0	14,3	95,4	40,0
1202394	H1443940-202000	20	32,0	1 1/4"	20	1 1/4	54,0	14,3	103,6	43,0
1202393	H1443940-202400	20	32,0	1 1/4"	24	1 1/2	63,5	14,3	110,1	49,5

// H1443990

90° Flange SUPERCAT

Solid one piece

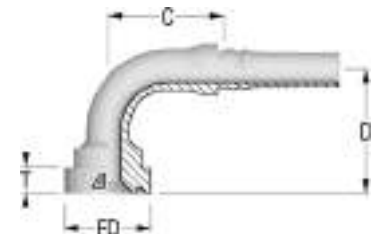

Item Code	Product Code	ID (Dash)	ID (mm)	ID (in)	F1 Dash	F1	FD (mm)	T (mm)	C (mm)	D Drop (mm)
1202399	H1443990-121200	12	19,0	3/4"	12	3/4	41,3	14,3	63,7	67,0
1202400	H1443990-121600	12	19,0	3/4"	16	1	47,6	14,3	65,2	70,0
1202401	H1443990-161600	16	25,0	1"	16	1	47,6	14,3	80,4	79,0
1202402	H1443990-162000	16	25,0	1"	20	1 1/4	54,0	14,3	75,4	82,5
1202403	H1443990-202000	20	32,0	1 1/4"	20	1 1/4	54,0	14,3	89,2	93,0
1202404	H1443990-202400	20	32,0	1 1/4"	24	1 1/2	63,5	14,3	91,4	101,0

// HAMMER UNION

// H1T13F13

Male Hammer Union Fig. 1502 Integral Fitting with Lug Nut
Special version



Item Code	Product Code	ID (Dash)	ID (mm)	ID (in)	C (mm)	L (mm)
1235624	H1T13F13-323200	32	51,0	2"	60,8	162,2

// H1T23F10

Female Hammer Union Fig. 1502 Integral Fitting with Rubber Ring
Special version

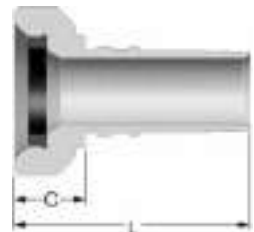

Item Code	Product Code	ID (Dash)	ID (mm)	ID (in)	C (mm)	L (mm)
1235623	H1T23F10-323200	32	51,0	2"	57,3	158,7



// ACCESSORIES

// SAFE-WRAP.....	349	// LOWER MOUNT.....	366
// WIPCHECK.....	350	// BACK MOUNT.....	367
// PLASTIC.....	353	// ACCESSORY.....	368
// TEXTILE.....	355	// THREADED FLANGES.....	369
// HIGH TEMPERATURE & FIRE PROTECTION.....	356	// THREADED COUNTER FLANGES.....	370
// PRESSURE WASH.....	358	// BUTT WELD CONTROL FLANGE.....	371
// NON-RETURN VALVES.....	359	// O-RING.....	372
// BALL VALVES 2-WAY.....	363	// PROFILED GASKET.....	375
// BALL VALVES 3-WAY.....	364	// BONDED SEAL.....	376
// SWIVEL CONNECTOR.....	365		

// SAFE-WRAP

// RTY1G0P_VC

Black Textile Sleeve with Velcro®**Application:** hose protection and hose bundling.**Benefits:** very easy and fast to install.

- excellent tensile strength
- abrasion resistant
- 100% water repellent

Material: polyamide with PU coating and Velcro®-brand fasteners**Temperature:** -20 °C +120 °C (-4 °F +248 °F)

Item Code	ID (mm)	L (m)
1905729	40	25,0
1902060	60	0,8
1902539	60	1,0
1902540	60	1,2
1901814	60	10,0
1901813	80	10,0
1901820	100	10,0
1901884	120	10,0
1901885	150	50,0
1903103	170	0,9
1901886	175	50,0
1903102	195	0,9

// WIPCHECK

// R1YCCD1

Retention System for DIN 24° Adapter Complete Whip Chain

Notes: Not suitable for high-pressure air and compressed gas hoses



Item Code	Product Code	Max OD (mm)	Cable L (mm)	WP (bar)	Notes
1902249	R1YCCD1-1450300	15	300	450	SMALL PLATE
1902252	R1YCCD1-1700200	17	300	445	SMALL PLATE
1902510	R1YCCD1-1850200	19	300	420	SMALL PLATE
1902511	R1YCCD1-2050200	21	300	420	SMALL PLATE
1902257	R1YCCD1-2250300	23	300	420	SMALL PLATE
1902259	R1YCCD1-2450200	25	300	420	SMALL PLATE
1902262	R1YCCD1-2650200	27	300	420	SMALL PLATE
1902266	R1YCCD1-3050200	31	300	420	SMALL PLATE
1902269	R1YCCD1-3400450	34	450	420	LARGE PLATE
1902271	R1YCCD1-3650450	37	450	420	LARGE PLATE
1902276	R1YCCD1-4250450	43	450	420	LARGE PLATE
1902280	R1YCCD1-4550450	46	450	420	LARGE PLATE
1902512	R1YCCD1-4900450	49	450	420	LARGE PLATE
1902284	R1YCCD1-5250450	53	450	380	LARGE PLATE
1902289	R1YCCD1-6000450	60	450	350	LARGE PLATE

// R1YCCF1

Retention System for SAE 3K-6K Flanges Complete Whip Chain

Notes: Not suitable for high-pressure air and compressed gas hoses



Item Code	Product Code	Max OD (mm)	Cable L (mm)	WP (bar)	Notes
1902298	R1YCCF1-0850300	9	300	415	SMALL PLATE
1902513	R1YCCF1-1050300	11	300	420	SMALL PLATE
1902243	R1YCCF1-1050450	11	450	420	LARGE PLATE
1902246	R1YCCF1-1250450	13	450	420	LARGE PLATE
1901675	R1YCCF1-1450450	15	450	420	LARGE PLATE
1901670	R1YCCF1-1650450	17	450	420	LARGE PLATE
1901083	R1YCCF1-2050450	21	450	350	LARGE PLATE

REV.2.1

// R1YCCJ1

**Retention System for JIC 37° Adapter
Complete Whip Chain****Notes:** Not suitable for high-pressure air and compressed gas hoses

Item Code	Product Code	Max OD (mm)	Cable L (mm)	WP (bar)	Notes
1904781	R1YCCJ1-115300	12	300	450	SMALL PLATE
1904782	R1YCCJ1-132300	13	300	450	SMALL PLATE
1904783	R1YCCJ1-148300	15	300	450	SMALL PLATE
1904784	R1YCCJ1-195300	20	300	420	SMALL PLATE
1904785	R1YCCJ1-228300	23	300	420	SMALL PLATE
1904786	R1YCCJ1-275300	28	300	420	SMALL PLATE
1904787	R1YCCJ1-307300	31	300	420	SMALL PLATE
1904788	R1YCCJ1-340450	34	450	420	SMALL PLATE
1904789	R1YCCJ1-340450_L	34	450	420	LARGE PLATE
1904791	R1YCCJ1-415450	42	450	420	SMALL PLATE
1904790	R1YCCJ1-415450_L	42	450	420	LARGE PLATE
1904793	R1YCCJ1-480450	48	450	420	SMALL PLATE
1904792	R1YCCJ1-480450_L	48	450	420	LARGE PLATE
1904794	R1YCCJ1-640450	64	450	350	SMALL PLATE

// R1YCCH1

**Retention System
Bolt Clamp****Notes:** Not suitable for high-pressure air and compressed gas hoses

Item Code	Product Code	Product Code	Hose OD Range (mm)	Notes
1902244	R1YCCH1-0110115	R1YCCH1-0110115	11 - 11.5	M6 BOLT
1902245	R1YCCH1-0120125	R1YCCH1-0120125	12 - 12.5	M6 BOLT
1902247	R1YCCH1-0130135	R1YCCH1-0130135	13 - 13.5	M6 BOLT
1902248	R1YCCH1-0140150	R1YCCH1-0140150	14 - 15	M6 BOLT
1902250	R1YCCH1-0160170	R1YCCH1-0160170	16 - 17	M6 BOLT
1902251	R1YCCH1-0170180	R1YCCH1-0170180	17 - 18	M6 BOLT
1902253	R1YCCH1-0180190	R1YCCH1-0180190	18 - 19	M6 BOLT
1902254	R1YCCH1-0200210	R1YCCH1-0200210	20 - 21	M6 BOLT
1902255	R1YCCH1-0210220	R1YCCH1-0210220	21 - 22	M6 BOLT
1902256	R1YCCH1-0220230	R1YCCH1-0220230	22 - 23	M6 BOLT
1902258	R1YCCH1-0240250	R1YCCH1-0240250	24 - 25	M6 BOLT
1902260	R1YCCH1-0250260	R1YCCH1-0250260	25 - 26	M6 BOLT
1902261	R1YCCH1-0260270	R1YCCH1-0260270	26 - 27	M6 BOLT
1902263	R1YCCH1-0270280	R1YCCH1-0270280	27 - 28	M6 BOLT
1902264	R1YCCH1-0280290	R1YCCH1-0280290	28 - 29	M6 BOLT
1902265	R1YCCH1-0300310	R1YCCH1-0300310	30 - 31	M6 BOLT
1902267	R1YCCH1-0320330	R1YCCH1-0320330	32 - 33	M6 BOLT
1902268	R1YCCH1-0340350	R1YCCH1-0340350	34 - 35	M6 BOLT
1902270	R1YCCH1-0360370	R1YCCH1-0360370	36 - 37	M6 BOLT
1902272	R1YCCH1-0380390	R1YCCH1-0380390	38 - 39	M6 BOLT
1902273	R1YCCH1-0390400	R1YCCH1-0390400	39 - 40	M6 BOLT
1902274	R1YCCH1-0400410	R1YCCH1-0400410	40 - 41	M6 BOLT
1902275	R1YCCH1-0420430	R1YCCH1-0420430	42 - 43	M6 BOLT
1902277	R1YCCH1-0430440	R1YCCH1-0430440	43 - 44	M6 BOLT
1902278	R1YCCH1-0440450	R1YCCH1-0440450	44 - 45	M6 BOLT

Item Code	Product Code	Product Code	Hose OD Range (mm)	Notes
1902279	R1YCCH1-0450470	R1YCCH1-0450470	45 - 47	M8 BOLT
1902281	R1YCCH1-0480500	R1YCCH1-0480500	48 - 50	M8 BOLT
1901672	R1YCCH1-0480510	R1YCCH1-0480510	48 - 51	M8 BOLT
1902283	R1YCCH1-0510530	R1YCCH1-0510530	51 - 53	M8 BOLT
1902285	R1YCCH1-0530540	R1YCCH1-0530540	53 - 54	M8 BOLT
1902286	R1YCCH1-0540560	R1YCCH1-0540560	54 - 56	M8 BOLT
1901589	R1YCCH1-0560600	R1YCCH1-0560600	56 - 60	M8 BOLT
1902287	R1YCCH1-0570590	R1YCCH1-0570590	57 - 59	M8 BOLT
1902288	R1YCCH1-0600620	R1YCCH1-0600620	60 - 62	M8 BOLT
1902290	R1YCCH1-0630650	R1YCCH1-0630650	63 - 65	M8 BOLT
1902291	R1YCCH1-0660680	R1YCCH1-0660680	66 - 68	M8 BOLT
1902292	R1YCCH1-0690710	R1YCCH1-0690710	69 - 71	M8 BOLT
1902293	R1YCCH1-0720740	R1YCCH1-0720740	72 - 74	M8 BOLT
1902294	R1YCCH1-0750770	R1YCCH1-0750770	75 - 77	M8 BOLT
1902295	R1YCCH1-0780800	R1YCCH1-0780800	78 - 80	M8 BOLT
1902296	R1YCCH1-0810830	R1YCCH1-0810830	81 - 83	M8 BOLT
1902297	R1YCCH1-0840860	R1YCCH1-0840860	84 - 86	M8 BOLT
1902299	R1YCCH1-0870890	R1YCCH1-0870890	87 - 89	M8 BOLT
1902300	R1YCCH1-0900920	R1YCCH1-0900920	90 - 92	M8 BOLT
1902301	R1YCCH1-0930950	R1YCCH1-0930950	93 - 95	M8 BOLT

// R1YCCV1

Retention System

Plate for Various systems

Notes: Not suitable for high-pressure air and compressed gas hoses



Item Code	Product Code	Max OD (mm)	Cable L (mm)	WP (bar)	Notes
1902509	R1YCCV1-1300450	13	450	420	LARGE PLATE

Large plate

REV.2.1

// PLASTIC

// RJS1AGO

Black Plastic Protective Flat Coil Sleeve**Application:** protective sleeve also suitable for group bundling of hose lines.**Temperature:** -20 °C to +84 °C (-4 °F to +180 °F)**Material:** HDPE (high-density polyethylene)

Item Code	Product Code	ID (mm)	OD (mm)	T (mm)	L (m)
1902552	RJS1AGO-0100000	10,5	13,3	1,4	25,0
1902554	RJS1AGO-0130000	13,4	16	1,3	25,0
1902555	RJS1AGO-0160000	16	20	2	25,0
1901061	RJS1AGO-0213000	21	25	2,2	3,0
1901062	RJS1AGO-0216000	21	25	2,2	6,0
1903096	RJS1AGO-0220000	21,6	25	1,7	25,0
1902556	RJS1AGO-0200000	20,6	25	2,2	50,0
1901072	RJS1AGO-0270650	27	32	2,5	0,7
1901073	RJS1AGO-0270900	27	32	2,5	0,9
1901063	RJS1AGO-0271300	27	32	2,5	1,3
1901637	RJS1AGO-0271500	27	32	2,5	1,5
1901070	RJS1AGO-0276000	27	32	2,5	6,0
1901067	RJS1AGO-0270000	27	32	2,5	50,0
1902051	RJS1AGO-0350000	34,6	40	2,7	25,0
1901074	RJS1AGO-0431200	43	50	3,4	1,2
1901079	RJS1AGO-0436000	43	50	3,4	6,0
1901076	RJS1AGO-0430000	43,2	50	3,4	25,0
1902520	RJS1AGO-0550000	55,6	63	3,7	25,0
1901081	RJS1AGO-0661200	66	75	4,4	1,2
1901087	RJS1AGO-0666000	66	75	4,4	6,0
1901142	RJS1AGO-0660000	66,2	75	4,4	20,0
1901089	RJS1AGO-0800000	80,2	90	4,9	20,0
1901043	RJS1AGO-0991000	99	110	5,5	1,0
1901048	RJS1AGO-0996000	99	110	5,5	6,0
1902560	RJS1AGO-0990000	99	110	5,5	15,0
1901052	RJS1AGO-1271200	127	140	6,5	1,2
1902521	RJS1AGO-1270000	127	140	6,5	10,0

// RJS1KGO

Yellow Plastic Protective Flat Coil Sleeve

Application: protective sleeve aslo suitable for group bundling of hose lines.

Temperature: -20 °C to +84 °C (-4 °F to +180 °F)

Material: HDPE (high-density polyethylene)



Item Code	Product Code	ID (mm)	OD (mm)	T (mm)	Pitch (mm)	L (m)
1902551	RJS1KGO-0100000	10	12	1,2	10,5	25,0
1902553	RJS1KGO-0130000	13,4	16	1,3	12	25,0
1901057	RJS1KGO-0160000	16	20	2	20	25,0
1901060	RJS1KGO-0200000	20,6	25	2,2	21	50,0
1901058	RJS1KGO-0211300	21	25	2,2	25	1,3
1901064	RJS1KGO-0271300	27	32	2,5	30	1,3
1902548	RJS1KGO-0271500	27	32	2,5	30	1,5
1901069	RJS1KGO-0273000	27	32	2,5	30	3,0
1901071	RJS1KGO-0276000	27	32	2,5	30	6,0
1902557	RJS1KGO-0270000	27	32	2,5	22	50,0
1903210	RJS1KGO-0350000	34,6	40	2,7	24	25,0
1901075	RJS1KGO-0431200	43	50	3,4	30	1,2
1902549	RJS1KGO-0431550	43	50	3,4	30	1,6
1901080	RJS1KGO-0436000	43	50	3,4	30	6,0
1901077	RJS1KGO-0430000	43,2	50	3,4	30	25,0
1903212	RJS1KGO-0550000	55,6	63	3,7	37	25,0
1904151	RJS1KGO-0660800	66	75	4,4	42	0,8
1901082	RJS1KGO-0661200	66	75	4,4	42	1,2
1902550	RJS1KGO-0661500	66	75	4,4	42	1,5
1901088	RJS1KGO-0666000	66	75	4,4	42	6,0
1901141	RJS1KGO-0660000	66	75	4,4	42	20,0
1902558	RJS1KGO-0800000	80	90	4,9	45	15,0
1901044	RJS1KGO-0991000	99	110	5,5	50	1,0
1901045	RJS1KGO-0991500	99	110	5,5	50	1,5
1901049	RJS1KGO-0996000	99	110	5,5	50	6,0
1902559	RJS1KGO-0990000	99	110	5,5	50	10,0

// RJS1HGO

Red Plastic Protective Flat Coil Sleeve

Application: protective sleeve aslo suitable for group bundling of hose lines.

Temperature: -20 °C to +84 °C (-4 °F to +180 °F)

Material: HDPE (high-density polyethylene)



Item Code	Product Code	ID (mm)	OD (mm)	T (mm)	Pitch (mm)	L (m)
1906648	RJS1HGO-0431200	43	50	3,4	30	25,0

REV.2.1

// TEXTILE

// RTYOG0A

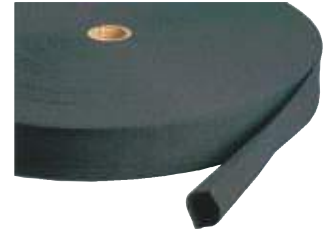
Black Textile Sleeve**Application:** protection from abrasion, weather and high temperature.**Material:** polyethersulfone (PES).**Temperature:** -40 °C +100 °C (-40 °F +212 °F)

Item Code	Product Code	ID (mm)	T (mm)
1900143	RTY0G0A-02000T0	20	0,8
1900147	RTY0G0A-02500T0	25	0,8
1900142	RTY0G0A-03000T0	30	0,8
1902519	RTY0G0A-03500T0	35	0,8
1900145	RTY0G0A-04000T0	40	0,8
1900168	RTY0G0A-04500T0	45	0,8
1900183	RTY0G0A-05000T0	50	0,8
1900167	RTY0G0A-06500T0	65	0,8
1900157	RTY0G0A-07500T0	75	0,8
1900148	RTY0G0A-08500T0	85	0,8
1900151	RTY0G0A-09000T0	90	0,8
1905585	RTY0G0A-10900T0	109	0,8
1903845	RTY0G0A-15000T0	150	0,8

// HIGH TEMPERATURE & FIRE PROTECTION

// RLYGASO_ST

Fire Protection Sleeve Industrial Grade

Application: hose and fittings protection from very high temperature. Specially designed to withstand molten metal splashes.

Material: glass fiber and iron oxide red silicone rubber.

Temperature: - continuous up to +260 °C (500 °F)
- intermittent 15-20 minutes up to 1090 °C (2000 °F)
- Intermittant 15-30 seconds up tp 1650 °C (3000 °F)



Item Code	Product Code	ID (mm)
1906619	RLYGASO-0100000_ST	10
1906620	RLYGASO-0130000_ST	13
1904931	RLYGASO-0160000_ST	16
1905036	RLYGASO-0190000_ST	20
1904984	RLYGASO-0220000_ST	22
1905554	RLYGASO-0250000_ST	25
1904967	RLYGASO-0290000_ST	29
1904932	RLYGASO-0320000_ST	32
1904968	RLYGASO-0380000_ST	38
1904933	RLYGASO-0410000_ST	41
1905185	RLYGASO-0440000_ST	44
1905553	RLYGASO-0510000_ST	51
1905336	RLYGASO-0570000_ST	57
1905332	RLYGASO-0640000_ST	64
1905529	RLYGASO-0700000_ST	70
1906658	RLYGASO-0760000_ST	76

REV.2.1

// RLYGASO

Fire Protection Sleeve

UL 1441 and VW1 Flame Test Certified

Application: hose and fittings protection from very high temperature.

Specially designed to withstand molten metal splashes.

Material: glass fiber and iron oxide red silicone rubber.

Temperature: - continuous up to +260 °C (500 °F)

- intermittent 15-20 minutes up to 1090 °C (2000 °F)

- Intermittant 15-30 seconds up to 1650 °C (3000 °F)



Item Code	Product Code	ID (mm)
1901117	RLYGASO-0080000	8
1901119	RLYGASO-0100000	10
1902134	RLYGASO-0130000	13
1901103	RLYGASO-0160000	16
1902136	RLYGASO-0190000	19
1902137	RLYGASO-0220000	22
1902547	RLYGASO-0250000	25
1901151	RLYGASO-0290000	29
1902133	RLYGASO-0320000	32
1901153	RLYGASO-0350000	35
1901110	RLYGASO-0380000	38
1901111	RLYGASO-0410000	41
1902135	RLYGASO-0510000	51
1901113	RLYGASO-0570000	57
1901114	RLYGASO-0640000	64
1901156	RLYGASO-0700000	70
1902545	RLYGASO-0760000	76

DNV-GL Certified to 800°C/30mins. (ISO15540 & ISO15541) & DIN EN45545-2

// ROYOT00

Red Smooth Silicone Tape

High Temperature

General: non-adhesive, self-bonding, self-curing, liquid-tight insulation tape.

Application: hose protective tape.

Specially designed to withstand continuous high temperature.

Temperature: -40 °C +246 °C (-40 °F +475 °F)

Notes: Installation: Stretch tape during installation using at least a 50% overlap. For best results, use on clean, dry surfaces free from dirt and oil.



Item Code	Product Code	T (mm)	L (m)	B (mm)
1901101	ROYOT00-0250000	0,6	11,0	25

// PRESSURE WASH

// RGYGMO

**Bend Restrictor
Smooth**



Item Code	ID (mm)	L (mm)	Colour
1901552	12,3		BLK
1901879	13	165	BLU
1901551	17	148	BLU
1901553	17	148	BLK
1900055	17,5	118	BLK
1900056	19,5	150	BLK
1901550	20,6	147	BLU

// RGYGM1

**Bend Restrictor
Corrugated**



Item Code	ID (mm)	L (mm)	Colour
1904987	16	118	BLK
1904988	21	128	BLK



// MACHINES AND TOOLS

// CRIMPING.....	379	// FOAM PROJECTILES.....	389
// HOSE RACK.....	384	// LUNCHERS KITS.....	393
// CUTTING.....	385	// BENDING.....	394
// SKIVING.....	387	// PREASSEMBLY DIN 24.....	395
// HEAT-SHRINKABLE PROTECTION CAPS.....	388		

REV.2.1

// CRIMPING

// CRS-16HP

Portable manual hose crimper with hand pump.



Item Code	Dimensions	Max ID Hose (in)	Crimp. Force (t)	Actuation Type	Crimp Range (mm)
7000084	331X401X271	1"	96	By hand	10 - 45

Also available in pneumatic version (CRS-16AP)

// CRS-16AP

Portable pneumatic hose service crimper.



Item Code	Dimensions	Max ID Hose (in)	Crimp. Force (t)	Actuation Type	Crimp Range (mm)
7000093	331X346X271	1"	96	By hand	10 - 45

// CRS-16HPZ

Manual hydraulic crimping machine for one-off production of hose assemblies (e.g. in repair shops).



Item Code	Dimensions	Max ID Hose (in)	Crimp. Force (t)	Actuation Type	Crimp Range (mm)
7002203	390X331X271	1	96	By hand	10 - 45
7002302	390X331X271	1"	96	By hand	10 - 45

// CRS-20CS

Electric crimping machine specially designed for service van use. They are battery powered with 12V or 24V crimping head on left as standard. Right version available as option.



Item Code	Dimensions	Max ID Hose (in)	Crimp. Force (t)	Actuation Type	Crimp Range (mm)
7002812	583X533X387	1 1/2	137	By hand	10 - 61

Also available as Z-model with separate hydraulic unit for better weight balancing and space usage in service van.

// CRS-20CSZ *NEW*

Electric crimping machine specially designed for service van use. They are battery powered with 12V or 24V crimping head separate from hydraulic power unit



Item Code	Max ID Hose (in)	Crimp. Force (t)	Actuation Type	Crimp Range (mm)
7002341	1 1/2	137	By hand	10 - 61

// CRW-20NMS

Electric crimping machine; strong, fast and reliable for any service crimping need. It turns hydraulics off to conserve energy, and to reduce workplace noise levels whenever the machine is idle



Item Code	Dimensions	Max ID Hose (in)	Crimp. Force (t)	Actuation Type	Crimp Range (mm)
7002445	650X510X620	1 1/2"	137	By hand	10 - 61

Max hose size for Powerflexbio 4K,5K,6K 4-Spiral 1" or consult with PM

REV.2.1

// CRW-32NMS

Electric crimping machine; strong, fast and reliable for any service crimping need. It turns hydraulics off to conserve energy, and to reduce workplace noise levels whenever the machine is idle



Item Code	Dimensions	Max ID Hose (in)	Crimp. Force (t)	Actuation Type	Crimp Range (mm)
7002446	675X520X620	2"	200	By hand	10 - 87

Max hose size for Powerflexbio 4K,5K 4-Spiral 1 1/4" or consult with PM

// CRW-51MS *NEW*

Multi-purpose table top crimping machine for hydraulic and industrial hoses.



Item Code	Dimensions	Max ID Hose (in)	Crimp. Force (t)	Actuation Type	Crimp Range (mm)
7002684	706X473X758	2 1/2"	280	By hand	10 - 124

Max hose size for Powerflexbio 4K&5K 4-6 Spiral 1 1/2"

// CRW-20NMSC

Electric crimping Machine: package solution, with die set and tool rack

Notes: P20NMS + 10pcs of P20 standard dies (from 20-14 to 20-54) and tool rack



Item Code	Dimensions	Max ID Hose (in)	Crimp. Force (t)	Actuation Type	Crimp Range (mm)
7002682	650X510X620	1 1/2"	137	By hand	10 - 61

Max hose size for Powerflexbio 4K,5K,6K 4-Spiral 1" or consult with PM

// CRW-32NMSC

Electric crimping Machine: package solution, with die set and tool rack.

Notes: P32NMS + 10pcs of P20 standard dies (from 20-14 to 20-54) and tool rack



Item Code	Dimensions	Max ID Hose (in)	Crimp. Force (t)	Actuation Type	Crimp Range (mm)
7002683	675X520X620	2"	200	By hand	10 - 87

Max hose size for Powerflexbio 4K,5K 4-Spiral 1 1/4" or consult with PM

// DS-P16 *NEW*

Crimping Machine - Die Set for CRS-16HP, CRS-16HPZ and CRS-16AP



Item Code	L1 (mm)	Crimp Range (mm)
7000100	55,0	10 - 12
7000101	55,0	12 - 14
7000102	55,0	14 - 16
7000103	55,0	16 - 19
7000105	55,0	19 - 23
7000107	55,0	23 - 27
7000109	55,0	27 - 31
7000116	55,0	31 - 38

// DS-P20

Crimping Machine Die Set for CRS-20CS and CRS-20CSZ



Item Code	L1 (mm)	Crimp Range (mm)
7000471	55,0	7 - 10
7000468	55,0	10 - 12
7000469	55,0	12 - 14
7000104	55,0	16 - 19
7000106	55,0	19 - 23
7000108	55,0	23 - 27
7000110	70,0	27 - 31
7000117	70,0	31 - 36
7000118	75,0	36 - 41
7000120	85,0	47 - 54
7000119	75,0	41 - 47
7000121	85,0	54 - 61

REV.2.1

// DS-P32

Crimping Machine Die Set for CRW-32NMS and CRW-32NMSC



Item Code	L1 (mm)	Crimp Range (mm)
7000474	55,0	19 - 22
7000473	55,0	16 - 19
7000475	70,0	22 - 26
7000476	70,0	26 - 30
7000477	70,0	30 - 34
7000479	75,0	39 - 45
7000478	75,0	34 - 39
7000481	90,0	51 - 57
7000480	90,0	45 - 51
7000482	100,0	57 - 63
7002290	110,0	51 - 57
7000483	110,0	63 - 69
7000484	110,0	69 - 75

// DS-140

Crimping Machine - Die Set



Item Code	L1 (mm)	Crimp Range (mm)
7002340	150,0	78 - 80
7002339	150,0	74 - 80

// HOSE RACK

// HRACK-BDL

Hose Rack for Bundle



Item Code	Notes
7002670	1130X940X1893

// HRACK-ROL

Hose Rack for Rolls



Item Code	Notes
7002865	1450X780X1670

REV.2.1

// CUTTING

// CUTS-30CS

Designed for service van use. Manually operated and easy to use, provided with a fume exhaust connection.



Item Code	Motor Power (Kw)	Voltage (V)	Dimensions	Actuation Type	Notes
7002338	3	12V DC	600X503X739	By hand	300MM BLADE

12 or 24V pack available upon request. Max hose size 1 1/4" 2 Wire Braid

// CUTW-CM30

Designed for workshop use. Manually operated and easy to use, provided with a fume exhaust connection.



Item Code	Motor Power (Kw)	Voltage (V)	Dimensions	Actuation Type	Notes
7002304	3	400V AC	600X503X739	By hand	300MM BLADE

Max hose size 2 wire braid

// CUTW-TF1EC

Inexpensive and compact cutting machine, ideal for cutting flexible hydraulic hoses up to 1" four spirals.



Item Code	Motor Power (Kw)	Voltage (V)	Dimensions	Actuation Type	Notes
7002306	0,75	400V AC	516X594X354	By hand	250MM BLADE

// CUTW-TF1E

Inexpensive and compact cutting machine, ideal for cutting flexible hydraulic hoses up to 1" 1/4 four spirals and up to 1" six spirals.



Item Code	Motor Power (Kw)	Voltage (V)	Dimensions	Actuation Type	Notes
7002307	1,1	400V AC	525X660X445	By hand	250MM BLADE

12V power pack available upon request.

// CUTW-TF2E

Ideal for cutting flexible hydraulic hoses up to 2" four spirals and 1" 1/2 six spirals



Item Code	Motor Power (Kw)	Voltage (V)	Dimensions	Actuation Type	Notes
7002308	3	400V AC	650X700X420	By hand	250MM BLADE

REV.2.1

// SKIVING

// SKIVE-S

Skiving Machine Service



Item Code	Weight	Dimensions	Actuation Type
7002342	7	480X240X100	By hand

// SKIVE-MND

Mandrel for external skiving



Item Code	Max ID Hose (in)
7002343	3/8"
7002344	1/2"
7002345	3/4"
7002346	3/4"

// SKIVE-W

Skiving Machine Workshop



Item Code	Weight	Motor Power (Kw)	Voltage (V)	Dimensions	Actuation Type
7002833	34	0,75	400V AC	821X366X390	By hand

// HEAT-SHRINKABLE PROTECTION CAPS

// HEAT-CAP

Heat-Shrinkable Protection Caps



Item Code	Colour	Notes
1904867	BLU	18-23MM
1904868	BLU	24-29MM
1904865	BLU	12-18 MM
1904870	BLU	41-50MM
1904869	BLU	30-36MM
1904873	BLU	64-78MM
1904872	BLU	55-65MM
1904866	BLU	16-21MM
1904871	BLU	49-56MM

REV.2.1

// FOAM PROJECTILES

// FOAM-P-MD

Foam Projectiles - Medium Density



Item Code	Size (mm)	Colour	Notes
7000166	5	WHT	100 PCS BAG
7002448	6	WHT	100 PCS BAG
7000168	7	WHT	100 PCS BAG
7000169	8	WHT	100 PCS BAG
7000170	10	WHT	100 PCS BAG
7000172	12	WHT	100 PCS BAG
7000162	14	WHT	100 PCS BAG
7002449	16	WHT	100 PCS BAG
7000145	18	WHT	100 PCS BAG
7002450	20	WHT	50 PCS BAG
7000167	22	WHT	50 PCS BAG
7002451	24	WHT	50 PCS BAG
7000161	26	WHT	50 PCS BAG
7002452	28	WHT	40 PCS BAG
7002453	30	WHT	40 PCS BAG
7000142	33	WHT	40 PCS BAG
7002454	36	WHT	30 PCS BAG
7000144	40	WHT	40 PCS BAG
7002455	45	WHT	20 PCS BAG
7000143	50	WHT	20 PCS BAG
7000164	55	WHT	15 PCS BAG
7002456	60	WHT	15 PCS BAG
7000155	65	WHT	10 PCS BAG
7002457	70	WHT	10 PCS BAG
7002458	75	WHT	10 PCS BAG
7002459	80	WHT	10 PCS BAG
7002460	85	WHT	10 PCS BAG
7002461	90	WHT	10 PCS BAG
7002462	95	WHT	10 PCS BAG
7002463	100	WHT	10 PCS BAG

// FOAM-P-HD

Foam Projectiles - High Density



Item Code	Size (mm)	Colour	Notes
7002464	6	WHT	100 PCS BAG
7002465	7	WHT	100 PCS BAG
7002466	8	WHT	100 PCS BAG
7002467	10	WHT	100 PCS BAG
7002468	12	WHT	100 PCS BAG
7002469	14	WHT	100 PCS BAG
7002470	16	WHT	100 PCS BAG
7002471	18	WHT	100 PCS BAG
7002472	20	WHT	50 PCS BAG
7002473	22	WHT	50 PCS BAG
7002474	24	WHT	50 PCS BAG
7002475	26	WHT	50 PCS BAG
7002476	28	WHT	40 PCS BAG
7002477	30	WHT	40 PCS BAG
7002478	33	WHT	40 PCS BAG
7002479	36	WHT	30 PCS BAG
7002480	40	WHT	30 PCS BAG
7002481	45	WHT	20 PCS BAG
7002482	50	WHT	20 PCS BAG
7002483	55	WHT	15 PCS BAG
7002484	60	WHT	15 PCS BAG
7002485	65	WHT	10 PCS BAG

REV.2.1

// FOAM-P-A

Foam Projectiles - Abrasive

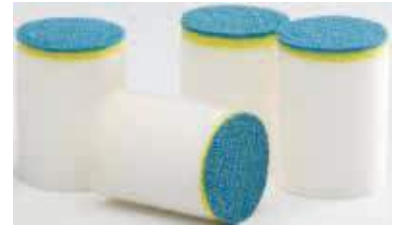

Item Code	Size (mm)	Colour	Notes
7002486	6	WHT/BLU	100 PCS BAG
7002487	7	WHT/BLU	100 PCS BAG
7002488	10	WHT/BLU	100 PCS BAG
7002489	12	WHT/BLU	100 PCS BAG
7002490	14	WHT/BLU	100 PCS BAG
7002491	16	WHT/BLU	100 PCS BAG
7002492	18	WHT/BLU	100 PCS BAG
7002493	20	WHT/BLU	50 PCS BAG
7002494	22	WHT/BLU	50 PCS BAG
7002495	24	WHT/BLU	50 PCS BAG
7002496	26	WHT/BLU	50 PCS BAG
7002497	28	WHT/BLU	40 PCS BAG
7002498	30	WHT/BLU	40 PCS BAG
7002499	33	WHT/BLU	40 PCS BAG
7002500	36	WHT/BLU	30 PCS BAG
7002501	40	WHT/BLU	30 PCS BAG
7002502	45	WHT/BLU	20 PCS BAG
7002503	50	WHT/BLU	20 PCS BAG
7002504	55	WHT/BLU	15 PCS BAG
7002505	60	WHT/BLU	15 PCS BAG
7002506	65	WHT/BLU	10 PCS BAG
7002507	70	WHT/BLU	10 PCS BAG
7002508	75	WHT/BLU	10 PCS BAG
7002509	80	WHT/BLU	10 PCS BAG
7002510	85	WHT/BLU	10 PCS BAG
7002511	90	WHT/BLU	10 PCS BAG
7002512	95	WHT/BLU	10 PCS BAG
7002513	100	WHT/BLU	10 PCS BAG
7002514	110	WHT/BLU	10 PCS BAG

// FOAM-P-US

Foam Projectiles - Ultra Scrub



Item Code	Size (mm)	Colour	Notes
7002515	6	WHT/YEL	100 PCS BAG
7002516	7	WHT/YEL	100 PCS BAG
7002517	8	WHT/YEL	100 PCS BAG
7002518	10	WHT/YEL	100 PCS BAG
7002519	12	WHT/YEL	100 PCS BAG
7002520	14	WHT/YEL	100 PCS BAG
7002521	16	WHT/YEL	100 PCS BAG
7002522	18	WHT/YEL	100 PCS BAG
7002523	20	WHT/YEL	50 PCS BAG
7002524	22	WHT/YEL	50 PCS BAG
7002525	24	WHT/YEL	50 PCS BAG
7002526	26	WHT/YEL	50 PCS BAG
7002527	28	WHT/YEL	40 PCS BAG
7002528	30	WHT/YEL	40 PCS BAG
7002529	33	WHT/YEL	40 PCS BAG
7002530	36	WHT/YEL	30 PCS BAG
7002531	40	WHT/YEL	30 PCS BAG
7002532	45	WHT/YEL	20 PCS BAG
7002533	50	WHT/YEL	20 PCS BAG
7002534	55	WHT/YEL	15 PCS BAG
7002535	60	WHT/YEL	15 PCS BAG

REV.2.1

// LUNCHERS KITS

// CLEAN-GUNA

Cleaning Gun Kit

Launcher and 8 nozzles



Item Code	Notes
7002284	1/4" - 1 1/4"

// CLEAN-GUNB

Cleaning Gun Kit

Launcher, Launcher Stand, 20 Nozzles 1/4" - 2" Air Clean Projectiles



Item Code	Notes
7002285	1/4" - 2"

// BENDING

// PIPEBEND-M

Pipe Bending Manual

Tube: 6 to 18 mm

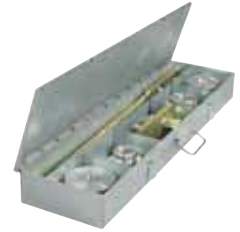

Item Code	Weight	Notes
7000189	10	720X190X80

REV.2.1

// PREASSEMBLY DIN 24

// PRE-DINL-M

Pre-assembly DIN 24° Manual
Light Series

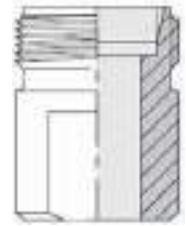

Item Code	Notes
7000216	06L
7000507	08L
7000208	10L
7000209	12L
7000211	15L
7000508	18L
7000214	22L
7000509	28L
7000872	35L
7000215	42L

// PRE-DINS-M

Pre-assembly DIN 24° Manual
Heavy Series

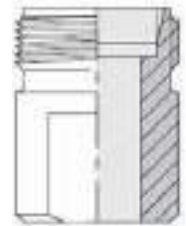

Item Code	Notes
7000217	06S
7000510	08S
7000549	10S
7000210	12S
7000511	14S
7000212	16S
7000213	20S
7000712	25S
7000876	30S
7000875	38S

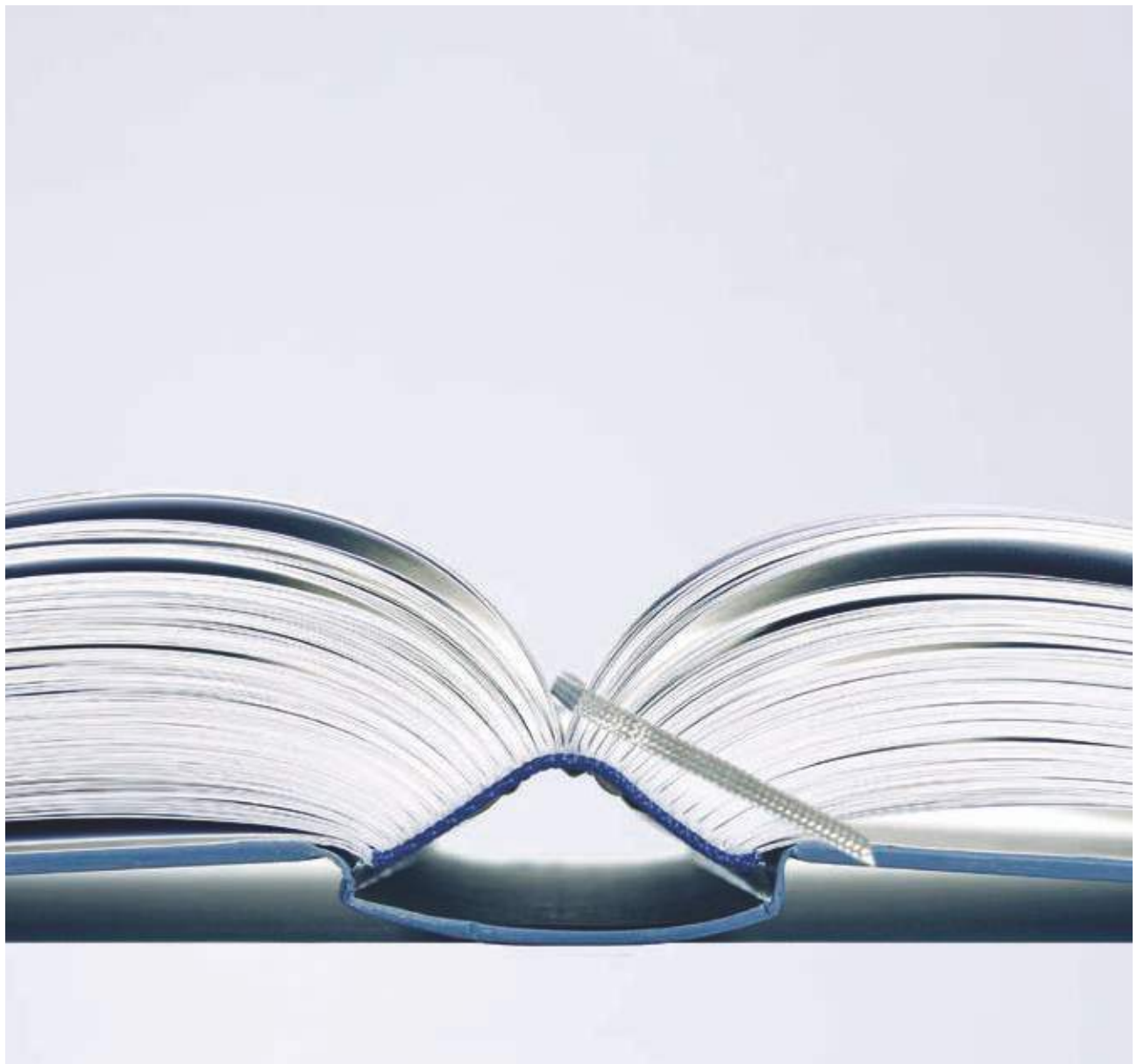

// APPENDIX

// HOSE GUIDELINE.....	397	// ADAPTERS GUIDELINES.....	421
// FITTINGS GUIDELINES.....	407	// INDEX.....	426

// HOSE GUIDELINE

SETTING NEW STANDARD

Dunlop Hiflex cares for the environment and for your equipment among Dunlop Hiflex's newest products are Powerflexbio 3000, 4000, 5000, 5000 PLUS, 6000 spiral hose, low temperature, Temp Tech, MineTuff, SuperTuff hose and a complete coupling line.

They join the extensive range of Dunlop Hiflex hose, the high pressure hydraulic components that have set the standard for reliability and durability.

DESIGN

Throughout the world, Dunlop Hiflex has built up a name synonymous with quality, a reputation based on first class product, a commitment to research and development and ongoing capital investment.

The development and product engineering staff in Dunlop Hiflex, continue to provide fluid conveying product innovations that assure better performance and cost saving to our customers.

Dunlop Hiflex hose and couplings are designed to work together as a system for problem free performance, no matter what machine you operate.

The performance of all our products exceeds SAE, DIN, JIS requirements and some hoses meet the MSHA and LOBA flame resistance requirements, as well.

LEADERSHIP IN HYDRAULIC HOSE AND COUPLING COMPONENTS

Dunlop Hiflex has developed into a world leading manufacturer of fluid power and fluid system components. A positive attitude towards the demands of new equipment which is using the latest technology has seen Dunlop Hiflex introduce many outstanding new hydraulic hose types. These hoses have found acceptance in a wide range of industries, some examples are: Mining, Logging, Petroleum, Railroad, Construction, Earthmoving, Agriculture, Waste/Refuse, Manufacturing, Pulp and Plywood Mills, Moulding, Drilling, Crane

GLOBAL COMPANY

Due to our world-wide organisation of subsidiaries and distributors you will always be near a source for Dunlop Hiflex products. Your Dunlop Hiflex dealer has trained personnel to consult with you on your hose and coupling requirements guaranteeing consistent quality and performance.

OUR COMMITMENT

By remaining alert to customer's needs, Dunlop Hiflex is constantly engineering new products for tomorrow's markets as well as modifying them for even higher performances.

Dunlop Hiflex commitment to innovation and service makes our products known throughout the world for quality, reliability and leadership, when you need quality hose and couplings, use the best available.

Now you can count on Dunlop Hiflex for all your needs.

TESTING

Dunlop Hiflex laboratories are fully equipped to carry out tests according to standards like SAE, ISO, DIN and JIS. New products are also subjected to laboratory simulation of actual service prior to being released on the market.

WORLD CLASS QUALITY

Dunlop Hiflex is working to adhere to internationally recognised quality programmes requiring stringent standards.

Many of our customers are demanding ISO qualification or equivalent as a prerequisite for purchasing. This standard is an assurance of consistent quality. For Dunlop Hiflex this is just the start "do it right from the beginning".

IMPORTANT NOTE FOR USERS

Hose assemblies require caution in use not only to provide long service life but also to guard against potentially dangerous failure.

Serious injury, death and destruction of property can result from the rupture or blowing-apart of a hydraulic hose assembly that is damaged, worn out, badly assembled or installed incorrectly.

Users should follow good maintenance practices. Avoid expensive downtime by establishing a program of inspection, testing and replacement of hose assemblies before failure occurs; taking into account factors including: severity of application, frequency of equipment use, past performance of hose assemblies. Document your maintenance, inspections and testing.

Only properly trained persons should inspect, test or service hose assemblies and this training should be updated regularly.

Users should carefully observe the precautions listed below under "be aware that" as well as follow closely our recommendations for the selection of hose and couplings. In addition, care should be taken not to exceed the minimum bend radius listed for each hose size and type.

Maximum operating pressure should not exceed the pressures listed. Instruction for assembling fittings to different hoses should be followed carefully to ensure the safe performance of the complete assembly.

By following the recommendations on hose assembly routing and installation, improved safety and longer service life of any hose installation will result.

Hydraulic fluid under pressure can be potentially dangerous!! An explosive burst or stream of escaping fluid can cause damage to equipment as well as serious injury to persons nearby.

BE AWARE THAT...

1. Highly pressurised fluid escaping from a small pinhole can be almost invisible and, yet, exert extreme force capable of penetrating the skin and other body tissues, causing possible severe injury.
2. Hot fluids or chemicals can cause severe burns.
3. Pressurised fluids, if released uncontrolled, can exert a tremendous explosive force.
4. All hydraulic hoses listed in this catalogue are electrically conductive.
5. Some hydraulic fluids are highly flammable.

AND...

6. Always position a shield between you and any pressurised hydraulic lines when working next to them... or shut the pressure off.
7. Wear safety glasses.
8. Do not use your hands to check for leaks. Do not touch a pressurised hydraulic hose assembly with any part of your body, if fluid punctures the skin, even if no pain is felt, a serious emergency exists. Obtain medical assistance immediately. Failure to do so can result in loss of the injured body part or death.
9. Stay out of hazardous areas while testing hose assemblies under pressure. Use proper safety protection.
10. If an injury or reaction occurs, get medical attention right away.
11. Use only non conductive thermoplastic hoses where electrical conductivity is not desired: for instance, equipment working on electric power lines.

Dunlop Hiflex hose and fitting are designed, engineered and tested to be used together in an assembly.

The use of Dunlop Hiflex fittings on other manufactures hose or the use of Dunlop Hiflex hose with other manufactures fittings may result in the production of unreliable or unsafe assemblies. It is neither recommended nor authorised by Dunlop Hiflex.

Dunlop Hiflex recommends only those hose and coupling combinations specified in the Dunlop Hiflex Hydraulic Products Catalogues.

Dunlop Hiflex disclaims any liability for any hose assemblies which have not been produced in conformance with Dunlop Hiflex assembly recommendations and current crimp data charts. Extensive impulse testing has been performed by Dunlop Hiflex to verify the recommendations contained in this catalogue. A simple burst or pressure test cannot determine a hose and coupling combination.

Any claim for defects must be made in writing on the appropriate ISO 9001 complaint form within 8 days from receipt of the product. Dunlop Hiflex will have a reasonable opportunity thereafter to examine and investigate the alleged defect.

The customer's exclusive remedy with respect to any claim of any kind whatsoever shall be refund of the purchase price or replacement of the product at the option of Dunlop Hiflex and in no event shall Dunlop Hiflex be liable for any incidental or consequential damages whatsoever.

REFERENCE SPECIFICATIONS

SAE	Society of Automotive Engineers
DNV-GL	Det Norske Veritas - Germanischer Lloyd
EN	European Norm
DIN	Deutsche Institute Normen
CERCHAR	Centre d'Etudes et Recherches des Charbonnages de France
MSHA	U.S. Mine Safety and Health Administration

LOBA	Landesobergamt Nordrhein - Westfalen
AS	Australian Standard
BV	Bureau Veritas
ISO	International organization for Standardization
KR	Korean Register
MA	Chinese Mining

The listings below are intended only as guides in identifying which Dunlop Hiflex hoses comply with requirements of various agencies.

Hose	SAE J517	EN	ISO	Dunlop Hiflex Proprietary Hose	DNV GL	ABS	BV	NKK	RINA	Lloyd's Register	MSHA ²	USDOT ³	KR	MA
Argus 1TE/R6 HF	100 R6	EX 854 1TE (up to 3/4")												
Argus 2TE HF		854 2TE												
Argus 3TE/R3 HF	100 R3	854 3TE												
Flexor 7	100 R7	855 R7	3949											
Flexor 8	100 R8	855 R8												
2TE Railway		854 2TE 45545-2												
2SC Railway		854 2SC 45545-2	11237											
122T Greenline Plus - 1SN/R1AT	100 R1AT	853 1SN	1436-1		●	●		●*		●				●
222T Greenline Plus - 2SN/R2AT	100 R2AT	853 2SN	1436-1		●	●		●*	●	●				●
221T Slimline Plus		857 2SC	11237		●	●	●	●*						
121T Slimline Plus - 1SC		857 1SC	11237		●		●							
241T Superslimline	100 R16	857 2SC (up to 1")	11237		●	●	●	●	●	●	●			●
AT7K - 490 Powertrak				●							●			
AT8K - 560 Powertrak				●							●			
Powerflexbio 3000	EX SAE R12		18752	●	●	●	●	●*	●	●	●			
Powerflexbio 4000			18752	●	●	●	●	●*	●	●	●			
Powerflexbio 5000			18752 (except for DN 76)	●	●	●	●	●*	●	●	●			
Powerflexbio 5000P			18752	●	●	●	●	●*	●	●	●			
Powerflexbio 6000	EX SAE R15		18752	●	●	●	●	●*	●	●	●			
Firesafe 5000				●	●					●	●			
Commander 150 1SN PLUS	100 R1AT	853 1SN	1436-1	●										
SP33G - Superforest				●	●	●	●	●		●				●
261E - Hypercold Superslimline														
SP33E - Hypercold Superforest														
Flexor R4	100 R4						●							

* Running

1. DNV approvals are with permanent (crimp) type fittings only
2. Hoses with MSHA approved cover are always branded "MSHA"
3. DOT Type all TYPE AII FMVSS 106 approval up to 3/4"

Listing may vary by style and size, for current and complete information, contact Dunlop Hiflex for details.

SAFETY GUIDE BASIC FACTORS FOR THE SELECTION, INSTALLATION AND MAINTENANCE OF HOSE AND HOSE ASSEMBLIES

Hydraulic hose (and hose assemblies) has a limited life dependent on service conditions to which is applied.

Subjecting hose (and hose assemblies) to conditions more severe than the recommended limits significantly reduce service life. Exposure to combinations of recommended limits (i.e., continuous use at maximum rated working pressure, maximum recommended operating temperature and minimum bend radius) will also reduce service life.

WARNING: FAILURE TO FOLLOW PROPER SELECTION, INSTALLATION AND MAINTENANCE PROCEDURES MIGHT RESULT IN BODILY INJURY, AND DAMAGE TO PROPERTY.

1. SELECTION

The following is a list of factors which must be considered before the selection of a hose can be made:

1.1 Line size

In order to achieve maximum efficiency in a hydraulic system, it is necessary to keep pressure losses (resistance to the volumetric flow) to a minimum when a fluid is conveyed by the different types of flow lines. When a fluid flows through a flow line, heat is generated by friction. Thus part of the energy is lost as heat energy, which results in a pressure loss.

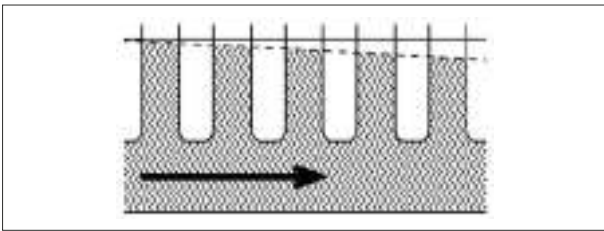

These pressure losses depend upon:

- flow velocity (for a given volumetric flow, the fluid flow velocity increases with a decrease in the cross sectional area of a flow line and vice versa)
- length of the flow line
- the viscosity of the fluid flowing
- the density of the fluid flowing
- the type of flow (laminar or turbulent)

Types of flow - The type of flow changes from laminar to turbulent at a certain flow velocity. This velocity is given by the Reynold's Number Re.

For cylindrical flow lines the following formula applies:

$$Re = \frac{v \times d}{\nu}$$

- where:
- v = velocity (m/s)
 - d = flow line internal dia (m)
 - ν = kinematic viscosity (m²/s)

As soon as the value for Re exceeds 2300, the laminar flow changes to turbulent flow.

Laminar flow - In laminar flow, the individual fluid particles move up to certain speeds in uniform layers alongside each other. They scarcely disturb or influence each other.

Turbulent flow - If the value for Re exceeds 2300, flow becomes whirling and turbulent. The individual particles no longer move in one direction in an orderly fashion, but influence and hinder each other.

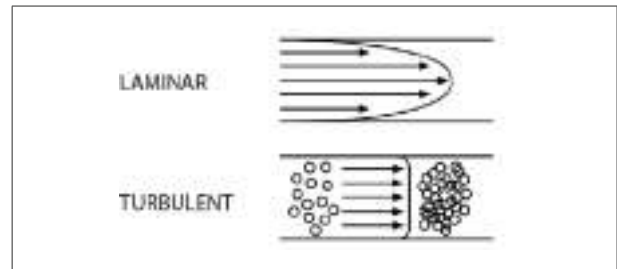

Certain fluid flow velocities have proved to be most suitable for hydraulic flow lines.

Recommended flow velocities:

Suction lines:	0.5 ... 1.2 m/s	1.6 ... 4 feet/s
Return lines:	2 ... 3 m/s	6.5 ... 10 feet/s
Pressure lines:	4 ... 7.5 m/s	13...25 feet/s

FLOW CAPACITY NORMOGRAM

Flow Capacities of Hose at Recommended Flow Velocities

The chart below is provided as an aid in the determination of the correct hose size.

Example at 45 l/min, what is the proper hose size within the recommended velocity range for pressure lines?

Locate 45 l/min in the left-hand column and 7,5 m/s in the right-hand column (the maximum recommended velocity range for pressure lines).

Lay a straight line across these two points. The inside diameters shown in the centre column is above 9,5 mm so we have to use 12,7 mm (1/2"). For suction hose, follow the same procedure except use recommended velocity range for intake lines in the righthand column.

- where:
- Q = flow in liters per seconds (l/sec)
 - V = velocity in meters per seconds (m/s)
 - d = hose inside diameter (mm & dash size)

TECHNICAL INFORMATION – NORMOGRAM OF THE FLOW

The normogram herewith is pivotal to help you find the hose diameter by knowing the liquid flow and speed. In order to find the correct diameter you should trace a line between the flow value (l/min) and the suggested speed (m/sec) according to the kind of delivery (pressure or return). The value touched by the line in the central column will indicate the hose ID (mm/inches) that must be used.

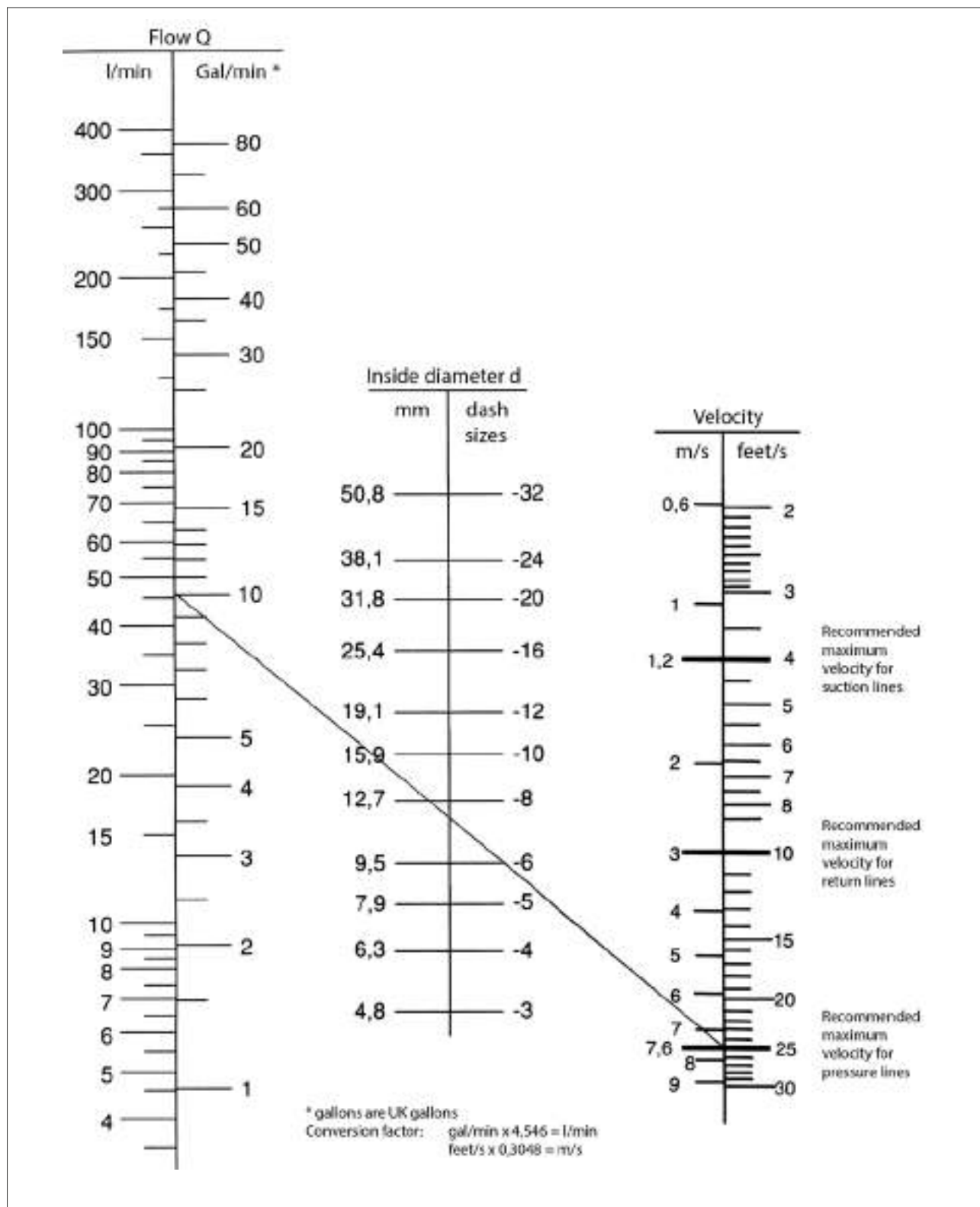

It is therefore important to calculate correctly the required flow line sizes. Undersized pressure lines results in high fluid velocity causing an excessive pressure drop, and heat built up, which impair overall system performance.

Undersized suction lines can cause cavitation at the hydraulic pump inlet, affecting performance, shortening pump life, and creating excessive noise levels.

The flow capacity normogram is an aid to determine the correct hose internal diameter size, desired flow rate and recommended velocity. By the use of any two known factors, the third can be determined.

1.2 Pressure

After determining the system pressure for a hydraulic system, hose selection must be made so that the recommended maximum operating pressure specified by a given hose, is equal or greater than the system pressure. Dynamic pressure is common for all hydraulic systems. Pressure surges which exceed the maximum working pressure (pressure relief valve setting) affect the service life of system components, including a hose assembly and therefore need to be taken into consideration. Hoses used for suction lines must be selected to ensure the hose will withstand the negative pressure of the system.

1.3 Temperature

Care must be taken to ensure that the operating temperature of the fluid being conveyed and ambient temperatures, do not exceed the limitations of the hose. Special care must be taken when routing near hot manifolds or molten metal.

1.4 Fluid Compatibility

Hose selection must assure compatibility of the hose tube, cover, reinforcement, and fittings with the fluid used.

Additional caution must be observed in hose selection for gaseous applications. Some fire resistant fluids require the same hose as petroleum oil. Some use a special hose, while a few fluids will not work with any hose at all.

For gas application, where compatible with Dunlop Hiflex Hoses, and at pressure above 10 bar, the hose cover shall be pin-pricked.

1.5 Permeation

Permeation (that is, seepage through the hose) will occur from inside the hose to outside when hose is used with gases, liquid and gas fuels, and refrigerants (including but not limited to such materials such as helium, fuel oil, natural gas or freon). This permeation may result in high concentrations of vapours which are potentially flammable, explosive, or toxic and in loss of fluid. Even though the fluid compatibility is acceptable, you must take into account the fact that permeation will occur and could be hazardous. Permeation of moisture from outside the hose to inside the hose will also occur. If this moisture permeation would have detrimental effects (particularly but not limited to refrigeration and air conditioning systems), incorporation of sufficient drying capacity in the system or other appropriate system safeguards should be selected and used.

1.6 Routing

Attention must be given to optimum routing to minimise inherent problems. Restrain, protect or guide hose with the use of clamps if necessary to minimise risk or damage due to excessive flexing, whipping or contact with other moving parts or corrosives. Determine hose lengths and configurations that will result in proper routing and protection from abrasion, snagging or kinking and provide leak resistant connections.

1.7 Environment

Care must be taken to ensure that the hose and fittings are either compatible with or protected from the environment to which they are exposed. Environmental conditions including

but not limited to ultraviolet light, heat, ozone, moisture, water, salt water, chemicals, and air pollutants can cause degradation and premature failure and, therefore, must be considered.

1.8 Mechanical Loads

External forces can significantly reduce hose life. Mechanical loads which must be considered include excessive flexing, twist, kinking, tensile or side loads, bend radius, and vibration. Use of swivel type fittings or adaptors may be required to ensure no twist is put into the hose. Unusual applications may require special testing prior to hose selection.

1.9 Abrasion

While a hose is designed with a reasonable level of abrasion resistance, care must be taken to protect the hose from excessive abrasion which can result in erosion, snagging, and cutting of the hose cover. Exposure of the reinforcement will significantly accelerate hose failure.

1.10 Proper End Fitting

Care must be taken to ensure proper compatibility exists between the hose and coupling selected based on the manufacturer's recommendations substantiated by testing to industry standards such as SAE J517, DIN 20024, JIS B 8360.

1.11 Length

When establishing proper hose length, motion absorption, hose length changes due to pressure, as well as hose and machine tolerances must be considered.

1.12 Specifications and Standards

When selecting hose and fittings, government, industry, and manufacturer's specifications and recommendations must be reviewed as applicable.

1.13 Hose Cleanliness

Hose components may vary in cleanliness levels. Care must be taken to ensure that the assemblies selected have an adequate level of cleanliness for the application.

1.14 Welding and Brazing

Heating of plated parts, including hose fittings and adaptors, above 232° C (450° F) such as during welding, brazing, or soldering may emit deadly gases.

1.15 Electrical Conductivity

Certain applications require that a hose be non-conductive to prevent electrical current flow. Other applications require the hose to be sufficiently conductive to drain off static electricity. Extreme care must be exercised when selecting hose and fittings for these or any other applications in which electrical conductivity or non-conductivity is a factor. For applications that require hose to be electrically non-conductive, including but not limited to applications near high voltage electric lines, only special non-conductive hose is to be used. The manufacturer of the equipment in which the non-conductive hose is to be used must be consulted to be certain that the hose and fittings that are selected are proper for the application.

Do not use any Dunlop Hiflex hose or fitting for any application requiring non-conductive hose, including but not limited to applications near high voltage electric lines, unless the application is expressly approved in the Dunlop Hiflex technical publication for the product, the SAFETY GUIDE hose is both orange in colour and marked "non-conductive", and the manufacturer of the equipment on which the hose is to be used specifically approves the particular Dunlop Hiflex hose and fitting for such use. Dunlop Hiflex does not supply any hose or fittings for conveying paint in airless paint spraying or similar applications and therefore should not be used. A special hose and fitting assembly is required for this application, to avoid static electricity buildup which could cause a spark that may

results in an explosion and/or fire. The electrical conductivity or non-conductivity of hose and fittings is dependant upon many factors and may be susceptible to change. These factors include but are not limited to the various materials used to make the hose and the fittings, manufacturing methods (including moisture control), how the fittings contact the hose, age and amount of deterioration or damage or other changes, moisture content of the hose at and particular time, and others factors.

2. INSTALLATION

After the selection of the correct hose, the following factors must be considered prior to hose and fitting assembly and installation.

2.1 Pre-Installation Inspection

Prior to installation, a careful examination of the hose must be performed. All components must be checked for correct style, size, and length. The hose must be examined for cleanliness, obstructions, blisters, cover looseness, or any other visible defects.

2.2 Hose and Fitting Assembly

Do not assemble a Dunlop Hiflex fitting on a Dunlop Hiflex hose that is not specified by Dunlop Hiflex for that hose. Do not assemble Dunlop Hiflex fittings on another manufacturer's hose or a Dunlop Hiflex hose on another manufacturer's fitting unless Dunlop Hiflex approves the assembly in writing, and the user verifies the assembly and the application through analysis and testing.

The Dunlop Hiflex published hose assembly instructions must be followed for assembling the fittings on the hose.

2.3 Related Accessories

Crimp or swage Dunlop Hiflex hose or fittings only with Dunlop Hiflex approved swage or crimp machines and in accordance with the Dunlop Hiflex published hose assembly instructions.

2.4 Parts

Do not use any Dunlop Hiflex hose fitting part (including but not limited to sockets, or inserts) except with the correct Dunlop Hiflex mating parts, in accordance with Dunlop Hiflex published hose assembly.

2.5 Reusable/Permanent

Do not reuse any reusable hose coupling that has blown or pulled off a hose. Do not reuse a Dunlop Hiflex permanent (that is, crimped or swaged) hose fitting or any part thereof.

2.6 Minimum Bend Radius

Installation of a hose at less than the minimum listed bend radius may significantly reduce the hose life. Particular attention must be given to avoid sharp bending at the hose/fitting juncture.

2.7 Twist Angle and Orientation

Hose installations must be such that relative motion of machine components does not produce twisting.

2.8 Securement

In many applications, it may be necessary to restrain, protect, or guide the hose to protect it from damage by unnecessary flexing, pressure surges, and contact with other mechanical components. Care must be taken to ensure such restraints do not introduce additional stress or wear points.

2.9 Proper Connection of Ports

Proper physical installation of the hose requires a correctly installed port connection while ensuring that no twist or torque is transferred to the hose.

2.10 External Damage

Proper installation is not complete without ensuring that tensile loads, side loads, kinking, flattening, potential abrasion, thread damage, or damage to sealing surfaces are corrected or eliminated.

2.11 System Checkout

After completing the installation all air entrapment must be eliminated and the system pressurised to the maximum system pressure and checked for proper function without any leaks. Personnel must stay out of potential hazardous areas while testing.

3. HOSE AND FITTING MAINTENANCE INSTRUCTIONS

Even with proper selection and installation, hose life may be significantly reduced without a continuing maintenance program. Frequency should be determined by the severity of the application and risk potential. A maintenance program must be established and followed to include the following as a minimum:

3.1 Visual Inspection Hose/Fitting

Any of the following conditions require immediate shut down and replacement of the hose assembly:

- Fitting slippage on hose.
- Damaged, cut or abraded cover (any reinforcement exposed).
- Hard, stiff, heat cracked, or charred hose.
- Cracked, damaged, or badly corroded fittings.
- Leaks at fitting or in hose.
- Kinked, crushed, flattened or twisted hose.
- Blistered, soft, degraded, or loose cover.

3.2 External Damage

Proper installation is not complete without ensuring that tensile loads, side loads, kinking, flattening, potential abrasion, thread damage, or damage to sealing surfaces are corrected or eliminated.

3.3 System Checkout

After completing the installation all air entrapment must be eliminated and the system pressurised to the maximum system pressure and checked for proper function without any leaks. Personnel must stay out of potential hazardous areas while testing.

3.4 Visual Inspection All Other

The following items must be tightened, repaired or replaced as required:

- Leaking port conditions
- Remove excess dirt build-up
- Clamp, guards, shields
- System fluid level, fluid type and any air entrapment

3.5 Functional Test

Operate the system at maximum operating pressure and check for possible malfunctions and freedom from leaks. Personnel must stay out of potential hazardous areas while testing.

3.6 Replacement Intervals

Specific replacement intervals must be considered based on previous service life, government or industry recommendations, or when failures could result in unacceptable downtime, damage, or injury risk.

CORRECT ASSEMBLY INSTALLATION

Satisfactory performance and appearance depend upon proper hose installation. Excessive length destroys the trim appearance of an installation and adds unnecessarily to the cost of the equipment. Hose assemblies of insufficient length to permit adequate flexing, expansion or contraction will cause poor power transmission and shorten the life of the hose. The diagrams below offer suggestions for proper hose installations to obtain the maximum in performance and economy.

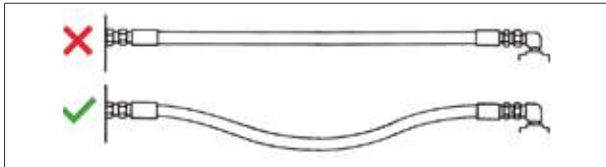

Since hose may change in length from +2% to -4% under the surge of high pressure, provide sufficient slack for expansion and contraction.



Avoid sharp twist or bend in hose by using proper angle adapters.



Where the radius falls below the required minimum, an angle adapter should be used as shown above to avoid sharp bends in hose.

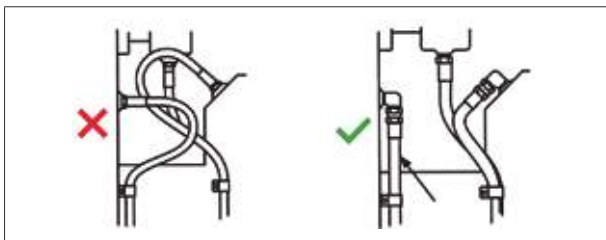

Obtain direct routing of hose through use of 45° and 90° adapters and fittings. Improve appearance by avoiding excessive hose length.

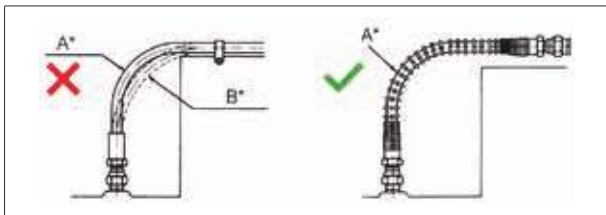

A: High Pressure - B: No Pressure
Due to changes in length when hose is pressurised, do not clamp at bends so curves absorb changes and protect the hose with a spring guard. Do not clamp high and low pressure lines together and protect the hose with a spring guard.

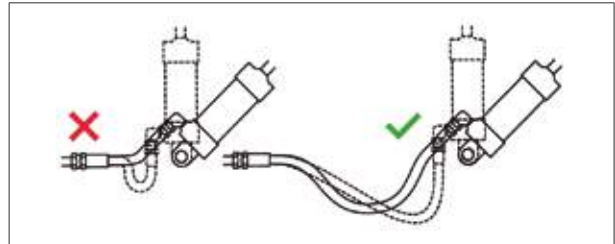

Adequate hose length is most important to distribute movement on flexing applications and to avoid abrasion.

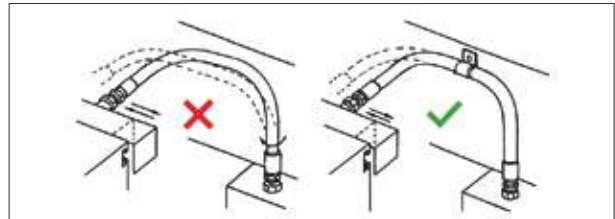

To avoid twisting in hose lines bent in two planes, clamp hose at change of plane, as shown.

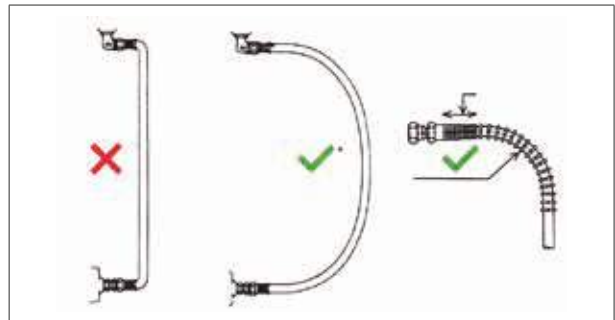

* Never use a banding radius less than the minimum amount shown in the table. To prevent twisting and distortion, hose should be bent in the same plane as the motion of the boss to which the hose is connected.

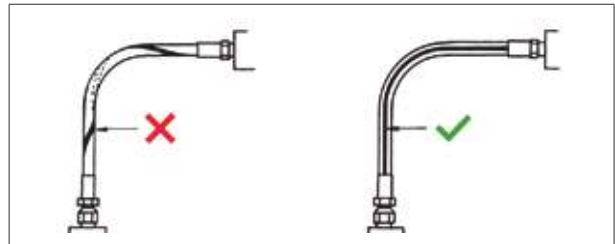

Hose should not be twisted. Hose is weakened when installed in twisted position. Also pressure in twisted hose tends to loosen fitting connections. Design so that machine motion produces bending rather than twisting.

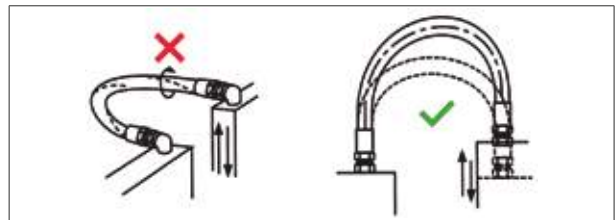

Never use a bending radius less than the minimum shown in the hose specification tables. Avoid sharp bend in hose to reduce collapsing of line and restriction of flow by using proper spring guard. Exceeding minimum bend radius will greatly reduce hose assembly life.

HOW TO DETERMINE CORRECT ASSEMBLY LENGTH

For most assemblies, the correct assembly length may be determined by direct measurement of the equipment or a drawing. Minimum bend radii as shown in the hose specification tables should be observed.

Assemblies are measured to the end of the seal.

To determine the length of hose needed in making assemblies with permanent or reusable couplings, subtract Dimension "C" (Cut off factor) for each coupling from the required overall assembly length. Dimension "C" may be found in the coupling specification tables.

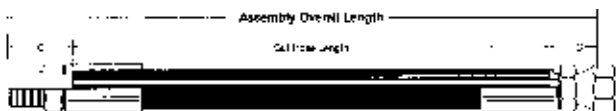

HOW TO MEASURE ASSEMBLIES

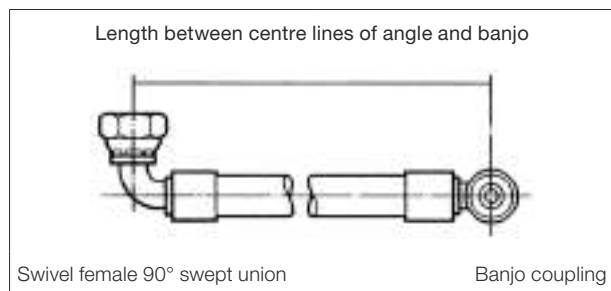
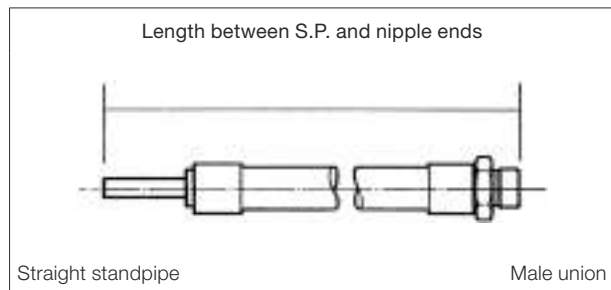
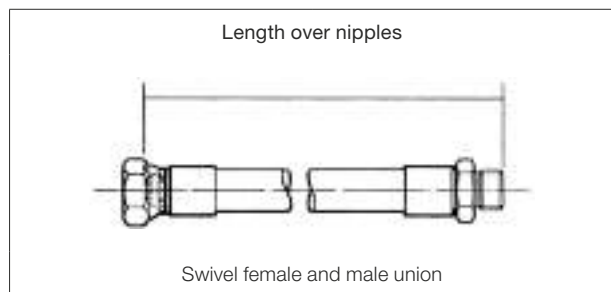

Remember that hydraulic hose under pressure will elongate up to 2% of its length or contract up to 4% depending on pressure, type and size. Sufficient allowance should be made to permit such changes in length.

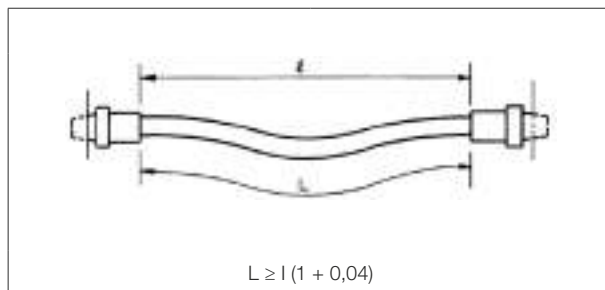
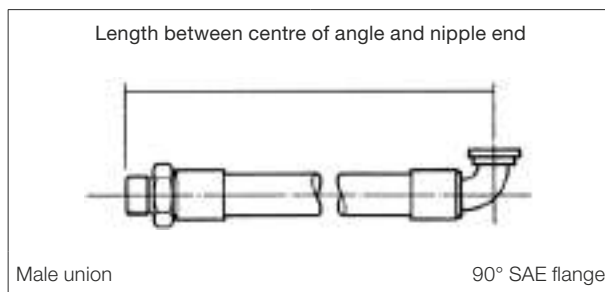
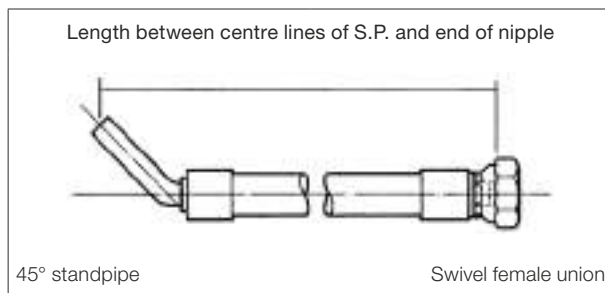
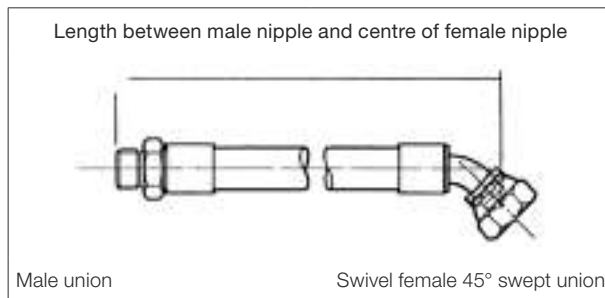

Occasionally an assembly will be required similar to the sketches to the right. The following equations are helpful in determining the correct length:

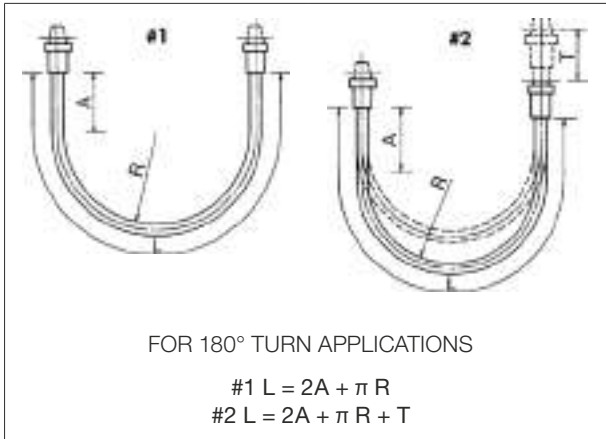

where:

L = overall length of the hydraulic hose assembly, in mm or inches.

A = allowance for a minimum straight section of hydraulic hose at each end of the assembly, measured from the outer end of each coupling, in mm or inches. These two straight sections are necessary to prevent excessive stress concentrations directly back of the couplings. See table below.

R = bending radius of the hose, in mm or inches. See hose specifications tables.

T = amount of travel, in mm or inches.

Often right angle adapters provide a convenient means of avoiding too small a bend radius.

Hose ID	in	1/4	5/16	3/8	1/2	5/8	3/4	1	1.1/4	1.1/2	2
	mm	6,4	7,9	9,5	12,7	15,9	19	25	31,8	38,1	50,8
Min "A"	in	5	5	5	6	6	7	8	9	10	11
	mm	127	127	127	152	152	178	203	229	254	279

Length Tolerance for Hydraulic Hose Assemblies and Specified Hose Lengths

For lengths from 0 up to and including 12" (305 mm)

Tolerance: $\pm 1/8" \pm 3 \text{ mm}$

For lengths $\geq 12" (305 \text{ mm}) < 18" (457 \text{ mm})$

Tolerance: $\pm 3/16" \pm 5 \text{ mm}$

For lengths $\geq 18" (457 \text{ mm}) < 36" (914 \text{ mm})$

Tolerance: $\pm 1/4" \pm 6 \text{ mm}$

For lengths $\geq 36" (914 \text{ mm}) < 48" (1219 \text{ mm})$

Tolerance: $\pm 3/8" \pm 10 \text{ mm}$

For lengths $\geq 48" (1219 \text{ mm}) < 72" (1830 \text{ mm})$

Tolerance: $\pm 1/2" \pm 13 \text{ mm}$

For lengths $\geq 72" (1830 \text{ mm})$

Tolerance: $\pm 1\%$

Elbow angle and angle of orientation

Tolerance: ± 3

Angle Couplings

A - To measure angle of offset of a hose assembly, point one end of coupling "A" (the nearest) to a vertical position downward. The angle can then be measured from the centreline of this vertical coupling in an anticlockwise direction to the centreline of coupling "B" (the far coupling) (see illustration).

Relationships can then be expressed from 0° to 360°. If angle not given elbows are positioned at 0°.

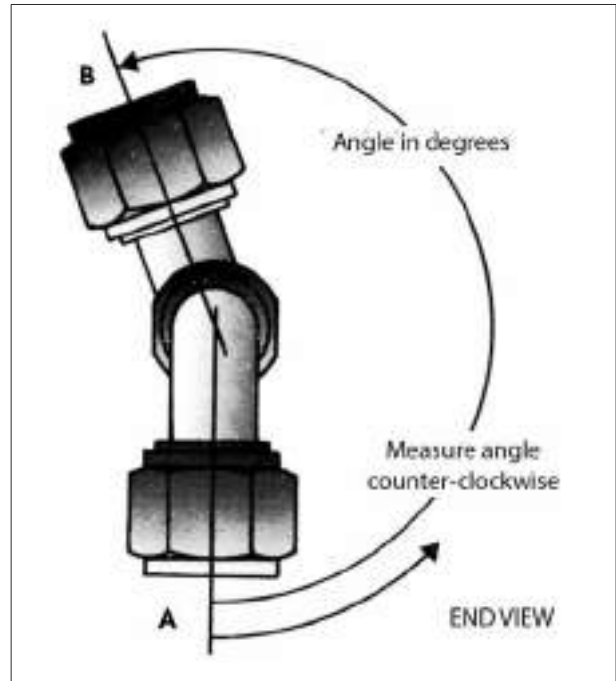

// FITTINGS GUIDELINES

FITTING IDENTIFICATION

Dash numbers

Most fluid piping system sizes are measured by dash numbers. These are universally used abbreviations for the size of component expressed as the numerator of the fraction with the denominator always being 16. For example, a -04 port is 4/16 or 1/4 inch. Dash numbers are usually nominal (in name only) and are abbreviations that make ordering of components easier.

There are many coupling systems used for hydraulic connections. They are identified as: **American, British, French, German, Japanese.**

This section lists the origin and coupling style. Descriptions and dimensional data follows each coupling style.

AMERICAN THREAD TYPES

NPTF (National Pipe Tapered Fuel)

This is a dryseal thread, the National pipe tapered thread for fuels. This is used for both male and female ends. This connection is still widely used in fluid power systems, even though it is not recommended by the National Fluid Power Association (N.F.P.A.) for use in hydraulic applications.

The NPTF male will mate with the NPTF, NPSF or NPSM female. The NPTF male has tapered threads and a 30° inverted seat. The NPTF female has tapered threads and no seat.

The seal takes place by deformation of the threads. The NPSM female has straight threads and a 30° inverted seat. The seal takes place on the 30° seat.

The NPTF connector is similar to, but not interchangeable with, the BSPT connector. The thread pitch is different in most sizes. Also, the thread angle is 60° instead of the 55° angle found on BSPT threads.

NPSF (National Pipe Straight Thread for Fuels)

The National pipe straight thread for fuels. This is sometimes used for female ends and properly mates with the NPTF male end. However, the SAE recommends the NPTF thread in preference to the NPSF for female ends.

NPSM (National Pipe Straight Mechanical)

National pipe straight thread for mechanical joint. This is used on the female swivel nut of iron pipe swivel adapters. The leak-resistant joint is not made by the sealing fit of threads, but by a tapered seat in the coupling end. This connection is sometimes used in fluid power systems.

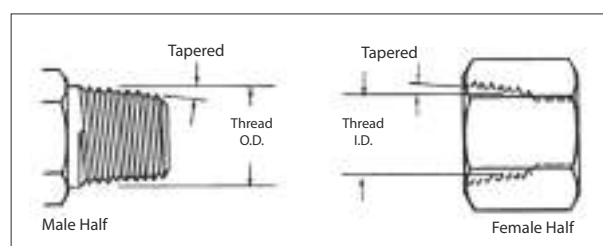

Thread Identification Table

National Pipe Straight Mechanical (NPSM)

National Pipe Tapered for Fuels (NPTF)

Dash	Tube Size	Thread Size	Female Thread I.D.		Male Thread O.D.	
	(in)	(in-TPI)	(mm)	(in)	(mm)	(in)
-2	1/8	1/8-27	8.7	0.34	10.3	0.41
-4	1/4	1/4-18	11.9	0.47	14.3	0.56
-6	3/8	3/8-18	15.1	0.59	17.5	0.69
-8	1/2	1/2-14	18.3	0.72	21.4	0.84
-12	3/4	3/4-14	23.8	0.94	27.0	1.06
-16	1	1-11.1/2	30.2	1.19	33.3	1.31
-20	1.1/4	11/4-11.1/2	38.9	1.53	42.9	1.69
-24	1.1/2	11/2-11.1/2	44.5	1.75	48.4	1.91
-32	2	2 - 11.1/2	57.2	2.25	60.3	2.38

SAE J514 Straight Thread O-Ring Boss (ORB)

This port connection is recommended by the N.F.P.A. for optional leakage control in medium and high pressure hydraulic systems. The O’ring boss male will mate with an O’ring boss female only.

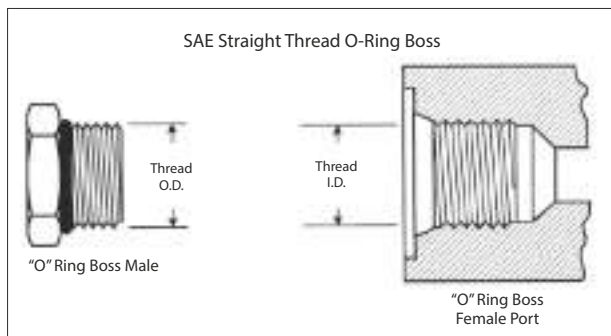

**Thread Identification Table
SAE J514 Straight Thread O-Ring Boss**

Dash	Tube Size	Thread Size	Female Thread I.D.		Male Thread O.D.	
	(in)	(in-TPI)	(mm)	(in)	(mm)	(in)
-2	1/8	5/16-24	6.9	0.27	7.8	0.31
-3	3/16	3/8-24	8.5	0.34	9.4	0.37
-4	1/4	7/16-20	9.9	0.39	11.2	0.44
-5	5/16	1/2-20	11.5	0.45	12.6	0.49
-6	3/8	9/16-18	12.9	0.51	14.1	0.56
-8	1/2	3/4-16	17.5	0.69	18.9	0.74
-10	5/8	7/8-14	20.5	0.81	22.1	0.87
-12	3/4	1.1/16-12	24.9	0.98	26.9	1.06
-14	7/8	1.3/16-12	28.1	1.11	30.3	1.18
-16	1	1.5/161/2	31.3	1.23	33.1	1.31
-20	1.1/4	1.5/8-12	39.2	1.54	41.1	1.62
-24	1.1/2	1.7/8-12	45.6	1.79	47.4	1.87
-32	2	2.1/2-12	61.4	2.42	63.3	2.49

The male has straight threads and an O’ring. The female has straight threads and a sealing face. The seal is made at the O’ring on the male and the sealing face on the female. The threads hold the connection mechanically.

SAE J514 37° (JIC)

The Society of Automotive Engineers (SAE) specifies a 37° angle flare or seat be used with high pressure hydraulic tubing. These are commonly called JIC couplings. The JIC 37° flare male will mate with a JIC female only. The JIC male has straight threads and a 37° flare seat. The JIC female has straight threads and a 37° flare seat. The seal is made on the 37° flare seat by establishing a line contact between the male flare and the female cone seat. The threads hold the connection mechanically.

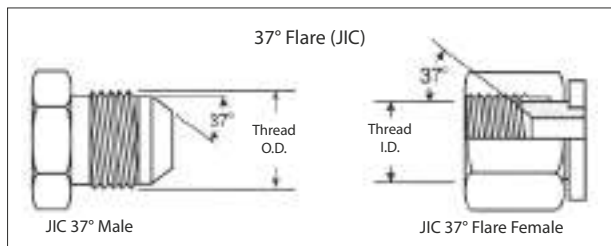

**Thread Identification Table
SAE J514 37° Flare (JIC)**

Dash	Tube Size	Thread Size	Female Thread I.D.		Male Thread O.D.	
	(in)	(in-TPI)	(mm)	(in)	(mm)	(in)
-2	1/8	5/16-24	6.9	0.27	7.8	0.31
-3	3/16	3/8-24	8.5	0.34	9.4	0.37
-4	1/4	7/16-20	9.9	0.39	11.2	0.44
-5	5/16	1/2-20	11.5	0.45	12.6	0.49
-6	3/8	9/16-18	12.9	0.51	14.1	0.56
-8	1/2	3/4-16	17.5	0.69	18.9	0.74
-10	5/8	7/8-14	20.5	0.81	22.1	0.87
-12	3/4	1.1/16-12	24.9	0.98	26.9	1.06
-14	7/8	1.3/16-12	28.1	1.11	30.3	1.18
-16	1	1.5/16-12	31.3	1.23	33.1	1.31
-20	1.1/4	1.5/8-12	39.2	1.54	41.1	1.62
-24	1.1/2	1.7/8-12	45.6	1.79	47.4	1.87
-32	2	2.1/2-12	61.4	2.42	63.3	2.49

CAUTION: In the -02, -03, -04, -05, -08 and -10 sizes, the threads of the SAE 45° flare and the SAE 37° flare are the same. However, the sealing surface angles are not the same. Carefully measure the seat angle to differentiate.

SAE J512 45°

A term usually applied to fittings having a 45° angle flare or seat. Soft copper tubing is generally used in such applications as it is easily flared to the 45° angle. These are for low pressure applications - commonly used in refrigeration, automotive and truck piping systems. The SAE 45° flare male will mate with an SAE 45° flare female only.

The SAE male has straight threads and a 45° flare seat.

The SAE female has straight threads and a 45° flare seat.

The seal is made on the 45° flare seat.

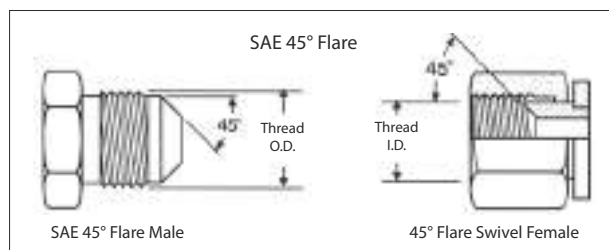

Thread Identification Table

SAE J512 45°

Dash	Tube Size	Thread Size	Female Thread I.D.		Male Thread O.D.	
	(in)	(in-TPI)	(mm)	(in)	(mm)	(in)
-2	1/8	5/16-24	6.9	0.27	7.9	0.31
-3	3/16	3/8-24	8.6	0.34	9.6	0.38
-4	1/4	7/16-20	9.9	0.39	11.2	0.44
-5	5/16	1/2-20	11.4	0.45	12.7	0.50
-6	3/8	5/8-18	14.2	0.56	15.7	0.62
-7	7/16	11/16-16	15.7	0.62	17.3	0.68
-8	1/2	3/4-16	17.0	0.68	19.0	0.75
-10	5/8	7/8-14	20.3	0.80	22.3	0.88
-12	3/4	1.1/16-14	25.1	0.99	26.9	1.06
-14	7/8	1.1/4-12	29.5	1.16	31.7	1.25
-16	1	1.3/8-12	32.5	1.28	35.0	1.38

The threads hold the connection mechanically. CAUTION: In the -02, -03, -04, -05, -08 and -10 sizes, the threads of the SAE 45° flare and the SAE 37° flare are the same. However, the sealing surface angles are not the same. Carefully measure the seat angle to differentiate.

SAE J1453 O-Ring Face Seal (ORFS)

A seal is made when the O-ring in the male contacts the flat face on the female. Couplings are intended for hydraulic systems where elastomeric seals are acceptable to overcome leakage and leak resistance is crucial. This connection offers the very best leakage control available today.

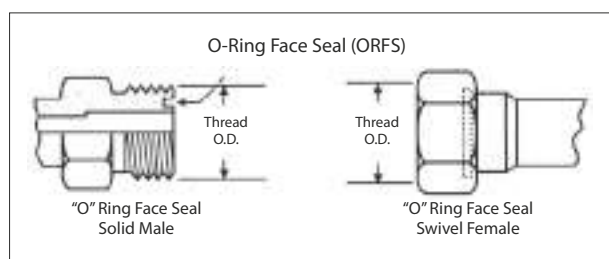

Thread Identification Table

SAE J1453 O-Ring Face Seal (ORFS)

Dash	Tube Size	Thread Size	Female Thread I.D.		Male Thread O.D.	
	(in)	(in-TPI)	(mm)	(in)	(mm)	(in)
-4	1/4	9/16-18	12.9	0.51	14.1	0.56
-6	3/8	11/16-16	15.9	0.63	17.3	0.68
-8	1/2	13/16-16	19.1	0.75	20.5	0.81
-10	5/8	1-14	23.6	0.93	25.2	0.99
-12	3/4	1.3/16-12	28.1	1.11	30.0	1.18
-16	1	1.7/16-12	34.4	1.36	36.3	1.43
-20	1.1/4	1.11/16-12	40.8	1.61	42.7	1.68
-24	1.1/2	2-12	48.7	1.92	50.6	1.99

The male connector has a straight thread and a machined flat face. The female has a straight thread and a machined flat face. The seal takes place by compressing the O-Ring onto the flat face of the female, similar to the split flange type fitting. The threads hold the connection mechanically.

SAE J512 Inverted Flare

This connection is frequently used in automotive systems. The male connector can either be a 45° flare in the tube fitting form or a 42° seat in the machined adapter form. The female has a straight thread with a 42° inverted flare. The seal takes place on the flared surface. The threads hold the connection mechanically

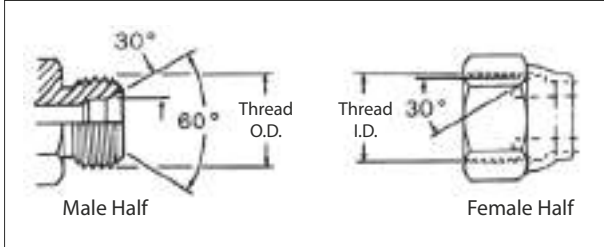

**Thread Identification Table
SAE J512 Inverted Flare**

Dash	Tube Size	Thread Size	Female Thread I.D.		Male Thread O.D.	
	(in)	(in-TPI)	(mm)	(in)	(mm)	(in)
-2	1/8	5/16-28	6.9	0.27	7.9	0.31
-3	3/16	3/8-24	8.6	0.34	9.6	0.38
-4	1/4	7/16-24	9.9	0.39	11.2	0.44
-5	5/16	1/2-20	11.4	0.45	12.7	0.50
-6	3/8	5/8-18	14.2	0.56	15.7	0.62
-7	7/16	11/16-18	15.7	0.62	17.3	0.68
-8	1/2	3/4-18	17.0	0.68	19.0	0.75
-10	5/8	7/8-18	20.3	0.80	22.3	0.88
-12	3/4	1.1/16-16	25.1	0.99	26.9	1.06

SAE J1467 Clip Fastener

This is a radial O-Ring seal connection commonly used for hydraulic applications in underground mines. The male contains an exterior O-Ring and backup ring, plus a groove to accept the "staple". The female has a smooth bore with two holes for the staple.

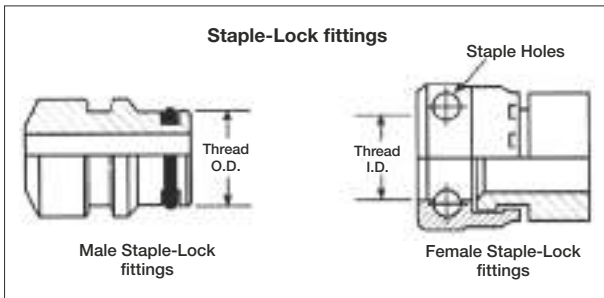

**Thread Identification Table
SAE J1467 Clip Fastener**

Dash Size	Inch Size	Female Staple-Lock I.D.		Male Staple-Lock O.D.	
	(in)	(mm)	(in)	(mm)	(in)
-4	1/4	14.9	19/32	15.1	19/32
-6	3/8	19.9	51/64	20.1	51/64
-8	1/2	23.9	61/64	24.1	61/64
-12	3/4	28.9	1.9/64	29.1	1.9/64
-16	1	38.9	1.35/64	39.1	1.35/64
-20	1.1/4	45.9	1.13/16	46.1	1.13/16
-24	1.1/2	54.9	1.11/64	55.2	2.11/64
-32	2	63.9	1.17/32	64.2	2.17/32

A "U" shaped retaining clip or staple is inserted through the two holes, passing through the groove in the male to lock the connection together. The seal takes place by contact between the O-Ring in the male and the smooth bore of the female.

SAE J518/ISO - DIS 6162/JIS B8363 O-Ring Flange

This connection is commonly used in fluid power system. There are two pressure ratings. Code 61 Form R, PN 35/350 bar, Type I, is referred to as the “standard” series and Code 62 Form S, PN 415 bar, Type II, is the “heavy duty” “6000 psi” series. The design concept for both series is the same, but the bolt hole spacing and flanged head diameters are larger for the higher pressure, Code 62 connection.

The female (port) is an unthreaded hole with four bolt holes in a rectangular pattern around the port.

The male consists of a flanged head, grooved for an O-Ring, and either a captive flange or split flange halves with bolt holes to match the port. The seal take place on the O-Ring, which is compressed between the flange head and the flat surface surrounding the port. The threaded bolts hold the connection together.

SAE J518, DIN 20066, ISO/DIS 6162 and JIS B 8363 are interchangeable, except for bolt sizes.

*All Code 61 flange head hose couplings meet or exceed SAE J518 Code 61 requirements for hydraulic split flange connections. The Code 61 flange head design can withstand a maximum operating pressure of 3000 to 5000 psi depending on size.

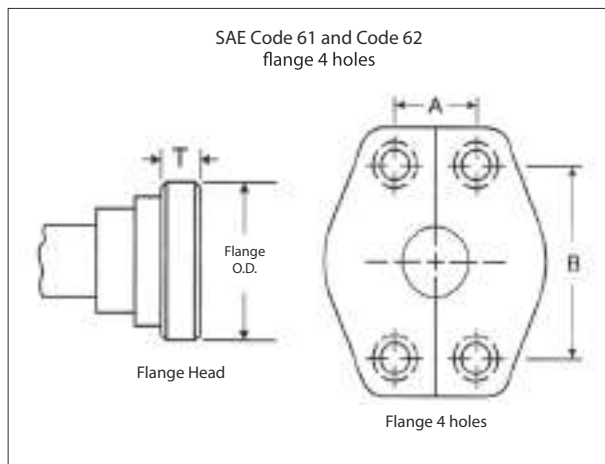

Flange Dash	SAE Cod 61 FORM R - PN 35/350 - TYPE I								SAE Cod 62 FORM S - PN 415 - TYPE II								CATERPILLAR								
	Flange Head Size		Flange Head T		A		B		Flange Head Size		Flange Head T		A		B		Flange Head Size		Flange Head T		A		B		
Size	(in)	(mm)	(in)	(mm)	(in)	(mm)	(in)	(mm)	(in)	(mm)	(in)	(mm)	(in)	(mm)	(in)	(mm)	(in)	(mm)	(in)	(mm)	(in)	(mm)	(in)	(mm)	
-8	1.19	30.2	.265	6.7	.69	17.5	1.50	38.1	1.25	31.8	.305		.71	18.2	1.59	40.5									
-10*	1.34	34.0	.265	6.7	.78	19.8	1.69	42.9																	
-12	1.50	38.1	.265	6.7	.87	22.2	1.89	47.6	1.63	41.3	.345	8.7	.94	23.8	2.00	50.8	1.63	41.3	.56	14.2	.94	23.8	2.00	50.8	
-16	1.75	44.5	.315	8.0	1.03	26.2	2.05	52.4	1.88	47.6	.375	9.5	1.10	27.8	2.25	57.2	1.88	47.6	.56	14.2	1.10	27.8	2.25	57.2	
-20	2.00	50.8	.315	8.0	1.19	30.2	2.31	58.7	2.13	54.0	.405	10.3	1.26	31.8	2.63	66.7	2.13	54.0	.56	14.2	1.26	31.8	2.63	66.7	
-24	2.38	60.3	.315	8.0	1.41	35.7	2.75	69.9	2.50	63.5	.495	12.6	1.44	36.6	3.13	79.4	2.50	63.5	.56	14.2	1.44	36.6	3.13	79.4	
-32	2.81	71.4	.375	9.5	1.69	42.9	3.06	77.8	3.13	79.4	.495	12.6	1.73	44.4	3.81	96.8	3.13	79.4	.56	14.2	1.73	44.4	3.81	96.8	
-40	3.31	84.1	.375	9.5	2.00	50.8	3.50	88.9																	

T = Thickness
 -10 is a non SAE size flange

How to measure

Four Bolt Flange - First measure the port hole diameter using the caliper. Next, measure the longest bolt hole spacing from centre-to-centre (Dimension “A”) or measure the flanged head diameter. O.D.

1. The size -10, which is common outside of North America is not an SAE Standard size.
2. Caterpillar flanges, which are the same flange O.D. as SAE Code 62, have a thicker flange head.
3. Poclain flanges, which are completely different from SAE flanges.

BRITISH CONNECTIONS

British Standard Pipe Parallel (BSPP)

This connection is frequently used in automotive systems. The male connector can either be a 45° flare in the tube fitting form or a 42° seat in the machined adapter form. The female has a straight thread with a 42° inverted flare. The seal takes place on the flared surface. The threads hold the connection mechanically.

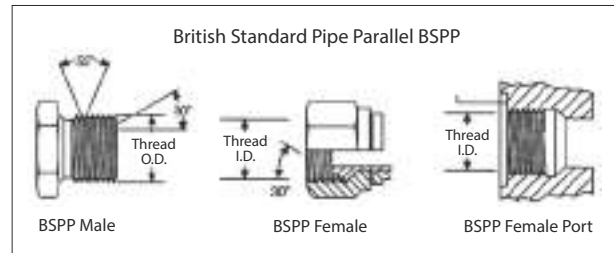

British Standard Pipe Tapered (BSPT)

The BSPT (tapered) male will mate with a BSPT (tapered) female, or a BSPP (parallel) female. The BSPT male has tapered threads. When mating with either the BSPT (tapered) female or the BSPP (parallel) female port, the seal is made on the threads accomplished by thread distortion. A thread sealant is recommended.

The BSPT connector is similar to, but not interchangeable with, the NPTF connector. The thread pitch is different in most cases, and the thread angle is 55° instead of the 60° angle found on NPTF threads.

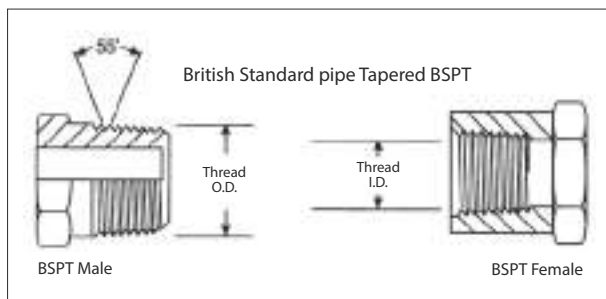

Thread Identification Table

BSPP - (British Standard Pipe Parallel)

BSPT - (British Standard Pipe Tapered)

Dash Size	Inch Size	Thread Size	Female Thread I.D.		Male Thread O.D.	
			(mm)	(in)	(mm)	(in)
-2	1/8	1/8-27	8.7	0.34	9.5	0.38
-4	1/4	1/4-18	11.1	0.44	13.5	0.56
-6	3/8	3/8-18	15.1	0.59	16.7	0.66
-8	1/2	1/2-14	18.3	0.72	20.6	0.81
-10	5/8	5/8-14	20.6	0.81	23.0	0.91
-12	3/4	3/4-14	23.8	0.94	26.2	1.03
-16	1	1-11	30.2	1.19	33.3	1.31
-20	1-1/4	1.1/4-11	38.9	1.53	41.1	1.66
-24	1-1/2	1.1/2-11	45.2	1.78	47.6	1.88
-32	2	2-11	56.4	2.22	59.5	2.34

FRENCH CONNECTIONS

French GAZ have a 24° seat and metric threads. These are similar to German DIN couplings, but the threads are different in some sizes, the French use fine threads in all sizes. French flanges are different than SAE, they have a lip that protrudes from the flange face. These are Poclairn style flanges.

Millimetrique and GAZ 24°

This connection consists of a common male and two different females. The French Metric (GAZ) male will mate with the female 24° cone or the female tube fitting. The male has a 24° seat and straight metric threads. The female has a 24° seat or a tubing sleeve and straight metric threads. The Millimetrique Series is used with whole number metric O.D. tubing and the GAZ Series is used with fractional number metric O.D. pipe size tubing.

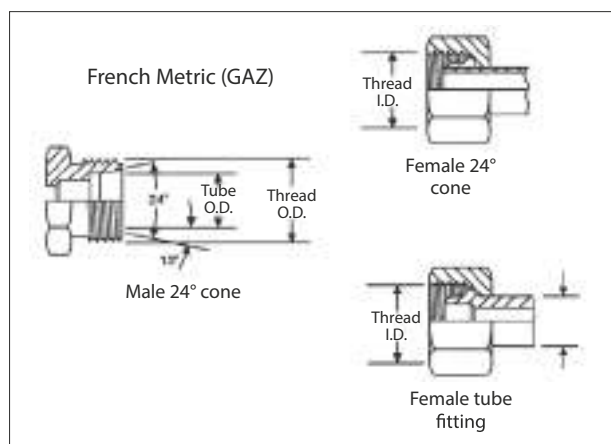

Thread Identification Table French Metric Millimetrique

Metric Thread (dia x pitch)	Female Thread I.D.		Male Thread O.D.		Tube O.D.	
	(mm)	(in)	(mm)	(in)	(mm)	(in)
M12 X 1.0	11.0	0.43	12.0	0.47	6	0.24
M14 X 1.5	12.5	0.49	14.0	0.55	8	0.31
M16 X 1.5	14.5	0.57	16.0	0.63	10	0.39
M18 X 1.5	16.5	0.65	18.0	0.71	12	0.47
M20 X 1.5	18.5	0.73	20.0	0.79	14	0.55
M22 X 1.5	20.5	0.81	22.0	0.87	15	0.59
M24 X 1.5	22.5	0.89	24.0	0.94	16	0.63
M27 X 1.5	25.5	1.00	27.0	1.06	18	0.71
M30 X 1.5	28.5	1.12	30.0	1.18	22	0.87
M33 X 1.5	31.5	1.24	33.0	1.30	25	0.98
M36 X 1.5	34.5	1.36	36.0	1.42	28	1.10
M39 X 1.5	37.5	1.48	39.0	1.54	30	1.18
M42 X 1.5	40.5	1.59	42.0	1.65	32	1.26
M45 X 1.5	43.5	1.71	45.0	1.77	35	1.38
M48 X 1.5	46.5	1.83	48.0	1.89	38	1.50
M52 X 1.5	50.5	1.99	52.0	2.05	40	1.57
M54 X 2.0	51.9	2.04	54.0	2.13	45	1.77

Thread Identification Table French Metric GAZ 24° Cone

Dash Size (dash)	Metric Thread (dia x pitch)	Female Thread I.D.		Male Thread O.D.		Tube O.D.	
		(mm)	(in)	(mm)	(in)	(mm)	(in)
-6	M20 X 1.5	18.5	0.73	20.0	0.78	13.25	0.52
-8	M24 X 1.5	22.5	0.89	24.0	0.94	16.75	0.66
-10	M30 X 1.5	28.5	1.12	30.0	1.18	21.25	0.83
-12	M36 X 1.5	34.5	1.36	36.0	1.41	26.75	1.05
-16	M45 X 1.5	43.5	1.71	45.0	1.77	33.50	1.32
-20	M52 X 1.5	50.5	1.99	52.0	2.04	42.25	1.66

GAZ Poclairn 24° Flange

The Poclairn (French GAZ) 24° high pressure flange is usually found on Poclairn equipment. The male flange will mate with a female flange or a port. The seal is made on the 24° seat.

Nominal Size (in)	A		B		E	
	(mm)	(in)	(mm)	(in)	(mm)	(in)
1/2	39.9	1.57	18.3	.72	14	.55
5/8	39.9	1.57	18.3	.72	14	.55
3/4	50.8	2	23.9	.94	18	.71

GERMAN DIN CONNECTIONS

A coupling referred to as metric, usually means a DIN coupling. Flanges are standard Code 61 or Code 62.

DIN 2353 24° Cone

The DIN 24° cone male will mate with any of the three females shown below.

The male has a 24° seat, straight metric threads, and a recessed counterbore which matches the tube O.D. used with it. The mating female may be a 24° cone with O’ring, (DKO type) a metric tube fitting or a universal 24° or 60° cone.

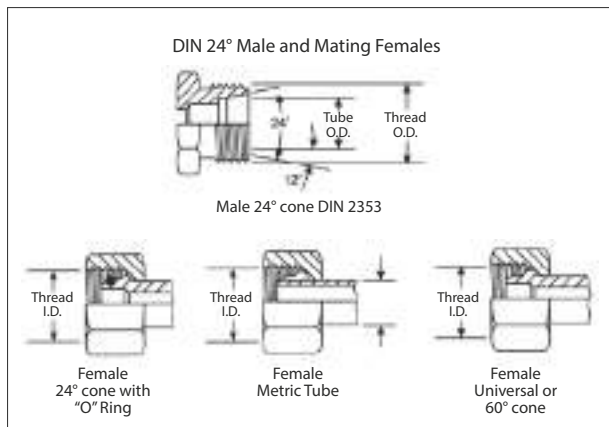

Thread Identification Table

DIN 24° Cone

Metric Thread (dia x pitch)	Female Thread I.D.		Male Thread O.D.		Tube O.D.			
	(mm)	(in)	(mm)	(in)	Light Series		Heavy Series	
					(mm)	(in)	(mm)	(in)
M12 X 1.5	10.5	0.41	12	0.47	6	0.24		
M14 X 1.5	12.5	0.49	14	0.55	8	0.31	6	0.24
M16 X 1.5	14.5	0.57	16	0.63	10	0.39	8	0.31
M18 X 1.5	16.5	0.65	18	0.71	12	0.47	10	0.39
M20 X 1.5	18.5	0.73	20	0.79			12	0.47
M22 X 1.5	20.5	0.81	22	0.87	15	0.59	14	0.55
M24 X 1.5	22.5	0.89	24	0.94			16	0.63
M26 X 1.5	24.5	0.96	26	1.02	18	0.71		
M30 X 2.0	27.9	1.10	30	1.18	22	0.87	20	0.79
M36 X 2.0	33.9	1.33	36	1.42	28	1.10	25	0.98
M42 X 2.0	39.9	1.57	42	1.65			30	1.18
M45 X 2.0	42.9	1.69	45	1.77	35	1.38		
M52 X 2.0	49.9	1.96	52	2.05	42	1.65	38	1.50

There is a light and heavy series DIN coupling. Proper identification is made by measuring both the thread size and the tube O.D. (The heavy series has a smaller tube O.D. than the light, but has a thicker wall section).

DIN 3863 60° Cone

This connection is frequently used in hydraulic systems. The DIN 60° cone male will mate with the female universal 24° or 60° cone only.

The male has a 60° seat and straight metric threads. The female has a 24° and 60° universal seat and straight metric threads. The seal takes place by contact between the cone of the male and the nose of the flareless swivel. The threads hold the connection mechanically.

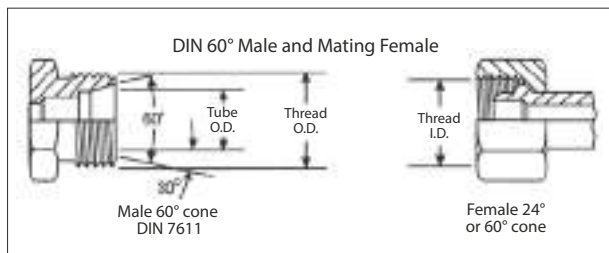

Thread Identification Table

DIN 60°

Metric Thread (dia x pitch)	Female Thread I.D.		Male Thread O.D.		Tube O.D.	
	(mm)	(in)	(mm)	(in)	(mm)	(in)
M12 X 1.5	10.5	0.41	12	0.47	6	0.24
M14 X 1.5	12.5	0.49	14	0.55	8	0.31
M16 X 1.5	14.5	0.57	16	0.63	10	0.39
M18 X 1.5	16.5	0.65	18	0.71	12	0.47
M22 X 1.5	20.5	0.81	22	0.87	15	0.59
M26 X 1.5	24.5	0.96	26	1.02	18	0.71
M30 X 1.5	28.5	1.12	30	1.18	22	0.87
M38 X 1.5	36.5	1.44	38	1.50	28	1.10
M45 X 1.5	43.5	1.71	45	1.77	35	1.38
M52 X 1.5	50.5	1.99	52	2.05	42	1.65

Metric Standpipe

A metric standpipe is comprised of three components attached to a male fitting. The components are a Standpipe, Bite Sleeve and Metric Nut. The nut is placed over the Standpipe, followed by the Bite Sleeve (see illustration below). For DIN light assemblies, a DIN light metric nut is used. For DIN heavy assemblies, a DIN heavy metric nut is used. Bite Sleeve and Standpipe are selected on the basis of tube O.D.

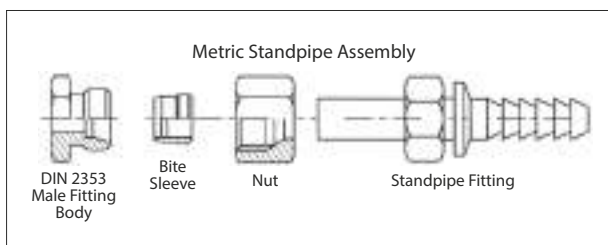

Tube O.D. (mm)	Metric Nut Thread	
	Light	Heavy
6	M12 x 1.5	
8	M14 x 1.5	M16 x 1.5
10	M16 x 1.5	M18 x 1.5
12	M18 x 1.5	M20 x 1.5
15	M22 x 1.5	
16		M24 x 1.5
18	M26 x 1.5	
20		M30 x 2.0
22	M30 x 1.5	
25		M36 x 2.0
28	M36 x 2.0	
30		M42 x 2.0
35	M45 x 2.0	
38		M52 x 2.0
42	M52 x 2.0	

JAPANESE CONNECTIONS

Japanese equipment uses JIS (Japanese Industrial Standard) couplings with a 30° seat and British Standard Pipe Parallel threads. All flanges are Code 61 or Code 62 (except -10).

JIS 30° Flare Parallel Pipe Threads - JIS B 0202

These Japanese 30° flare male coupling will mate with a Japanese 30° flare female only. The male and female have straight threads and a 30° seat. The seal is made on the 30° seat. The threads on the Japanese 30° flare connector conform to JIS B 0202, the same as the BSPP threads. Both the British and Japanese connectors have a 30° seat, but they are not interchangeable, because the British seat is inverted.

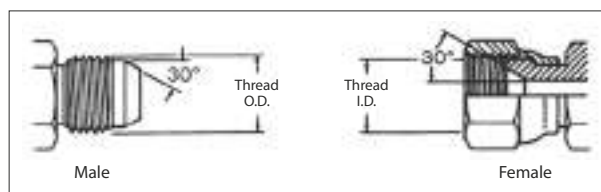

JIS 30° Inverted Seat, Parallel Pipe Threads - JIS B 0202

The JIS parallel is similar to the BSPP connection. The JIS parallel thread and the BSPP connection are interchangeable.

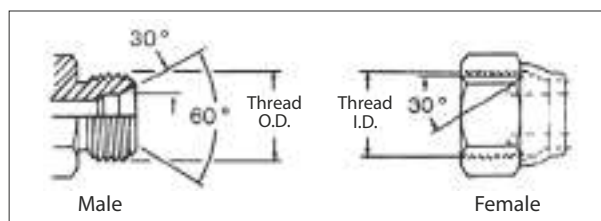

JIS Tapered Pipe Thread (PT) - JIS B 0203

The JIS tapered pipe thread connection is similar to the BSPT connection and fully interchangeable. The Japanese connection does not have a 30° Flare, and will not mate with the BSPP female. The thread conforms to JIS B 0203, same as BSPT threads. The seal on the JIS tapered pipe thread connection is made on the threads.

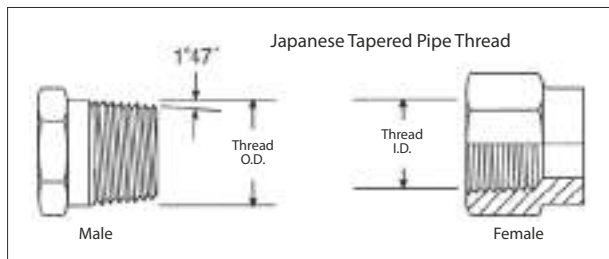

Thread Identification Table

Dash Size	Inch Size	Thread Size (in-TPI)	Female Thread I.D.		Male Thread O.D.	
			(mm)	(in)	(mm)	(in)
-2	1/8	1/8-27	8.7	0.34	9.5	0.38
-4	1/4	1/4-18	11.1	0.44	13.5	0.56
-6	3/8	3/8-18	15.1	0.59	16.7	0.66
-8	1/2	1/2-14	18.3	0.72	20.6	0.81
-10	5/8	5/8-14	20.6	0.81	23.0	0.91
-12	3/4	3/4-14	23.8	0.94	26.2	1.03
-16	1	1-11	30.2	1.19	33.3	1.31
-20	1-1/4	1.1/4-11	38.9	1.53	41.1	1.66
-24	1-1/2	1.1/2-11	45.2	1.78	47.6	1.88
-32	2	2-11	56.4	2.22	59.5	2.34

Komatsu Style 30° Flare Parallel Threads

The Komatsu style 30° Flare Parallel thread coupling is identical to the Japanese 30° Flare parallel except for the threads. The Komatsu uses Metric fine threads which conform to JIS B 0207. The Komatsu connector seals on the 30° Flare.

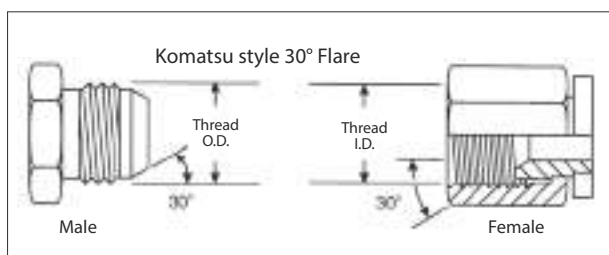

Dash Size	Inch Size	Metric Thread Size	Male Thread O.D.	B Thread I.D.
			(mm)	(mm)
-6	3/8	M18x1.5	18	16.4
-8	1/2	M22x1.5	22	20.4
-10	5/8	M24x1.5	24	22.4
-12	3/4	M30x1.5	30	28.4
-16	1	M33x1.5	33	31.4
-20	1-1/4	M36x1.5	36	34.4
-24	1-1/2	M42x1.5	42	40.4

Komatsu Flange Fitting

The Komatsu Flange fitting is nearly identical to and fully interchangeable with the SAE Code 61 flange fitting. In all sizes the O-ring dimensions are different. When replacing a Komatsu flange with an SAE style flange, an SAE style O-ring must be used.

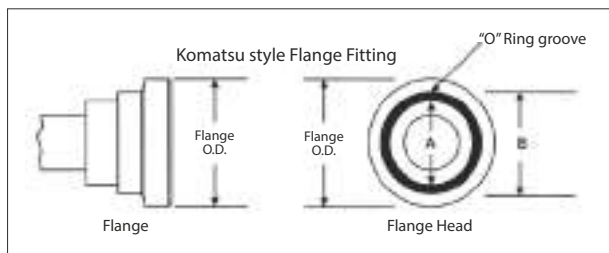

Flange Dash Size	Flange Size (In)	A	B
-8	1.19	.73	.98
-10*	1.34	.73	1.10
-12	1.50	.85	1.22
-16	1.75	1.12	1.50
-20	2.00	1.36	1.73
-24	2.38	1.75	2.12
-32	2.81	2.22	2.56

*is a non SAE size flange

RACOMMENDED FITTING AND ADAPTER INSTALLATION TORQUE

SAE J514 37° CONE (JIC)

Dash	Thread	Lb.ft		N.m	
		Min	Max	Min	Max
-4	7/16-20	11	12	15	16
-5	1/2-20	14	15	19	21
-6	9/16-18	18	20	24	28
-8	3/4-16	36	39	49	53
-10	7/8-14	57	63	77	85
-12	1 1/16-12	79	88	107	119
-14	1 3/16-12	94	103	127	140
-16	1 5/8-12	108	113	147	154
-20	1 5/8-12	127	133	172	181
-24	1 7/8-12	158	167	215	226
-32	2 1/2-12	245	258	332	350

BSPP without O-Ring

Dash	Thread	Lb.ft	N.m
-2	1/8-28	7	10
-4	1/4-19	15	20
-6	3/8-19	26	35
-8	1/2-14	44	60
-10	5/8-14	52	70
-12	3/4-14	85	115
-16	1-11	103	140
-20	1 1/4-11	155	210
-24	1 1/2-11	214	290
-32	2-11	295	400

SAE J1453 O-Ring Face Seal (ORFS)

Dash	Thread	Lb.ft		N.m	
		Min	Max	Min	Max
-4	9/16-18	18	21	25	28
-6	11/16-16	30	32	40	44
-8	13/16-16	41	44	55	60
-10	1-14	46	50	60	68
-12	1 3/16-12	65	70	90	95
-16	1 7/16-12	92	100	125	135
-20	1 11/16-12	125	140	170	190
-24	2-12	150	165	200	225

BSPP with O-Ring

Dash	Thread	Lb.ft	N.m
-2	1/8-28	N/A	N/A
-4	1/4-19	15	20
-6	3/8-19	26	35
-8	1/2-14	37	50
-10	5/8-14	44	60
-12	3/4-14	63	85
-16	1-11	85	115
-20	1 1/4-11	140	190
-24	1 1/2-11	177	240
-32	2-11	221	300

SAE Flange J518 Code 61

Dash	Thread	Lb.ft		N.m	
		Min	Max	Min	Max
-8	1/2	15	19	20	25
-12	3/4	21	29	28	40
-16	1	27	35	37	48
-20	1 1/4	35	46	48	62
-24	1 1/2	46	58	62	79
-32	2	54	66	73	90
-40	2 1/2	79	91	107	124
-48	3	137	149	186	203

JIS (B8363)

Dash	Thread	Lb.ft	N.m
-4	1/4-19	19	25
-6	3/8-19	25	34
-8	1/2-14	49	64
-10	5/8-14	100	132
-12	3/4-14	100	132
-16	1-11	149	196
-20	1 1/4-11	171	225
-24	1 1/2-11	194	255
-32	2-11	240	316

SAE J518 Code 62

Dash	Thread	Lb.ft		N.m	
		Min	Max	Min	Max
-8	1/2	15	19	20	25
-12	3/4	25	33	34	45
-16	1	42	50	56	68
-20	1 1/4	63	75	85	102
-24	1 1/2	117	133	158	181
-32**	2	200	217	271	294

Metric

Thread	Lb.ft		N.m	
	Min	Max	Min	Max
M12x1,5	8	11	15	20
M14x1,5	13	18	25	30
M16x1,5	19	26	35	40
M18x1,5	22	30	40	45
M20x1,5	24	33	45	50
M22x1,5	32	44	60	70
M24x1,5	41	55	75	85
M26x1,5	46	63	85	95
M30x2	57	77	105	120
M36x2	74	100	135	150
M42x2	111	151	205	230
M45x2	136	184	250	280
M52x2	147	199	270	300

JIC FFFT TORQUE METHOD

The FFFT (Flats From Finger Tight) method allows to assemble fittings and adapters at the correct torque value without a dynamometric wrench. The rotation applied according the value shown in tab.1 ensures a good sealing, avoid unscrewing and over torque that can cause nut or cone crack.

Assembling instruction:

- hand tighten the joint
- make a longitudinal mark on one of the flats of hex and continue it on the body hex as shown in Fig.1
- tighten the joint further by the number of flat as shown in Tab.1

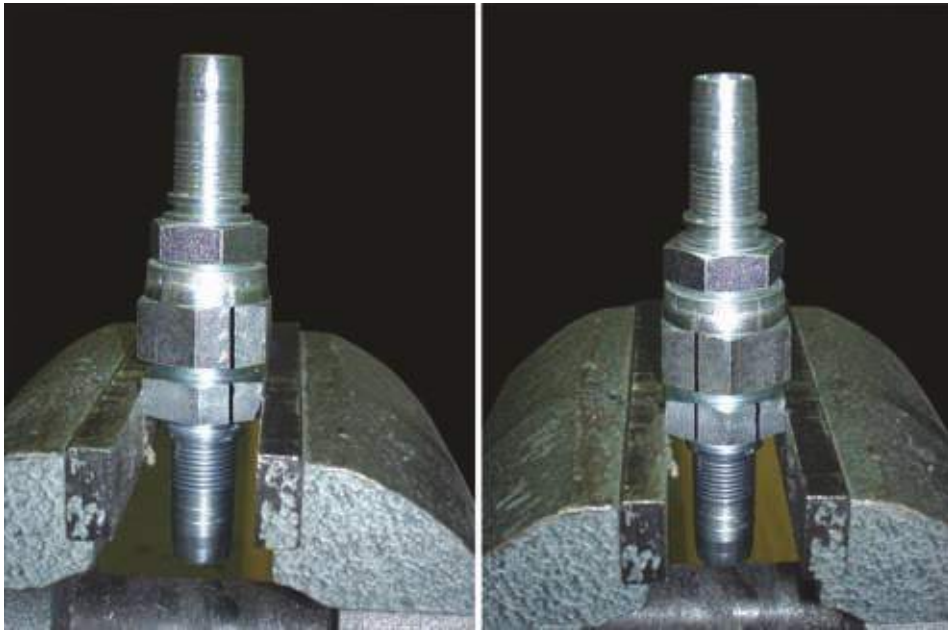

Fig. 1

Assembling value - carbon steel material - SAE J514 JIC 37° flare						
Dash size	Thread	Lb*ft		N*m		FFFT
		min	max	min	max	
-4	7/16-20	11	12	15	16	2
-5	1/2-20	14	15	19	21	2
-6	9/16-18	18	20	24	28	2
-8	3/4-16	36	39	49	53	1.5
-10	7/8-14	57	63	77	85	1.5
-12	1 1/16-12	79	88	107	119	1
-14	1 3/16-12	94	103	127	140	1
-16	1 5/16-12	108	113	147	154	1
-20	1 5/8-12	127	133	172	181	1
-24	1 7/8-12	158	167	215	226	1
-32	2 1/2-12	245	258	332	350	1

Tab. 1

HOW TO DETERMINE THE THREAD TYPE USING CALLIPERS

By measuring with a caliper the outside diameter of the thread of a male or the inside diameter of the thread of a female you will get a measure in mm. By finding this value in mm on the below table, you'll be able to find the relevant thread type.

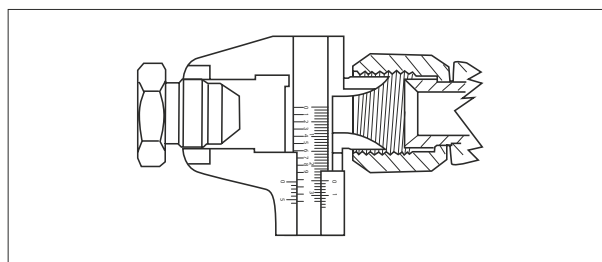

Male OD	mm	Female ID
	8,7	G1/8" BSP
1/8" – 27 NPTF	9,5	
G1/8" BSP	9,6	
M 10 x 1	9,8	
	9,9	7/16" – 20 JIC
	10,5	M 12 x 1,5
7/16" – 20 JIC	11,0	
	11,4	1/2" – 20 SAE
	11,6	G1/4" BSP
M 12 x 1,5	11,9	
1/4" – 18 NPTF	12,5	
	12,5	M 14 x 1,5
1/2" – 20 SAE	12,6	
	12,9	9/16" – 18 JIC
G1/4" BSP	13,0	
M 14 x 1,5	13,9	
9/16" – 18 JIC	14,2	
	14,5	M16 x 1,5
	15,1	G3/8" BSP
M 16 x 1,5	15,8	
3/8" – 18 NPTF	15,9	
	16,5	M18 x 1,5
G3/8" BSP	16,6	
	17,5	3/4" – 16 JIC
M 18 x 1,5	17,9	
	18,4	20 x 1,5 DKF
3/4" – 16 JIC	18,8	
	18,8	G1/2" BSP
1/2" – 14 NPT	19,8	
20 x 1,5 CEF	19,9	
	20,4	7/8" – 14 SAE
	20,5	M 22 x 1,5
G1/2" BSP	20,8	
	20,9	G5/8" BSP
M 22 x 1,5	21,9	
7/8" – 14 SAE	22,1	
	22,5	24 x 1,5 DKF
G5/8" BSP	22,8	
24 x 1,5 CEF	23,9	
	24,5	G3/4" BSP
	24,8	1 1/16" – 12 JIC
3/4" – 14 NPTF	25,1	
	25,5	M26 x 1,5
M 26 x 1,5	25,9	
G3/4" BSP	26,3	
1 1/16" – 12 JIC	26,8	

Male OD	mm	Female ID
	27,9	1 3/16" – 12 JIC
	28,0	M 30 x 2
	28,5	30 x 1,5 DKF
M 30 x2	29,8	
30 x 1,5 CEF	29,9	
1 3/16" – 12 JIC	30,1	
	30,7	G1" BSP
	31,2	1 5/16" – 12 JIC
1" – 11 1/2 NPTF	31,4	
	31,5	M 33 x 1,5
G1" BSP	33,1	
1 5/16" – 12 JIC	33,2	
	34,0	M 36 x 2
	34,5	36 x 1,5 DKF
M 36 x 2	35,8	
36 x 1,5 CEF	35,9	
	36,5	M 36 x 1,5
M 38 x 1,5	37,9	
	38,8	1 5/8" – 12 JIC
	39,4	G1 1/4" BSP
	39,8	M 42 x 1,5
1 1/4"–11 1/2 NPTF	40,2	
	40,5	M 42 x 1,5
1 5/8" – 12 JIC	41,1	
1 1/4" – 11 BSP	41,7	
M 42 x2	41,8	
	42,4	M 45 x 2
	43,3	45 x 1,5 DKF
M 45 x2	44,8	
45 x 1,5 CEF	44,9	
	45,1	1 7/8" – 12 JIC
	45,2	G1 1/2" BSP
1 1/2"–11 1/2 NPTF	46,3	
1 7/8" – 12 JIC	47,5	
G1 1/2" BSP	47,7	
	49,6	M 52 x 2
	50,3	52 x 1,5 DKF
M 52 x2	51,8	
52 x 1,5 CEF	51,9	
	57,4	G2" BSP
2" – 11 1/2 NPTF	58,3	
G2" BSP	59,4	
	61,1	2 1/2" – 12 JIC
	62,5	M 65 x 2
2 1/2" – 12 JIC	63,3	

PRESSURE CONVERSION TABLES

Metric to psi (1 KPa = .145 psi)

Kilo Pascal (KPa)	Mega Pascal (KPa)	Bar (Bar)	Pounds per Square Inch (psi)
100	0,1	1	14,5
200	0,2	2	29,0
300	0,3	3	43,5
400	0,4	4	58,0
500	0,5	5	72,5
600	0,6	6	87,0
700	0,7	7	101,5
800	0,8	8	116,0
900	0,9	9	130,5
1000	1	10	145,0
2000	2	20	290,1
3000	3	30	435,1
4000	4	40	580,2
5000	5	50	725,5
6000	6	60	870,2
7000	7	70	1015
8000	8	80	1160
9000	9	90	1305
10000	10	100	1450
20000	20	200	2901
30000	30	300	4351
40000	40	400	5802
50000	50	500	7252
60000	60	600	8702
70000	70	700	10153
80000	80	800	11603
90000	90	900	13053
100000	100	1000	14504
200000	200	2000	29008
300000	300	3000	43511

psi to metric (1 psi = 6,89 KPa)

Pounds per Square Inch (psi)	Kilo Pascal (KPa)	Mega Pascal (MPa)	Bar (Bar)
10	68,9	0,07	0,7
20	137,9	0,14	1,4
30	206,8	0,21	2,1
40	275,8	0,28	2,8
50	344,7	0,34	3,4
60	413,7	0,41	4,1
70	482,6	0,48	4,8
80	551,6	0,55	5,5
90	620,5	0,62	6,2
100	689	0,70	6,9
200	1379	1,4	13,8
300	2068	2,1	20,7
400	2758	2,8	27,6
500	3447	3,4	34,5
600	4137	4,1	41,4
700	4826	4,8	48,3
800	5516	5,5	55,2
900	6205	6,2	62,1
1000	6895	6,9	68,9
2000	13790	13,8	147,9
3000	20684	20,7	206,8
4000	27579	27,6	275,8
5000	34474	34,5	344,7
6000	41369	41,4	413,7
7000	48263	48,3	482,6
8000	55158	55,2	551,6
9000	62053	62,1	620,5
10000	68948	68,9	689
20000	137895	147,9	1379
30000	206843	206,8	2068
40000	275790	275,8	2758

CONVERSION TABLES FROM IMPERIAL SYSTEM TO METRIC SYSTEM

Inches	mm
1/64	.0156
1/32	.0312
3/64	.0468
1/16	.0625
5/64	.0781
3/32	.0937
7/64	.1093
1/8	.1250
9/64	.1406
5/32	.1562
11/64	.1718
3/16	.1875
13/64	.2031
7/32	.2187
15/64	.2343
1/4	.2500

Inches	mm
17/64	.2656
9/32	.2812
19/64	.2968
15/16	.3125
21/64	.3281
11/32	.3437
23/64	.3593
3/8	.3750
25/64	.3906
13/32	.4062
27/64	.4218
7/16	.4375
29/64	.4531
15/32	.4687
31/64	.4843
1/2	.5000

Inches	mm
33/64	.5156
17/32	.5312
35/64	.5468
9/16	.5625
37/64	.5781
19/32	.5937
39/64	.6093
5/8	.6250
41/64	.6406
21/32	.6562
43/64	.6718
11/16	.6875
45/64	.7031
23/32	.7187
47/64	.7343
3/4	.7500

Inches	mm
49/64	.7656
25/32	.7812
51/64	.7968
13/16	.8125
53/64	.8281
27/32	.8437
55/64	.8593
7/8	.8750
57/64	.8906
29/32	.9062
59/64	.9218
15/16	.9375
61/64	.9531
31/32	.9687
63/64	.9843
1	1000

// ADAPTERS GUIDELINES

ADAPTER SELECTION

Selection of an appropriate Dunlop Hiflex adapter for a given application depends on the fluid system operating parameters listed below and the tube material and wall thickness they require:

1. Type of fluid
2. Operating temperature range
3. Type of line - pressure, return or suction
4. Maximum flow rate through the line
5. Maximum operating / service pressure
6. Severity of service
7. Environment

Then, based on the tube selected and appropriate fluid system operating parameters, determine adapter type(s) and material(s) using the features comparison table below.

FEATURES COMPARISON OF TUBE FITTINGS				
Feature		ORFS	JIC 37°	BSP
Performance	Pressure capability*	Very High	Medium to High	Medium to High
	Seal Reliability	Excellent	Good	Very Good
		Elastomeric Seal	Metal to Metal Seal	Elastomeric Seal
		High tolerance to minor surface imperfections and damage. High tolerance to assembly variations.	Low tolerance to minor surface imperfections and damage. Low tolerance to assembly variations.	Low tolerance to minor surface imperfections and damage. Low tolerance to assembly variations.
Vibration Resistance in Rigid Systems	Excellent	Good	Very Good	
Tube Compatibility	Wall Thickness	All	Medium	Medium
	Critical Features	OD tolerance and hardness for flat tube, OD tolerance only for brazed tube	ID finish, wall thickness uniformity (concentricity) and hardness	OD tolerance and hardness
Assembly	Tube Preparation	Easy and quick (slower for sleeve brazing)	Easy and quick	Easy and quick (slower for welded nipple)
	Inspection	Easy and quick	Easy and quick	Critical, need experience
	Ease of Installation	Excellent, Minimum skill and training are necessary because of high tolerances to assembly variations	Good. Low tolerance to assembly variations. Requires skilled and trained personnel	
	Ease of Maintenance	Excellent, no tube entry	Very Good, Small tube entry	Good, Large tube entry
Temperature Capability Adapters without O-Ring	Steel	To be used only with O-ring	-65° F to 500° F	-65° F to 500° F
	Stainless Steel		-425° F to 1200° F	==
	Brass		-40° F to 400° F	==
Temperature Capability Adapters with O-Ring**	All Style of Adapter	-30 F to 250° F	-30 F to 250° F	-30 F to 250° F

* For details see Working Pressure Charts in the individual adapters section

** For details concerning O-ring see section "O-ring selection" and "Fluid Resistance Table"

JIC 37° ADAPTER (ISO 8434-2, SAE J514)

Main Features

SAE J514 and ISO 8434-2, and commonly called 37° JIC adapters.

37° JIC adapter performs extremely well in all high pressure applications.

The seal is made by connecting a 37° flared tube surface to a 37° flare male and tightening by means of a nut and a sleeve. The flared tube avoids welded connection, so high performances are guaranteed even in case of severe vibrations, mechanic/hydraulic shocks and multiple assembly/disassembly operations.

When tightened, sleeve provides tube and adapter self alignment and helps to reduce the vibrations on the tube during application.

An appropriate choice of sleeve gives the possibility of assembling adapters with both metric and inch-tubes.

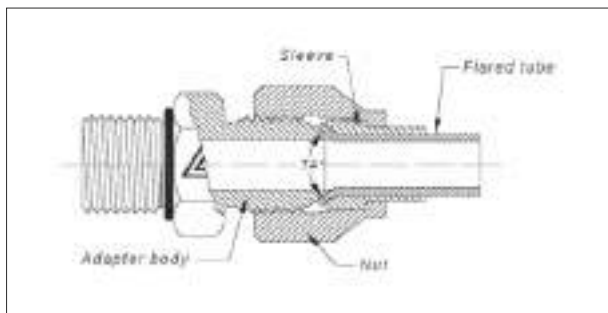

Flaring Operations

Perfect sealing is guaranteed with tubes having physical and mechanical characteristics obtained by cold-drawing and a ductility expressed as 21% of minimum elongation.

- Cut end of tube must be perpendicular to its axis . Note: cutting operation reduces the whole length of tube (almost 0,5±1mm for each end).
- Dimensions of the end of the tube shall allow the correct placing on the flaring machine.
- Flared surface must be inspected to avoid excessive roughness and defects such as cracks or exfoliation.
- Length of flared zone shall be enough to allow a sufficient sealing surface and avoid the blowing off of the tube, but not excessive to prevent the contact with thread of the nut.
- A well followed flaring procedure assures no leakage even after frequent assembling and disassembling operations.

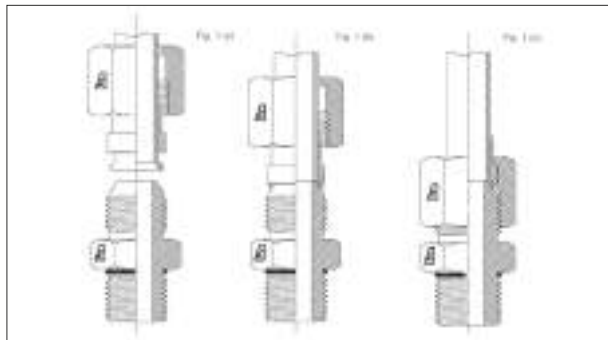

ORFS ADAPTER (ISO 8434-3, SAE J1453)

Main Features

Adapters are designed and manufactured according to standard SAE J1453 and commonly called ORFS adapters.

O-Ring Face Seal adapters performs extremely well in all high pressure applications where elastomeric seals are needed to overcome leakage and leak resistance is crucial.

A seal is made when the O-Ring in the male contacts the 180° flat face of the tube. The male connector has a straight thread and a machined flat face. The seal takes place by compressing the O-Ring onto the flat face of the female.

ORFS system is composed by:

- Nut.
- Sleeve for flat tube and a shouldered sleeve for brazing. An appropriate choice of sleeve gives the possibility of assembling adapters with both metric and inch-tubes.
- Various kind and size of adapter body.
- O-Ring material is NBR, Shore "A": 90, suitable for a temperature range of: - 30°/+130° C (-22/+266° F).

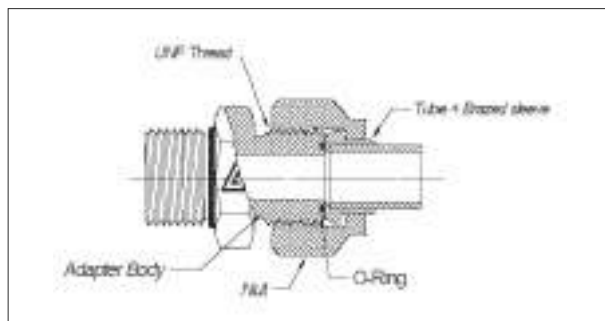

Flaring Tube Operations

Perfect sealing is guaranteed with tubes having physical and mechanical characteristics obtained by cold-drawing and a ductility expressed as 21% of minimum elongation.

- Cut end of tube must be perpendicular to its axis.
- Cutting operation reduces the whole length of tube.
- Dimensions of the end of the tube shall allow the correct placing on the flaring machine.
- Flared surface must be inspected to avoid excessive roughness and defects such as cracks or exfoliation.
- Brazing sleeve guarantees the same performances as the flared tube, and shall be used in the following cases:
- Tube is not in accordance with the above mechanical characteristics.
- The straight part of the tube is not of a sufficient length (see quote L2 and values listed in table of figure O-3).
- Tube thickness is lower than values listed in table (O-1).
- For cutting length consider shoulder of the sleeve (quote L1 of table O-1).

A well followed flaring procedure assures no leakage even after frequent assembling and disassembling operations.

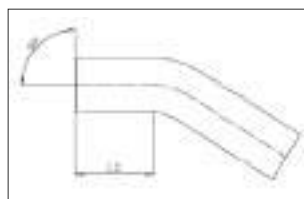

Hose mm	L2 Min mm
Ø 6 - Ø 12	73
Ø 14 - Ø 18	100
Ø 20 - Ø 22	120
Ø 25 - Ø 42	130

Only a few simple operations are required for assembling ORFS tube/adaptor.

Sleeve and Tube Flared:

- 1a) Place nut and sleeve on the tube with the appropriate orientation.
- 2a) Flare the tube (see procedure)
- 3a) Place the tube near seal surface of the adapter and screw by hand.
- 4a) Lock the adapter and tighten with a torque wrench

Brazed sleeve

- 1b) Cut the tube considering quote L1 of the sleeve (See Figure O-5);
- 2b) Clean and degrease accurately the end of the tube and the sleeve;
- 3b) Put the brazing ring into the sleeve
- 4b) Apply flux at the end of the tube and in the sleeve, then assemble the sleeve on the tube;
- 5b) Start brazing and be aware of not overheating flux material;
- 6b) Clean the connecting part and verify the good quality of weld around the external diameter of the hose;
- 7b) Complete the assembly procedure as described in points 3a) and 4a). See the correct installation torque in the attached table (O-2).

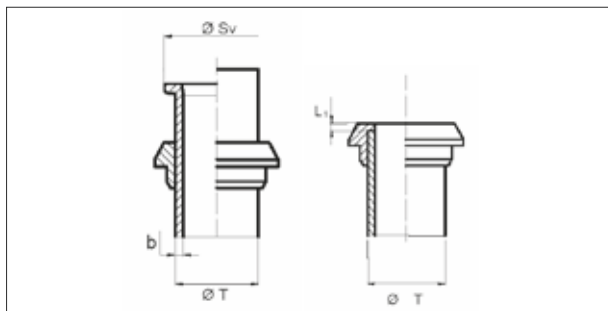

Hose		SV	
mm	In	mm	In
6	1/4	12,0	12,7
8	5/16	14,7	15,7
10	3/8	14,7	15,7
12	1/2	17,9	18,9
15		22,1	23,4
16	5/8	22,1	23,4
18		26,3	27,8
20	3/4	26,3	27,8
22		32,4	34,2
25	1	32,4	34,2
28		39,0	40,5
30		39,0	40,5
32	1.1/4	39,0	40,5
35		46,0	48,5
38	1.1/2	46,0	48,5

BSP ADAPTER (ISO 8434-6, BS 5200)

Main Features

Adapters are designed and manufactured according to standard BS 5200, ISO 8434-6 and ISO 228-1 and they are commonly called BSP adapters (British Standard Pipe) BSP adapter is widely employed, it performs extremely well in all high pressure applications with oil and gas. The seal is made by connecting a 60° coned seat to the 60° male surface and tightening the nut assembly. The O-Ring placed in the tube groove improves the sealing. There are not welded part in the locking area and performances are good even after multiple assembly and disassembly operations, severe vibrations and mechanic/hydraulic shocks.

Assembling Procedure

Only a few simple operations are required for assembling BSP tube/adaptor:

1. Carefully align tube and adapter. Otherwise sealing is not guaranteed.
2. Lubricate accurately sealing surfaces with mineral oil or suitable lubricant.
3. Place the tube near seal surface of the adapter and tight by hand.
4. Lock the adapter and tighten with a torque wrench. See the correct installation torque in the attached table B-1.

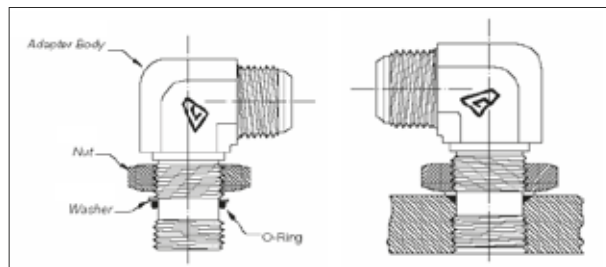

Assembly Instruction For Adjustable Adapter Thread: SAE, UNF, BSPP, Metric

Lubricate the O-Ring with mineral oil. Back off locknut as for as possible.

Make sure that washer is pushed-up as much as possible. Screw by hand the adapter into the port until the ORing enter the port.

To align adaptor orientation to tube end or hose assembly, unscrew the adaptor by the required amount, but not more than one full turn.

Hold the adapter in desired position by mean of a wrench and tighten locknut to the suggested torque value by means of a dynamometric wrench.

METRIC PORT - ISO 6149 - SAE 2244-1

Metric Thread	D2 ²⁾ min	D3 ³⁾ min	D5 +0,10	D6 +0,50	L1 +0,40	L2 min	L3 max	L4	Z° ±1°	Assembly Torque +10%
D1	mm	mm	mm	mm	mm	mm	mm	mm		Nm
M8x1	17	14	9,1	14	1,6	11,5	1	10	12°	10
M10x1	20	16	11,1	16	1,6	11,5	1	10	12°	20
M12x1,5	23	19	13,8	19	2,4	14	1,5	11,5	15°	35
M14x1,51)	25	21	15,8	21	2,4	14	1,5	11,5	15°	45
M16x1,5	28	24	17,8	24	2,4	15,5	1,5	13	15°	55
M18x1,5	30	28	19,8	26	2,4	17	2	14,5	15°	70
M22x1,5	34	29	23,8	29	2,4	18	2	15,5	15°	100
M27x3	40	34	29,4	34	3,1	22	2	19	15°	170
M33x2	49	43	35,4	43	3,1	22	2,5	19	15°	310
M42x2	60	52	44,4	52	3,1	22,5	2,5	19,5	15°	330
M48x2	66	57	50,4	57	3,1	25	2,5	22	15°	420
M60x2	76	67	52,4	67	3,1	27,5	2,5	24,5	15°	500

- 1) Preferred for diagnostic port application
- 2) Spotface diameter with identification ridge
- 3) Spotface diameter without identification ridge

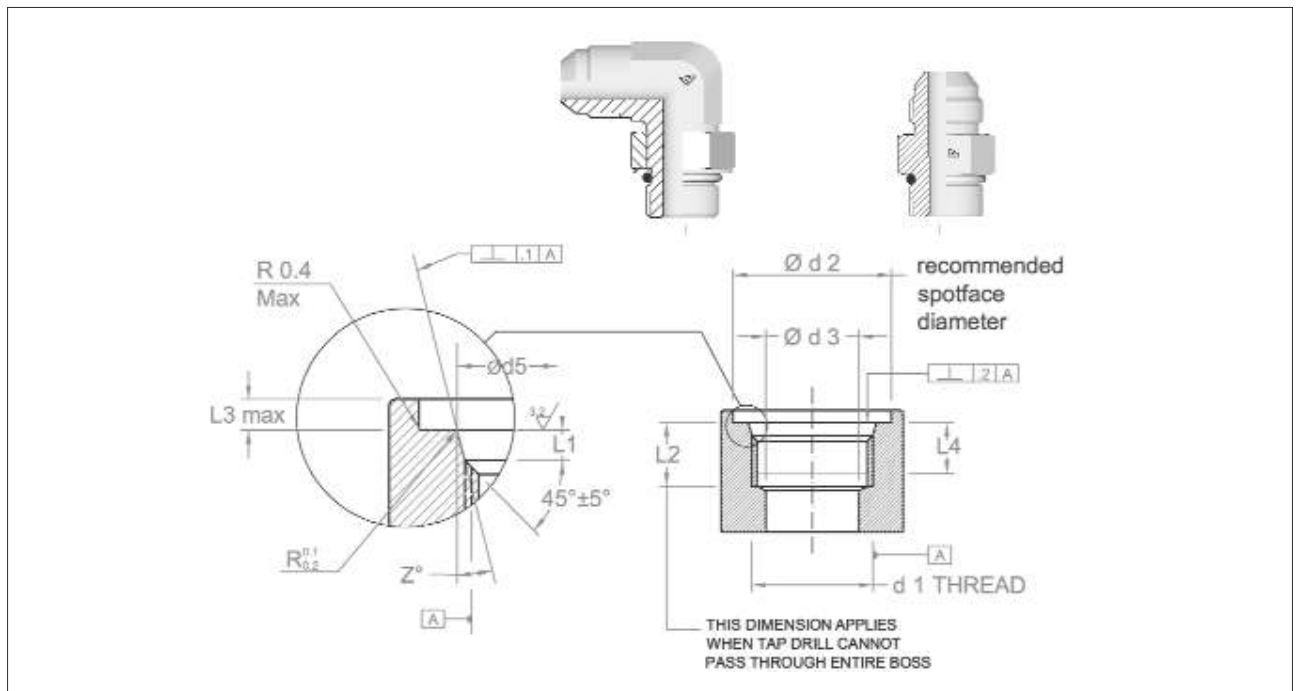

SAE UNF PORT - SAE J1926-1 - ISO 11926

ANSI B1.1	D2	D3 min	D3 +0,13	L1 +0,40	L2 min	L3 max	L4 min	Z° ±1°	Assembly Torque +10%
D1	mm	mm	mm	mm	mm	mm	mm		Nm
7/16"-20	21	4,4	12,4	2,4	14	1,6	11,5	12°	20
1/2"-20	23	6	14	2,4	14	1,6	11,5	12°	25
9/16"-18	25	7,5	15,6	2,5	15,5	1,6	12,7	12°	35
3/4"-16	30	10	20,6	2,5	17,5	2,4	14,3	15°	70
7/8"-14	34	12,5	23,9	3,3	20	2,4	16,7	15°	100
1" 1/16-12	41	16	29,2	3,3	23	2,4	19	15°	170

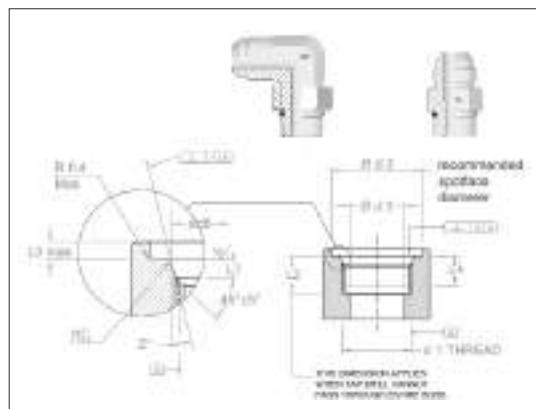

BSPP PORT - ISO 9974 - DIN 3852-1

ANSI B1.1 Thread	D3 +0.20	D4	L1 max	L2 min	Assembly Torque +10%
D1	mm	mm	mm	mm	Nm
1/8"-28	9,8	15	1	8	20
1/4"-19	13,2	20	1,5	12	50
3/8"-19	16,7	23	2	12	80
1/2"-14	21	28	2,5	14	100
3/4"-14	26,5	33	2,5	16	200
1"-11	33,3	41	2,5	18	380
1" 1/4-11	42	51	2,5	20	500
1" 1/2-11	47,9	56	2,5	22	600

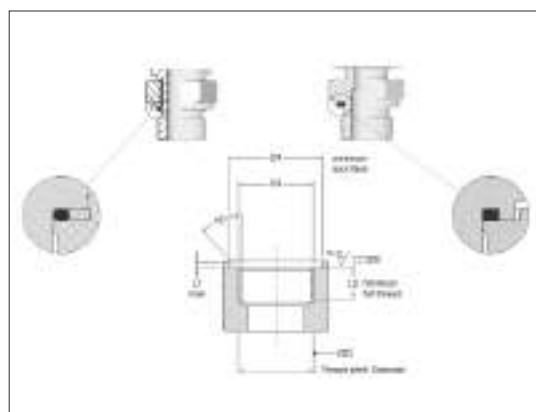

METRIC PORT - ISO 9974 - DIN 3852-1

Metric Thread	D3 +0.20	D4 min	L1 max	L2 min	Assembly Torque +10%
D1	mm	mm	mm	mm	Nm
M12x1,5	12	18	1,5	12	35
M14x1,5	14	20	1,5	12	45
M16x1,5	16	23	1,5	12	55
M18x1,5	18	25	2	12	68
M20x1,5	20	27	2	14	80
M22x1,5	22	28	2,5	14	98
M27x2	27	33	2,5	16	180
M33x2	33	41	2,5	18	310
M42x2	42	51	2,5	20	330
M48x2	48	56	2,5	22	400

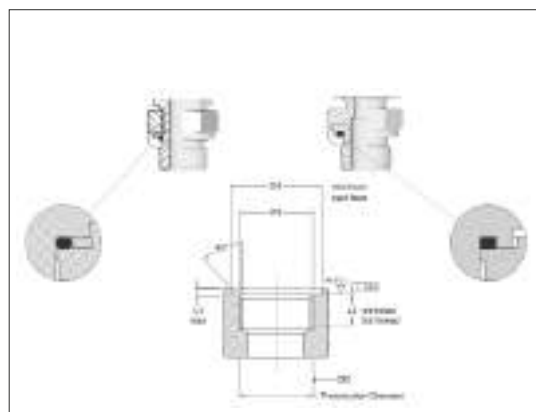

- ▲ HYDRAULICS
- ▲ HOSES
- ▲ VALVES
- ▲ PNEUMATICS
- ▲ FILTRATION
- ▲ MEASUREMENT AND CONTROL



APH Techniek BV
`s-Gravenzandseweg 16
2291 PE Wateringen
The Netherlands

P / +31 (0)174 219 200
F / +31 (0)174 219 209
E / info@aphtechnik.nl

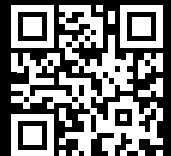

www.aphtechnik.nl

HYDRAULIC AND PNEUMATIC SOLUTIONS